

SHOPAIR CHAIN HOIST - ACH-100

APPROX WEIGHT: 111.95 lbs.
DOES NOT INCLUDE WEIGHT OF POWER OR PACKAGING!!!

*** ANY ADDITIONS, DELETIONS, OR OMISSIONS MUST BE CORRECTED ON THIS DRAWING AS THIS DRAWING WILL BE CONSIDERED ALL INCLUSIVE ***

ALL GRAPHICS PROVIDED ARE FOR REFERENCE ONLY. IF CERTAIN DIMENSIONS ARE CRITICAL PLEASE VERIFY THOSE DIMENSIONS WITH YOUR SALESPERSON

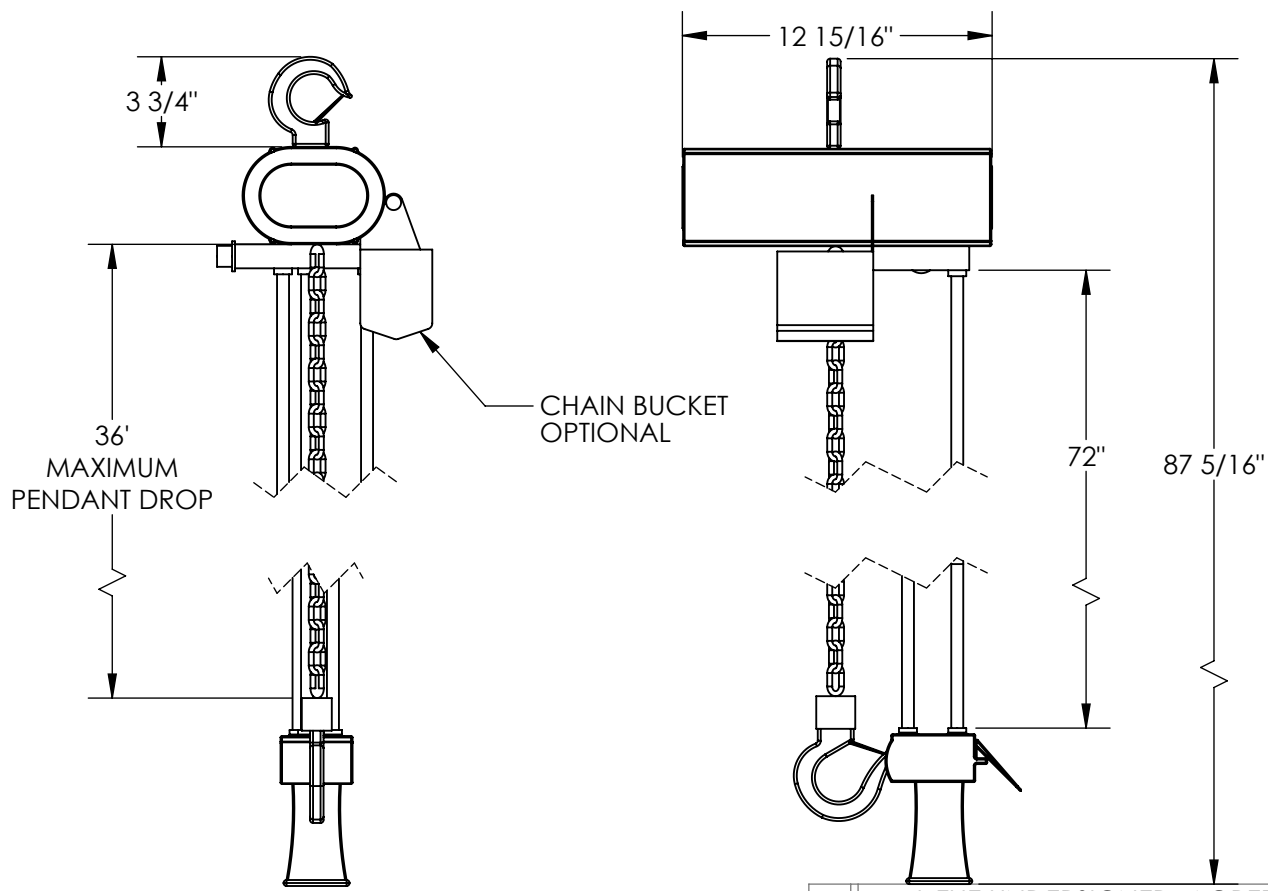
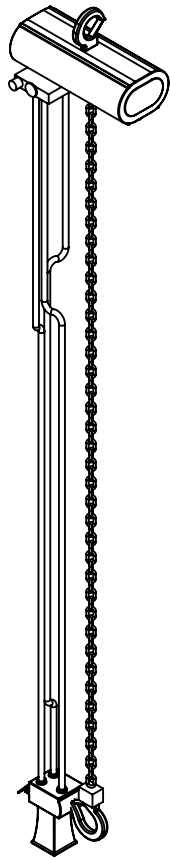

STANDARD FEATURES

MODEL NUMBER IS ACH-100
OVERALL LENGTH IS 72"
MAXIMUM PENDANT DROP 36"
VARIABLE FLOW, TWO LEVER
PENDANT FOR PRECISE
LOAD SPOTTING
MAX CAPACITY IS 1000 LBS.

SPECIAL FEATURES

NONE

PLEASE CIRCLE SPECIFICATIONS:

| | | | |
|--------------------------------------|--------|-----------|-----------|
| POWER | AC | *DC (12V) | * AIR/OIL |
| MOTOR VOLTAGE | 115 | 208 | 230 460 |
| DEDICATED CIRCUIT REQUIRED | | | |
| MOTOR PHASE | SINGLE | THREE | |
| CONTROL | HAND | * FOOT | |
| ~ ALL BATTERY CHARGERS ARE 115V AC ~ | | | |
| * BATTERY CHRG. | REMOTE | ON-BOARD | |
| * CHRG. INDICATOR | YES | NO | |

* AVAILABLE AT ADDITIONAL COST

I, THE UNDERSIGNED, AGREE THAT THE PRODUCT AS REPRESENTED SATISFIES DESIGN AND DIMENSION REQUIREMENTS. I ALSO ACKNOWLEDGE MY DUTY TO CONFIRM PRODUCT AND INSTALLATION COMPLIANCE WITH ALL APPLICABLE FEDERAL, STATE AND LOCAL REGULATIONS AND STANDARDS.

ALL SPECIAL UNITS ARE NON-RETURNABLE

[] As drawn [] As marked

Signed: _____ Date: _____

LEAD TIME WILL START UPON RECEIPT OF SIGNED APPROVAL DRAWING

| | | |
|----------------------|------------|------------|
| DISTRIBUTOR'S NAME: | | P.O.# |
| VESTIL MANUFACTURING | | X |
| DRAWN BY: CRM | | W.O.# |
| DATE: 03/01/2011 | | X |
| REFERENCE: X | SCALE: 1:8 | SALES: X |
| QUOTED LEAD TIME: X | QUOTE # X | FILE NAME: |
| | | 49-007-020 |