

# ELECTRIC HYDRAULIC SCISSOR LIFT TABLE - AHLT-4048-3-43

APPROX WEIGHT: 699.76 lbs.  
DOES NOT INCLUDE WEIGHT OF POWER OR PACKAGING!!!

\*\*\* ANY ADDITIONS, DELETIONS, OR OMISSIONS MUST BE CORRECTED ON THIS DRAWING AS THIS DRAWING WILL BE CONSIDERED ALL INCLUSIVE \*\*\*

ALL GRAPHICS PROVIDED ARE FOR REFERENCE ONLY. IF CERTAIN DIMENSIONS ARE CRITICAL PLEASE VERIFY THOSE DIMENSIONS WITH YOUR SALESPERSON

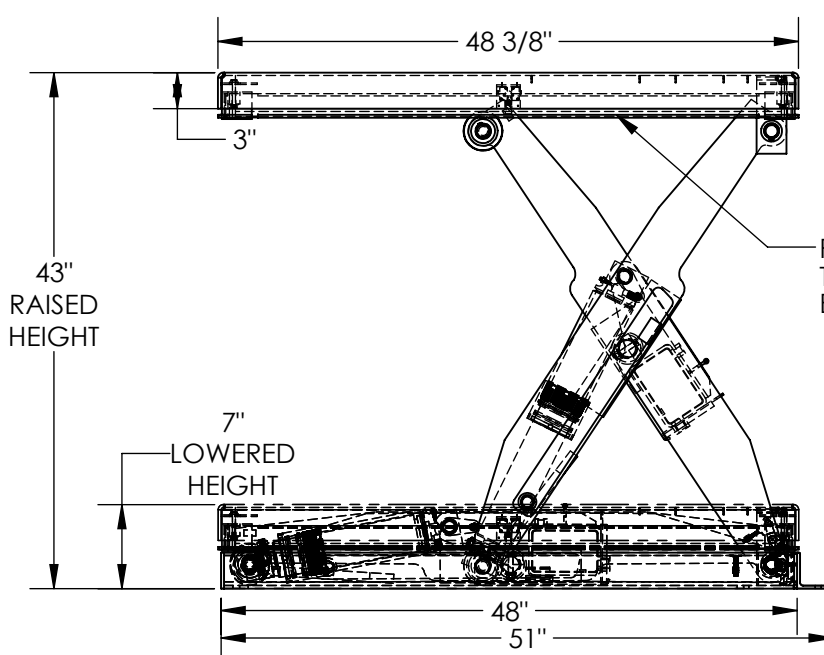

PNEUMATIC TOEGUARDS (STOPS TABLE FROM LOWERING IF BUMPED) MEETS OSHA 1910.212

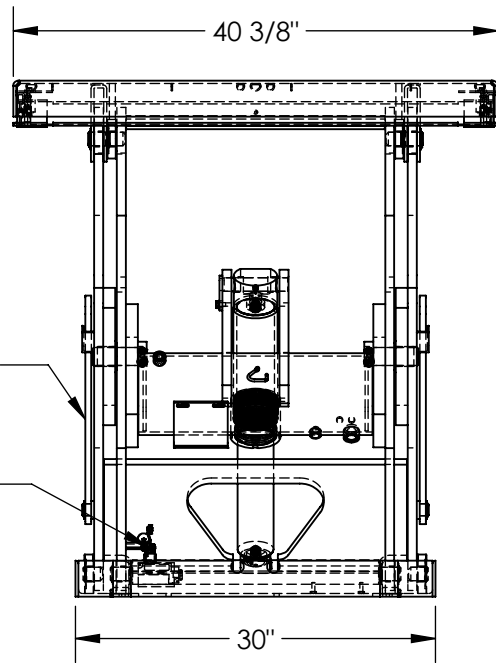

- ROTARY AIR / OIL POWER UNITS HAVE AN APPROX 1/2 GPM AT A MAXIMUM 3000 PSI
- AIR REQUIREMENTS 80 CFM @ 80 PSI WITH 3/4" DIAMETER AIR SUPPLY HOSE AT 50 FEET MAX
- NOISE LEVEL APPROX. 100 dB @ 6 FEET
- NOISE LEVEL APPROX. 90 dB @ 10 FEET
- \* ALL ROTARY AIR / OIL POWER UNITS REQUIRE A FILTER / REGULATOR / LUBRICATOR (FRL)
- \* FRLs ARE SOLD SEPARATELY
- \* WARRANTY WILL BE VOIDED IF FRL IS NOT USED
- \*HAND CONTROLS ON 8FT LONG HOSE

## STANDARD FEATURES

- MODEL NUMBER IS AHLT-4048-3-43
- PLATFORM WIDTH IS 40 3/8"
- PLATFORM LENGTH IS 48 3/8"
- OVERALL LENGTH IS 51"
- PLATFORM RAISED HEIGHT IS 43"
- PLATFORM LOWERED HEIGHT IS 7"
- TABLE CAPACITY (EVENLY DISTRIBUTED) LOAD IS 3,000 LBS
- CONTROLS HAND PENDANT ON 8' CORD
- SAFETY MAINTENANCE PROPS, DISPLACEMENT STYLE CYLINDERS INSTALLED ROD DOWN EMERGENCY SAFETY STOP HYDRAULIC FUSES IN ALL CYLINDER UNITS
- INTERNAL POWER UNIT
- DURABLE LIQUID PAINT BLUE FINISH

## SPECIAL FEATURES

NONE

## PLEASE CIRCLE SPECIFICATIONS:

POWER	<del>AC</del>	<del>DC (12V)</del>	<del>AIR/OIL</del>
MOTOR VOLTAGE	<u>115</u>	<del>208</del>	<del>230</del> <del>460</del>
<del>DEDICATED CIRCUIT REQUIRED 60Hz</del>			
MOTOR PHASE	<del>SINGLE</del>	<del>THREE</del>	
CONTROL	<del>HAND</del>	<del>FOOT</del>	

FOR INTERNAL USE ONLY PROJECT SIGN OFF	
SALES	
ENG.	
FAB.	
POWER	

DECK TOLERANCE ± 1/2"  
TABLE HEIGHT TOLERANCE ± 1/2"  
DECK FLATNESS ± 1/4"

DIMENSION TOLERANCE ± 1/4"

I, THE UNDERSIGNED, AGREE THAT THE PRODUCT AS REPRESENTED SATISFIES DESIGN AND DIMENSION REQUIREMENTS. I ALSO ACKNOWLEDGE MY DUTY TO CONFIRM PRODUCT AND INSTALLATION COMPLIANCE WITH ALL APPLICABLE FEDERAL, STATE AND LOCAL REGULATIONS AND STANDARDS.

**ANY MODIFIED UNITS ARE NON-RETURNABLE**

[ ] As drawn      [ ] As marked

Signed: \_\_\_\_\_ Date: \_\_\_\_\_

Printed Name: \_\_\_\_\_

**LEAD TIME WILL START UPON RECEIPT OF SIGNED APPROVAL DRAWING**

DISTRIBUTOR'S NAME:		P.O.#
VESTIL MANUFACTURING		X
DRAWN BY: CRA		W.O.#
DATE: 03/08/2019		X
REFERENCE: X	SCALE: 1:16	SALES: X
QUOTED LEAD TIME: X	QUOTE # X	FILE NAME:
		24-007-051-102