

ELECTRIC HYDRAULIC SCISSOR LIFT TABLE - AHLT-4872-3-43

APPROX WEIGHT: 844.24 lbs.
 DOES NOT INCLUDE WEIGHT OF POWER OR PACKAGING!!!

*** ANY ADDITIONS, DELETIONS, OR OMISSIONS MUST BE CORRECTED ON THIS DRAWING AS THIS DRAWING WILL BE CONSIDERED ALL INCLUSIVE ***

ALL GRAPHICS PROVIDED ARE FOR REFERENCE ONLY. IF CERTAIN DIMENSIONS ARE CRITICAL PLEASE VERIFY THOSE DIMENSIONS WITH YOUR SALESPERSON

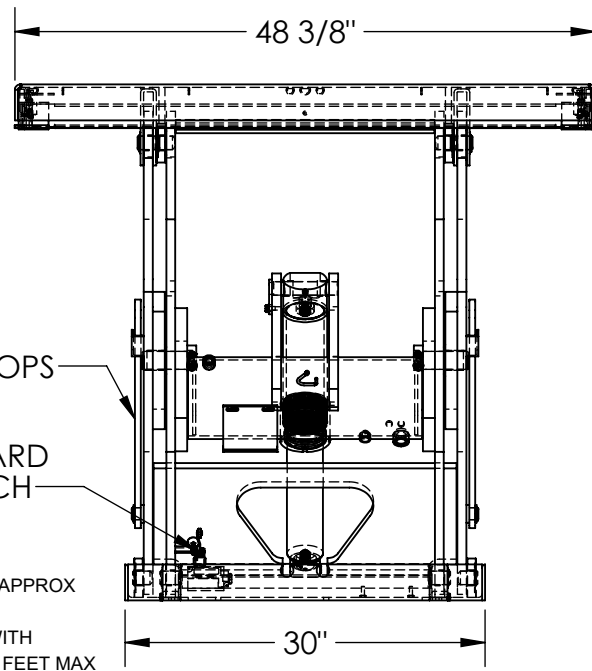
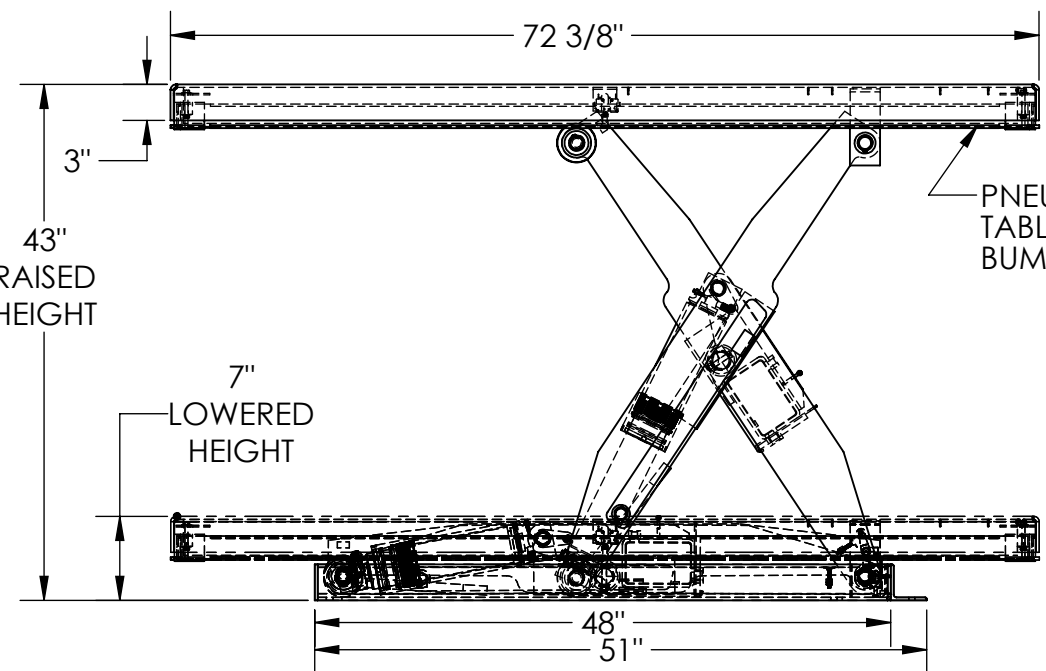

PNEUMATIC TOEGUARDS (STOPS TABLE FROM LOWERING IF BUMPED) MEETS OSHA 1910.212

MAINTENANCE PROPS
 ADJUSTABLE UPWARD TRAVEL LIMIT SWITCH

- ROTARY AIR / OIL POWER UNITS HAVE AN APPROX 1/2 GPM AT A MAXIMUM 3000 PSI
- AIR REQUIREMENTS 80 CFM @ 80 PSI WITH 3/4" DIAMETER AIR SUPPLY HOSE AT 50 FEET MAX
- NOISE LEVEL APPROX. 100 dB @ 6 FEET
- NOISE LEVEL APPROX. 90 dB @ 10 FEET
- * ALL ROTARY AIR / OIL POWER UNITS REQUIRE A FILTER / REGULATOR / LUBRICATOR (FRL)
- * FRLs ARE SOLD SEPARATELY
- * WARRANTY WILL BE VOIDED IF FRL IS NOT USED
- * HAND CONTROLS ON 8FT LONG HOSE

DIMENSION TOLERANCE ± 1/4"

STANDARD FEATURES

- MODEL NUMBER IS AHLT-4872-3-43
- PLATFORM WIDTH IS 48 3/8"
- PLATFORM LENGTH IS 72 3/8"
- OVERALL LENGTH IS 72 3/8"
- PLATFORM RAISED HEIGHT IS 43"
- PLATFORM LOWERED HEIGHT IS 7"
- TABLE CAPACITY (EVENLY DISTRIBUTED) LOAD IS 3,000 LBS
- CONTROLS HAND PENDANT ON 8' CORD
- SAFETY MAINTENANCE PROPS, DISPLACEMENT STYLE CYLINDERS INSTALLED ROD DOWN EMERGENCY SAFETY STOP HYDRAULIC FUSES IN ALL CYLINDER UNITS
- INTERNAL POWER UNIT
- DURABLE LIQUID PAINT BLUE FINISH

SPECIAL FEATURES

NONE

PLEASE CIRCLE SPECIFICATIONS:

POWER	AC	DC (12V)	AIR/OIL
MOTOR VOLTAGE	115	208	230 460
DEDICATED CIRCUIT REQUIRED 60Hz			
MOTOR PHASE	SINGLE	THREE	
CONTROL	HAND	FOOT	

FOR INTERNAL USE ONLY PROJECT SIGN OFF	
SALES	
ENG.	
FAB.	
POWER	

DECK TOLERANCE ± 1/2"
 TABLE HEIGHT TOLERANCE ± 1/2"
 DECK FLATNESS ± 1/4"

I, THE UNDERSIGNED, AGREE THAT THE PRODUCT AS REPRESENTED SATISFIES DESIGN AND DIMENSION REQUIREMENTS. I ALSO ACKNOWLEDGE MY DUTY TO CONFIRM PRODUCT AND INSTALLATION COMPLIANCE WITH ALL APPLICABLE FEDERAL, STATE AND LOCAL REGULATIONS AND STANDARDS.

ANY MODIFIED UNITS ARE NON-RETURNABLE

[] As drawn [] As marked

Signed: _____ Date: _____

Printed Name: _____

LEAD TIME WILL START UPON RECEIPT OF SIGNED APPROVAL DRAWING

DISTRIBUTOR'S NAME:		P.O.#
VESTIL MANUFACTURING		X
DRAWN BY: CRA		W.O.#
DATE: 03/08/2019		X
REFERENCE: X	SCALE: 1:16	SALES: X
QUOTED LEAD TIME: X	QUOTE # X	FILE NAME:
		24-007-051-104