

ALUMINUM LITE LOAD LIFT- ALLW-2420-4SFL

APPROX WEIGHT: 126.04 lbs.
DOES NOT INCLUDE WEIGHT OF POWER OR PACKAGING!!!

*** ANY ADDITIONS, DELETIONS, OR OMISSIONS MUST BE CORRECTED ON THIS DRAWING AS THIS DRAWING WILL BE CONSIDERED ALL INCLUSIVE ***

ALL GRAPHICS PROVIDED ARE FOR REFERENCE ONLY. IF CERTAIN DIMENSIONS ARE CRITICAL PLEASE VERIFY THOSE DIMENSIONS WITH YOUR SALESPERSON

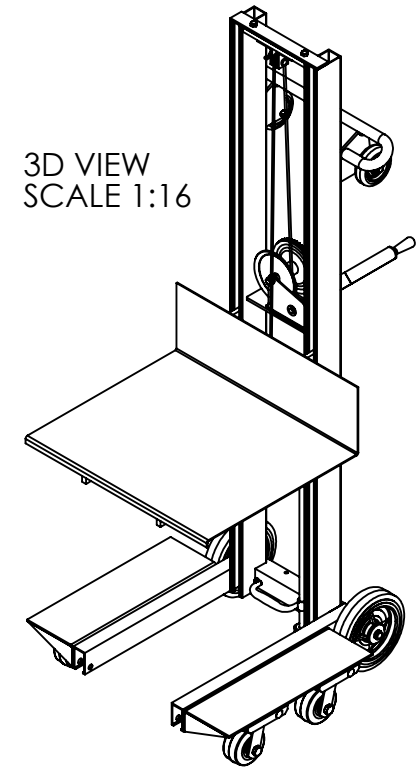
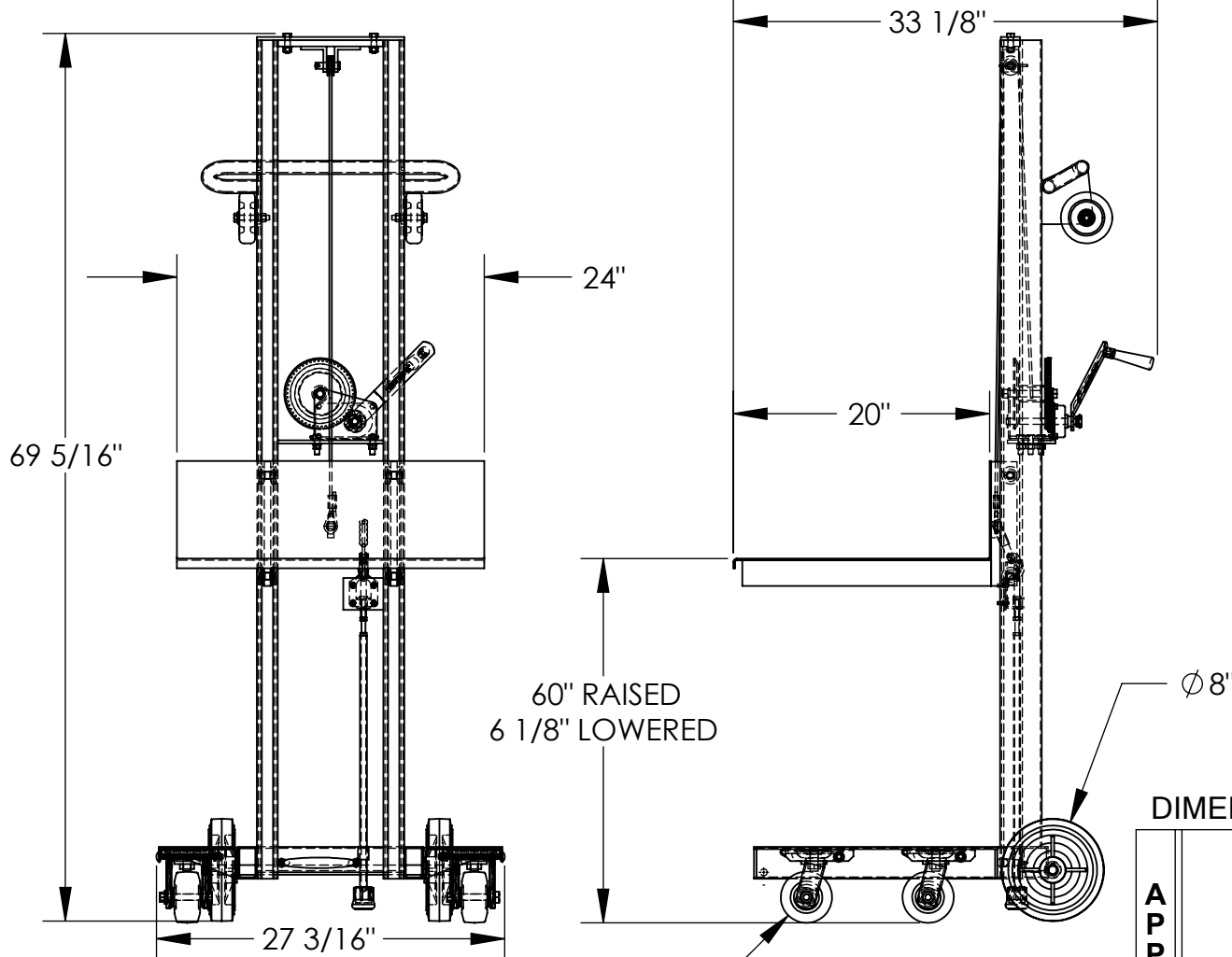

3D VIEW
SCALE 1:16

STANDARD FEATURES

- MODEL NUMBER: ALLW-2420-4SFL
- CAPACITY: 400 LBS.
- PLATFORM WIDTH: 24"
- PLATFORM LENGTH: 20"
- OVERALL WIDTH: 27 3/16"
- OVERALL LENGTH: 33 1/8"
- OVERALL HEIGHT: 69 5/16"
- RAISED HEIGHT: 60"
- LOWERED HEIGHT: 6 1/8"
- HAND WINCH OPERATION
- INCLUDES FLOOR LOCK
- ALUMINUM CONSTRUCTION

SPECIAL FEATURES

NONE

DIMENSION TOLERANCE ± 1/4"

APPROVAL

I, THE UNDERSIGNED, AGREE THAT THE PRODUCT AS REPRESENTED SATISFIES DESIGN AND DIMENSION REQUIREMENTS. I ALSO ACKNOWLEDGE MY DUTY TO CONFIRM PRODUCT AND INSTALLATION COMPLIANCE WITH ALL APPLICABLE FEDERAL, STATE AND LOCAL REGULATIONS AND STANDARDS.

ANY MODIFIED UNITS ARE NON-RETURNABLE

As drawn As marked

Signed: _____ Date: _____

Printed Name: _____

LEAD TIME WILL START UPON RECEIPT OF SIGNED APPROVAL DRAWING

FOR INTERNAL USE ONLY PROJECT SIGN OFF	
SALES	
ENG.	
FAB.	
POWER	

DISTRIBUTOR'S NAME:		P.O.#
VESTIL MANUFACTURING		X
DRAWN BY: KY		W.O.#
DATE: 8/30/05		X
REFERENCE: X	SCALE: 1:14	SALES: X
QUOTED LEAD TIME: X	QUOTE #	FILE NAME:
	X	42-007-019