

ALUMINUM WALK RAMP CART - AWR-R-CART-38

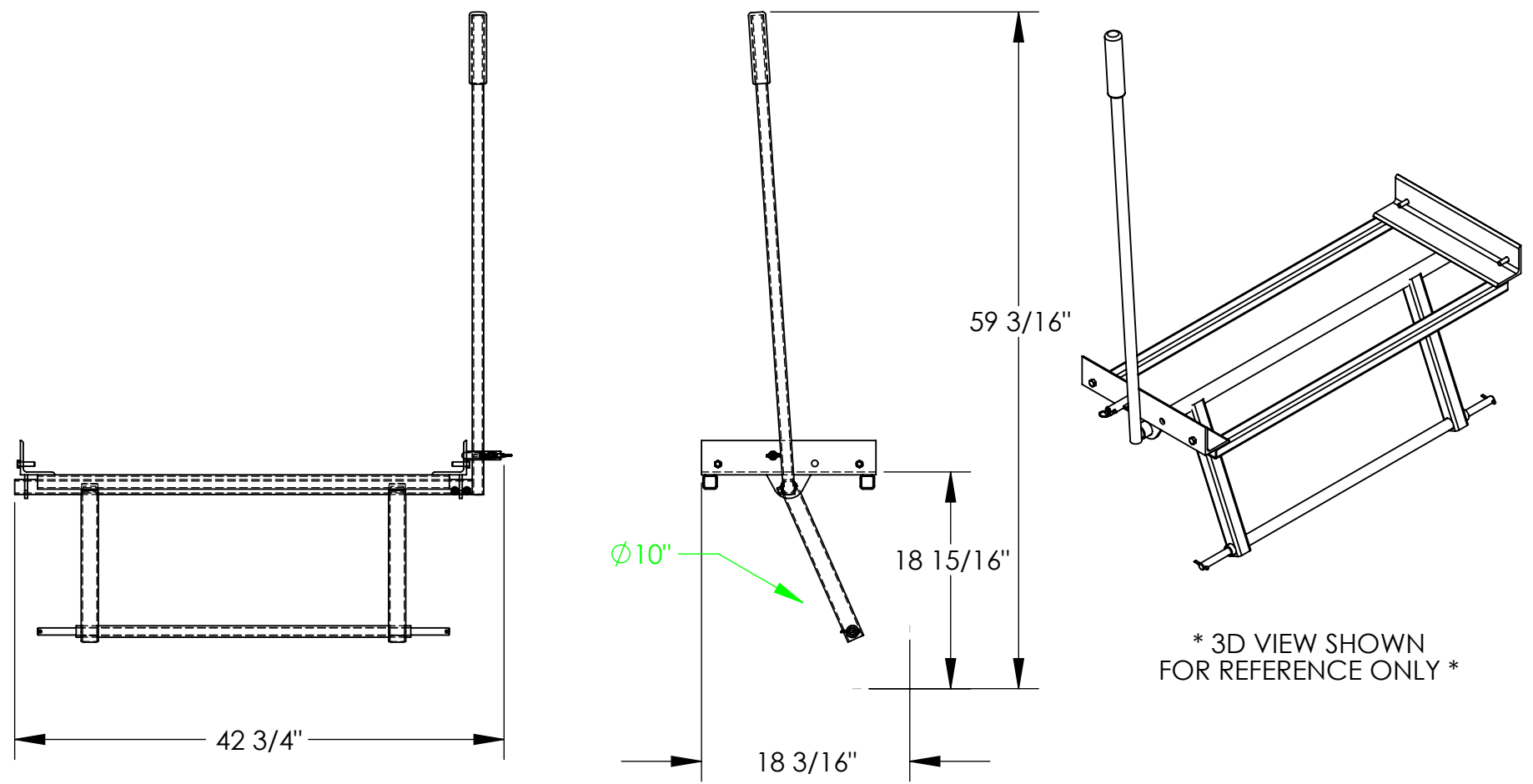

STANDARD FEATURES

MODEL NUMBER: AWR-R-CART-38
 OVERALL WIDTH: 42 3/4"
 OVERALL LENGTH: 18 3/16"
 OVERALL HEIGHT: 59 3/16"
 CASTER TYPE: 10" x 2 1/2" HARD RUBBER WHEELS

ALL SPECIAL UNITS ARE NON-RETURNABLE

APPROVAL

I, the undersigned, hereby approve this print.
 This includes my approval of design & dimensions

[] As drawn [] As marked

Signed: _____ Date: _____

LEAD TIME WILL START UPON RECEIPT OF SIGNED APPROVAL DRAWING

SPECIAL FEATURES
 NONE

DISTRIBUTOR'S NAME: VESTIL MANUFACTURING		P.O.# X
DRAWN BY: KY	DATE: 7/15/2005	W.O.# X
REFERENCE: X	SCALE: 1:14	SALES: X
	QUOTE # X	FILE NAME: 18-007-109