

ALUMINUM TRUCK DOCKBOARD - BTA-06005448

APPROX WEIGHT: 106.14 lbs.
DOES NOT INCLUDE WEIGHT OF POWER OR PACKAGING!!!

*** ANY ADDITIONS, DELETIONS, OR OMISSIONS MUST BE CORRECTED ON THIS DRAWING AS THIS DRAWING WILL BE CONSIDERED ALL INCLUSIVE ***

ALL GRAPHICS PROVIDED ARE FOR REFERENCE ONLY. IF CERTAIN DIMENSIONS ARE CRITICAL PLEASE VERIFY THOSE DIMENSIONS WITH YOUR SALESPERSON

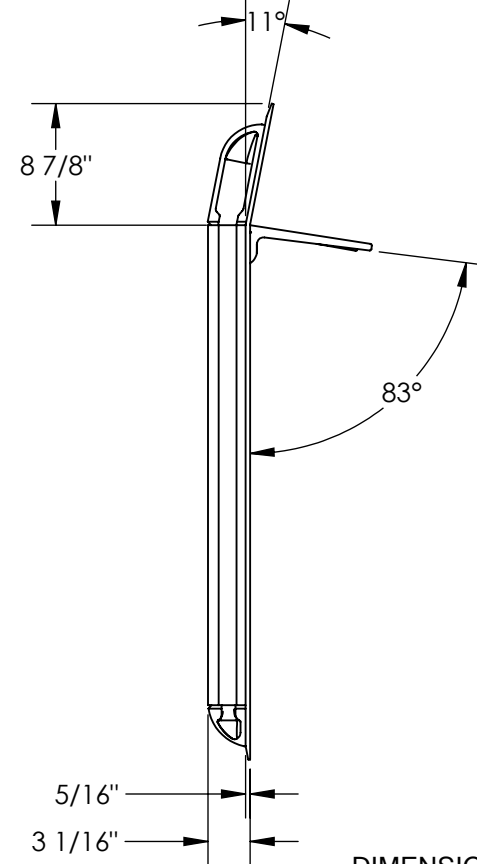
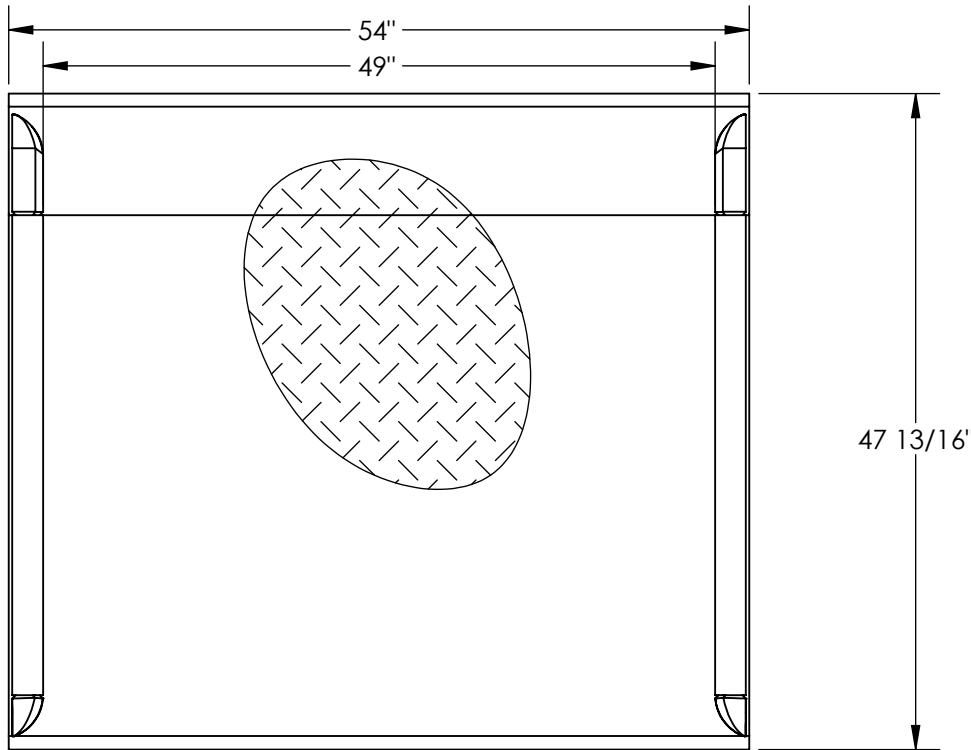

DIMENSION TOLERANCE ± 1/4"

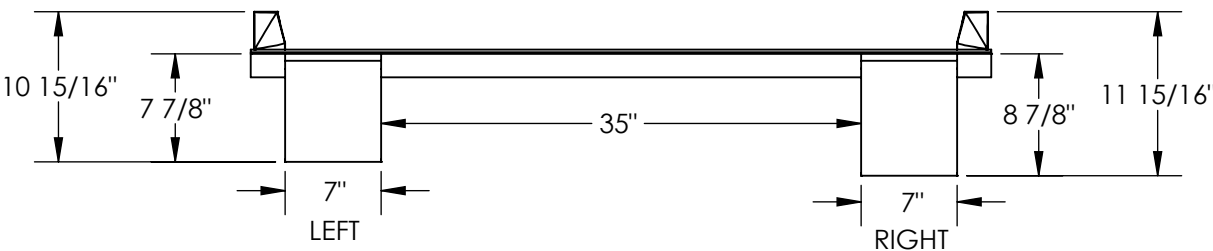

APPROVAL

I, THE UNDERSIGNED, AGREE THAT THE PRODUCT AS REPRESENTED SATISFIES DESIGN AND DIMENSION REQUIREMENTS. I ALSO ACKNOWLEDGE MY DUTY TO CONFIRM PRODUCT AND INSTALLATION COMPLIANCE WITH ALL APPLICABLE FEDERAL, STATE AND LOCAL REGULATIONS AND STANDARDS.

ANY MODIFIED UNITS ARE NON-RETURNABLE

[] As drawn [] As marked

Signed: _____ Date: _____

Printed Name: _____

LEAD TIME WILL START UPON RECEIPT OF SIGNED APPROVAL DRAWING

STANDARD FEATURES

- MODEL NUMBER IS BTA-06005448
- OVERALL WIDTH IS 54"
- USABLE WIDTH IS 49"
- OVERALL LENGTH IS 47 13/16"
- USABLE LENGTH IS 47 13/16"
- OVERALL HEIGHT IS 11 15/16"
- MAX CAPACITY IS 6,000 LBS
- HEIGHT DIFFERENCE IS 7"
- ALUMINUM CONSTRUCTION WITH WELDED ON ALUMINUM CURBS

SPECIAL FEATURES

NONE

LEGS: RIGHT LEG IS 8 7/8" LG, LEFT LEG IS 7 7/8" LG. LEGS ARE UNEVEN TO ALLOW FORK TRUCK TO LIFT THE DOCKBOARD

FOR INTERNAL USE ONLY PROJECT SIGN OFF	
SALES	
ENG.	
FAB.	
POWER	

DISTRIBUTOR'S NAME:		P.O.#
VESTIL MANUFACTURING		X
DRAWN BY: NHD		W.O.#
DATE: 11/16/17		X
REFERENCE: X	SCALE: 1:14	SALES: X
QUOTED LEAD TIME: X	QUOTE #	FILE NAME:
	X	11-007-147