

STEEL CHUTE HOPPERS - C-HOP-200

APPROX WEIGHT: 804.35 lbs.
DOES NOT INCLUDE WEIGHT OF POWER OR PACKAGING!!!

*** ANY ADDITIONS, DELETIONS, OR OMISSIONS MUST BE CORRECTED ON THIS DRAWING AS THIS DRAWING WILL BE CONSIDERED ALL INCLUSIVE ***

ALL GRAPHICS PROVIDED ARE FOR REFERENCE ONLY. IF CERTAIN DIMENSIONS ARE CRITICAL PLEASE VERIFY THOSE DIMENSIONS WITH YOUR SALESPERSON

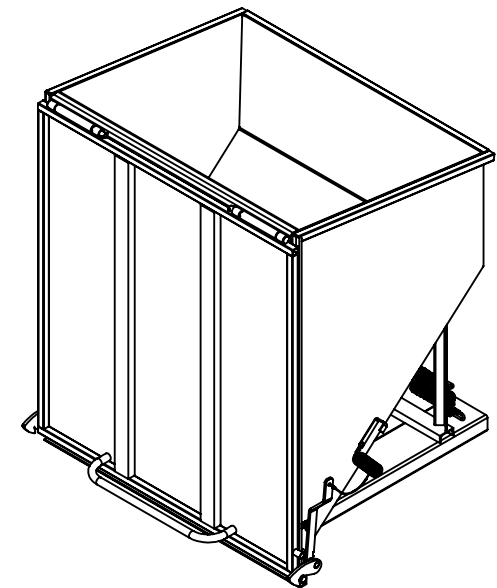
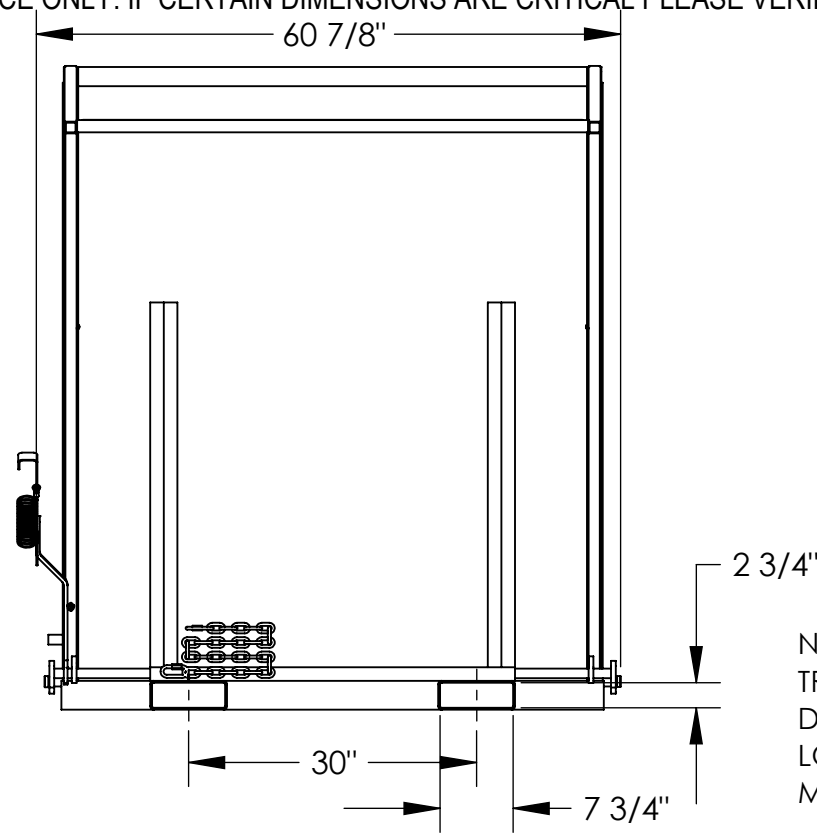
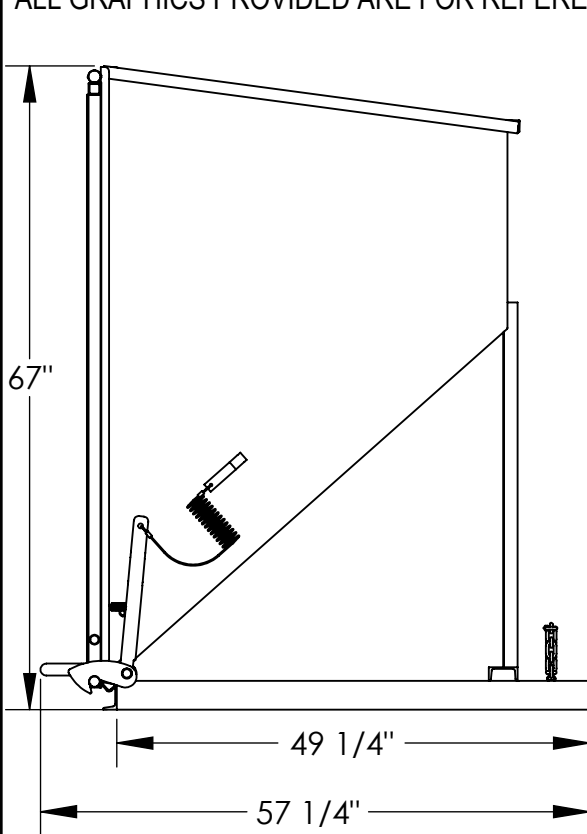

NEVER EXCEED LOAD CENTER RATING PER FORK TRUCK MANUFACTURER'S GUIDELINES. DO NOT USE THIS FORK TRUCK ATTACHMENT IF LOAD WILL EXCEED FORK TRUCK MANUFACTURER'S LOAD CENTER RATING.

APPROX. WEIGHT/ LOST LOAD=804.35 LBS.

FOR FORKS LONGER THAN 50"
EFFECTIVE THICKNESS= FORK LENGTH MINUS 49 1/4"
FOR FORK LENGTHS 48" OR SHORTER
MINIMIUM EFFECTIVE THICKNESS= LESS THAN 1"

STANDARD FEATURES

- MODEL NUMBER: C-HOP-200
- CAPACITY: 2,000 LBS.
- VOLUME: 2 CUBIC YARDS
- OVERALL WIDTH: 60 7/8"
- OVERALL LENGTH: 57 1/4"
- OVERALL HEIGHT: 67"
- FORK POCKETS: 7 3/4" W x 2 3/4" H
- USABLE ON 30" CENTERS
- FORK POCKETS LENGTH: 49 1/4"
- PULL CABLE RELEASE
- AUTOMATIC DOOR RETURN AND LATCH
- SAFETY CHAIN TO SECURE TO TRUCK
- DURABLE LIQUID PAINT BLUE FINISH

SPECIAL FEATURES

NONE

DIMENSION TOLERANCE ± 1/4"

APPROVAL

I, THE UNDERSIGNED, AGREE THAT THE PRODUCT AS REPRESENTED SATISFIES DESIGN AND DIMENSION REQUIREMENTS. I ALSO ACKNOWLEDGE MY DUTY TO CONFIRM PRODUCT AND INSTALLATION COMPLIANCE WITH ALL APPLICABLE FEDERAL, STATE AND LOCAL REGULATIONS AND STANDARDS.

ANY MODIFIED UNITS ARE NON-RETURNABLE

[] As drawn [] As marked

Signed: _____ Date: _____

Printed Name: _____

LEAD TIME WILL START UPON RECEIPT OF SIGNED APPROVAL DRAWING

FOR INTERNAL USE ONLY PROJECT SIGN OFF	
SALES	
ENG.	
FAB.	
POWER	

DISTRIBUTOR'S NAME:		P.O.#
VESTIL MANUFACTURING		X
W.O.#		X
DRAWN BY: WS	DATE: 3/31/2008	SALES: X
REFERENCE: X	SCALE: 1:20	FILE NAME:
QUOTED LEAD TIME: X	QUOTE # X	37-007-045