

# STEEL CHUTE HOPPER - C-HOP-300

APPROX WEIGHT: 1008.64 lbs.  
 DOES NOT INCLUDE WEIGHT OF POWER OR PACKAGING!!!

\*\*\* ANY ADDITIONS, DELETIONS, OR OMISSIONS MUST BE CORRECTED ON THIS DRAWING AS THIS DRAWING WILL BE CONSIDERED ALL INCLUSIVE \*\*\*  
 ALL GRAPHICS PROVIDED ARE FOR REFERENCE ONLY. IF CERTAIN DIMENSIONS ARE CRITICAL PLEASE VERIFY THOSE DIMENSIONS WITH YOUR SALESPERSON

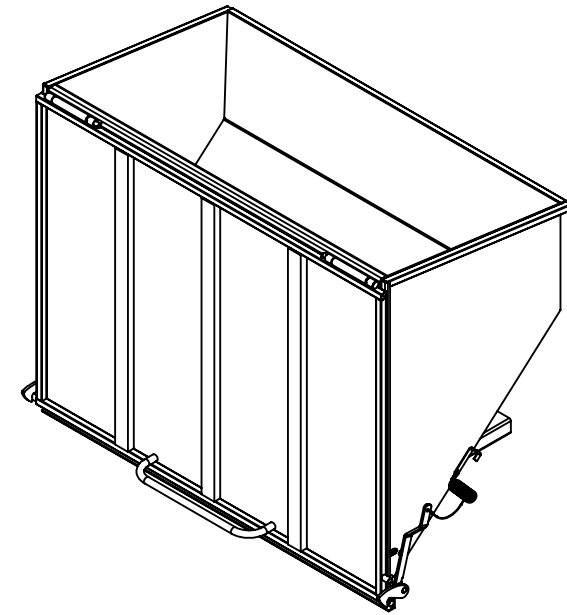
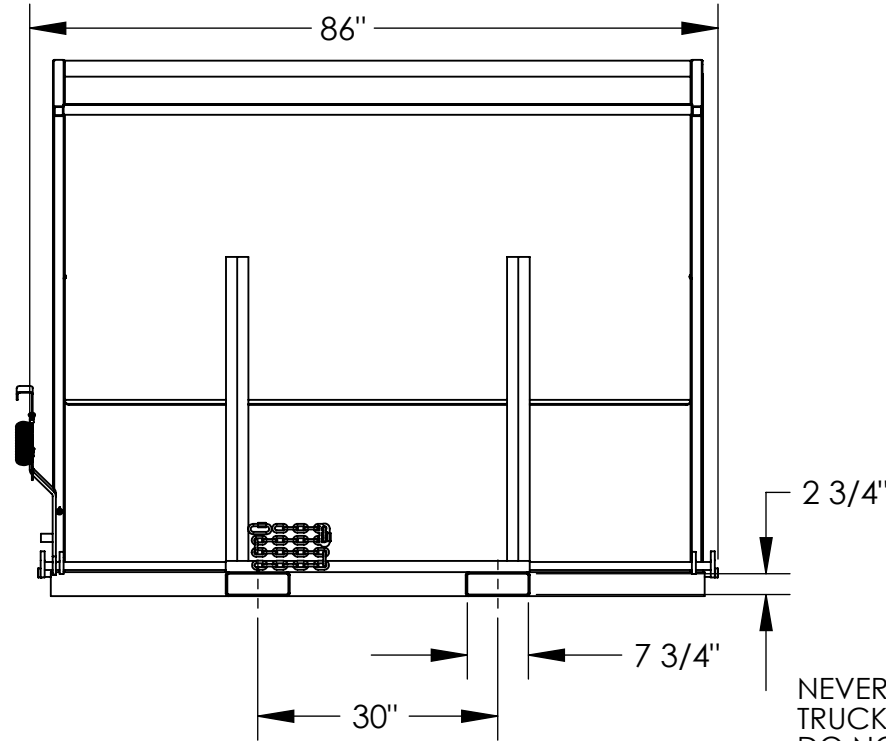
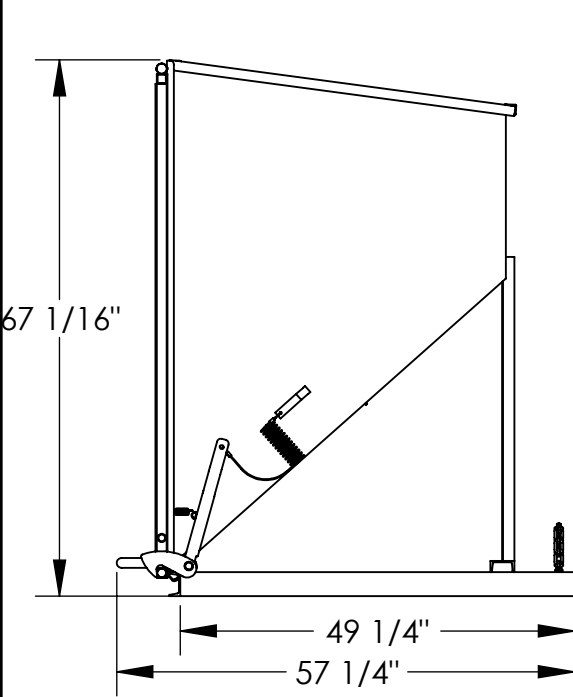

APPROX. WEIGHT/ LOST LOAD=1008.64 LBS.  
 FOR FORKS LONGER THAN 50"  
 EFFECTIVE THICKNESS= FORK LENGTH MINUS 49 1/4"  
 FOR FORK LENGTHS 48" OR SHORTER  
 MINIMIUN EFFECTIVE THICKNESS= LESS THAN 1"

NEVER EXCEED LOAD CENTER RATING PER FORK TRUCK MANUFACTURER'S GUIDELINES.  
 DO NOT USE THIS FORK TRUCK ATTACHMENT IF LOAD WILL EXCEED FORK TRUCK MANUFACTURER'S LOAD CENTER RATING.

**DIMENSION TOLERANCE ± 1/4"**

## STANDARD FEATURES

- MODEL NUMBER: C-HOP-300
- CAPACITY: 2,000 LBS.
- VOLUME: 3 CUBIC YARDS
- OVERALL WIDTH: 86"
- OVERALL LENGTH: 57 1/4"
- OVERALL HEIGHT: 67 1/16"
- FORK POCKETS ARE 7 3/4" W x 2 3/4" H USABLE ON 30" CENTERS AND ARE 49 1/4" LONG
- PULL CABLE RELEASE
- AUTOMATIC DOOR RETURN AND LATCH
- SAFETY CHAIN TO SECURE TO TRUCK
- DURABLE LIQUID PAINT BLUE FINISH

## SPECIAL FEATURES

NONE

APPROVAL	I, THE UNDERSIGNED, AGREE THAT THE PRODUCT AS REPRESENTED SATISFIES DESIGN AND DIMENSION REQUIREMENTS. I ALSO ACKNOWLEDGE MY DUTY TO CONFIRM PRODUCT AND INSTALLATION COMPLIANCE WITH ALL APPLICABLE FEDERAL, STATE AND LOCAL REGULATIONS AND STANDARDS.	
	<b>ANY MODIFIED UNITS ARE NON-RETURNABLE</b>	
	[ ] As drawn	[ ] As marked
	Signed: _____ Date: _____	
Printed Name: _____		
<b>LEAD TIME WILL START UPON RECEIPT OF SIGNED APPROVAL DRAWING</b>		

FOR INTERNAL USE ONLY PROJECT SIGN OFF	
SALES	
ENG.	
FAB.	
POWER	

DISTRIBUTOR'S NAME:		P.O.#
VESTIL MANUFACTURING		X
DRAWN BY: WS		W.O.#
DATE: 3/31/2008		X
REFERENCE: X	SCALE: 1:24	SALES: X
QUOTED LEAD TIME: X	QUOTE #	FILE NAME:
	X	37-007-046