

ELEVATED CAROUSEL BASE - CA-BASE-18-24

APPROX WEIGHT: 115.12 lbs.
 DOES NOT INCLUDE WEIGHT OF POWER OR PACKAGING!!!

*** ANY ADDITIONS, DELETIONS, OR OMISSIONS MUST BE CORRECTED ON THIS DRAWING AS THIS DRAWING WILL BE CONSIDERED ALL INCLUSIVE ***

ALL GRAPHICS PROVIDED ARE FOR REFERENCE ONLY. IF CERTAIN DIMENSIONS ARE CRITICAL PLEASE VERIFY THOSE DIMENSIONS WITH YOUR SALESPERSON

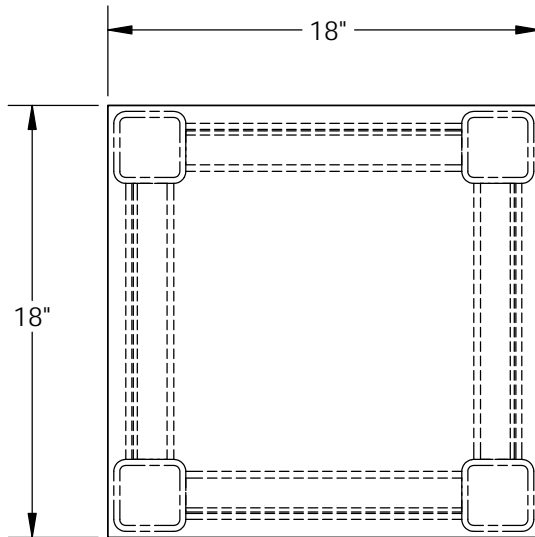

STANDARD FEATURES

MODEL NUMBER IS CA-BASE-18-24
 PLATFORM WIDTH: 18"
 PLATFORM LENGTH: 18"
 OVERALL HEIGHT: 24"
 STRADDLE I.D.: 11 1/2"
 UNIFORM CAPACITY: 2,000 LBS.
 STEEL CONSTRUCTION
 BLUE LIQUID PAINT FINISH

SPECIAL FEATURES

NONE

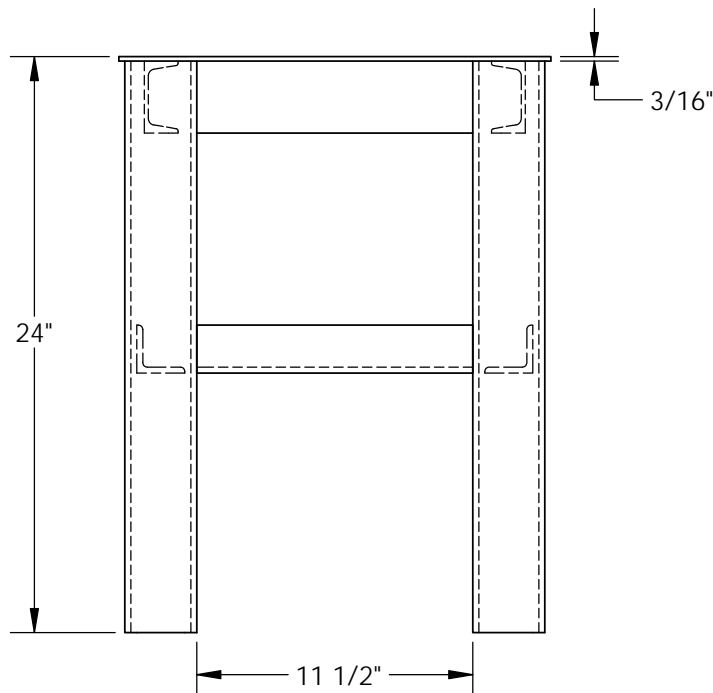

DIMENSION TOLERANCE $\pm 1/4"$

A P P R O V A L	I, THE UNDERSIGNED, AGREE THAT THE PRODUCT AS REPRESENTED SATISFIES DESIGN AND DIMENSION REQUIREMENTS. I ALSO ACKNOWLEDGE MY DUTY TO CONFIRM PRODUCT AND INSTALLATION COMPLIANCE WITH ALL APPLICABLE FEDERAL, STATE AND LOCAL REGULATIONS AND STANDARDS.	
	ANY MODIFIED UNITS ARE NON-RETURNABLE	
	[] As drawn [] As marked	
	Signed: _____	Date: _____
Printed Name: _____		
<i>LEAD TIME WILL START UPON RECEIPT OF SIGNED APPROVAL DRAWING</i>		

FOR INTERNAL USE ONLY PROJECT SIGN OFF	
SALES	
ENG.	
FAB.	
POWER	

DISTRIBUTOR'S NAME:		P.O.#
VESTIL MANUFACTURING		X
W.O.#		X
DRAWN BY: TJM	DATE: 02/16/15	SALES: X
REFERENCE: X	SCALE: 1:8	FILE NAME:
QUOTED LEAD TIME: X	QUOTE # X	20-007-158