

# DC POWERED HYDRAULIC SCISSOR LIFT CART- CARTD-1000-2033-DC

APPROX WEIGHT: 327.08 lbs.

DOES NOT INCLUDE WEIGHT OF POWER OR PACKAGING!!!

\*\*\* ANY ADDITIONS, DELETIONS, OR OMISSIONS MUST BE CORRECTED ON THIS DRAWING AS THIS DRAWING WILL BE CONSIDERED ALL INCLUSIVE \*\*\*

ALL GRAPHICS PROVIDED ARE FOR REFERENCE ONLY. IF CERTAIN DIMENSIONS ARE CRITICAL PLEASE VERIFY THOSE DIMENSIONS WITH YOUR SALESPERSON

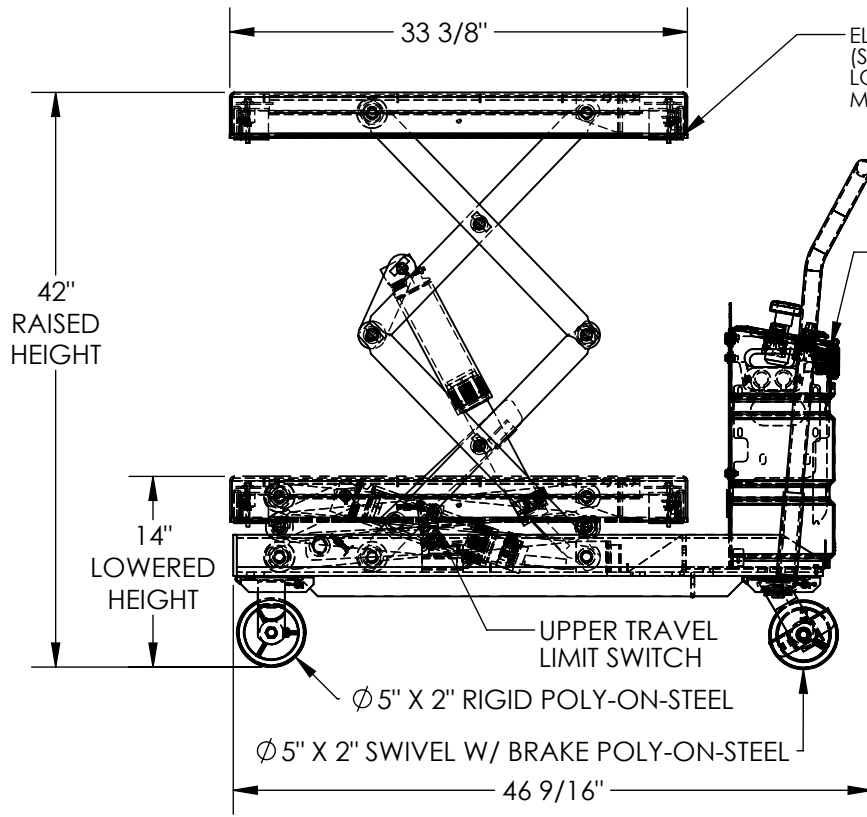

ELECTRIC TOEGUARDS  
(STOP TABLE FROM  
LOWERING IF BUMPED)  
MEETS OSHA 1910.212

STANDARD:  
12V DC HYDRAULIC POWER UNIT  
RAISED AND LOWERED BUTTONS ARE ON  
TOP OF POWER UNIT  
WITH ON BOARD CHARGER  
AND HAND CONTROL

DECK TOLERANCE ±1/2"  
TABLE HEIGHT TOLERANCES ±1/2"  
DECK FLATNESS ±1/4"

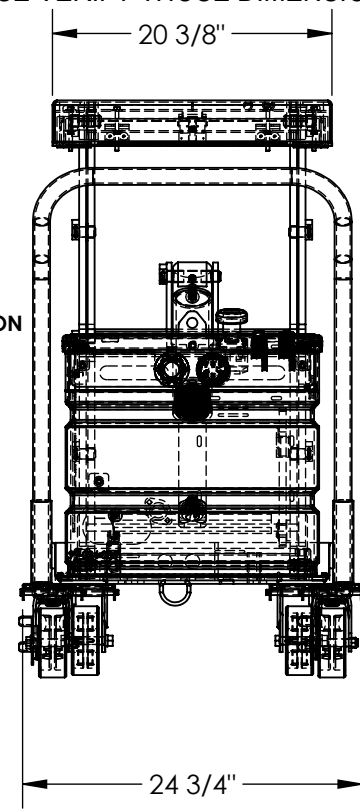

DIMENSION TOLERANCE ± 1/4"

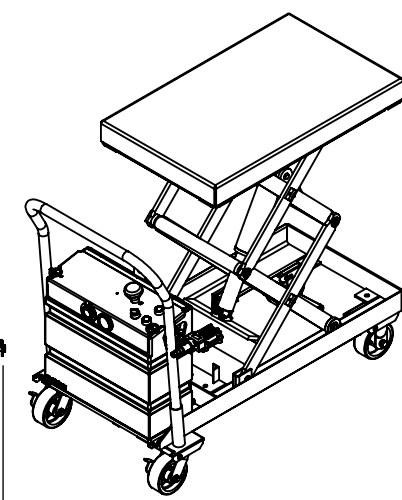

## STANDARD FEATURES

- MODEL NUMBER IS CARTD-1000-2033-DC
- DECK WIDTH IS 20 3/8"
- DECK LENGTH IS 33 3/8"
- RAISED HEIGHT IS 42"
- LOWERED HEIGHT IS 14"
- Ø 5" X 2" RIGID POLY-ON-STEEL CASTERS
- Ø 5" X 2" SWIVEL W/ BRAKE POLY-ON-STEEL CASTERS
- TABLE CAPACITY (EVENLY DISTRIBUTED)
- MAX CAPACITY IS 1,000 LBS
- CONTROL IS HANDHELD 2 BUTTON, NEMA 4 PENDANT WITH MINIMUM 8' USABLE COILD CORD
- SAFETY MAINTENANCE PROPS, DISPLACEMENT STYLE CYLINDERS INSTALLED ROD DOWN
- EMERGENCY SAFETY STOP HYDRAULIC FUSES
- UPPER TRAVEL LIMIT SWITCH
- ELECTRIC PINCH POINT GUARD
- DURABLE LIQUID PAINT BLUE FINISH

## SPECIAL FEATURES

NONE

APPROVAL	I, THE UNDERSIGNED, AGREE THAT THE PRODUCT AS REPRESENTED SATISFIES DESIGN AND DIMENSION REQUIREMENTS. I ALSO ACKNOWLEDGE MY DUTY TO CONFIRM PRODUCT AND INSTALLATION COMPLIANCE WITH ALL APPLICABLE FEDERAL, STATE AND LOCAL REGULATIONS AND STANDARDS.	
	ANY MODIFIED UNITS ARE NON-RETURNABLE	
	[ ] As drawn      [ ] As marked	
	Signed: _____	Date: _____
Printed Name: _____		
<i>LEAD TIME WILL START UPON RECEIPT OF SIGNED APPROVAL DRAWING</i>		

FOR INTERNAL USE ONLY PROJECT SIGN OFF	
SALES	
ENG.	
FAB.	
POWER	

DISTRIBUTOR'S NAME:		P.O.# X
VESTIL MANUFACTURING		W.O.# X
DRAWN BY: KC	DATE: 3/15/16	SALES: X
REFERENCE: X	SCALE: 1:14	FILE NAME:
QUOTED LEAD TIME: X	QUOTE # X	01-007-073