

FOLDING CHAIR AND TABLE DOLLY - CTRT-36

APPROX WEIGHT: 94.26 lbs.
 DOES NOT INCLUDE WEIGHT OF POWER OR PACKAGING!!!

*** ANY ADDITIONS, DELETIONS, OR OMISSIONS MUST BE CORRECTED ON THIS DRAWING AS THIS DRAWING WILL BE CONSIDERED ALL INCLUSIVE ***

ALL GRAPHICS PROVIDED ARE FOR REFERENCE ONLY. IF CERTAIN DIMENSIONS ARE CRITICAL PLEASE VERIFY THOSE DIMENSIONS WITH YOUR SALESPERSON

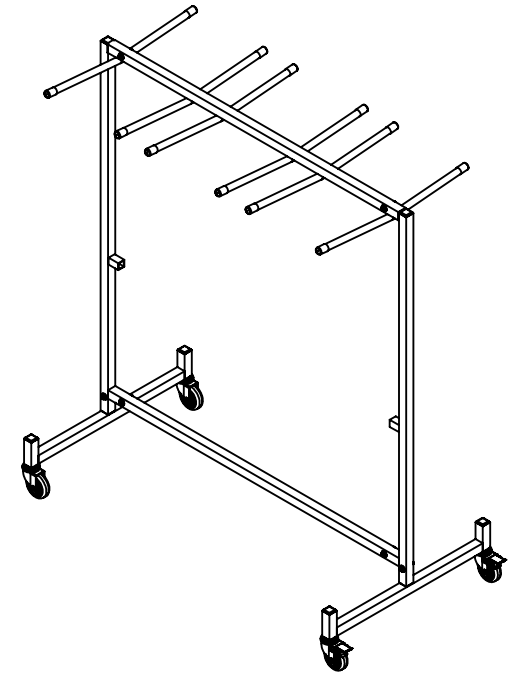
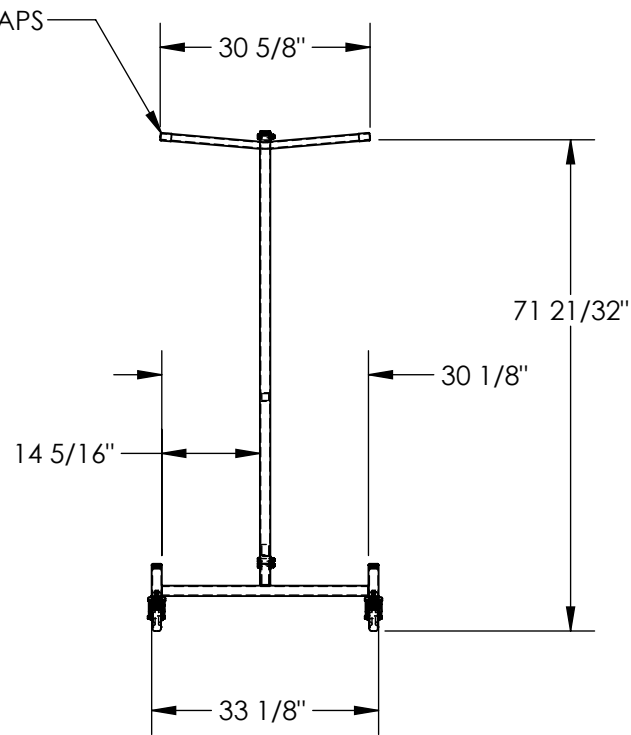
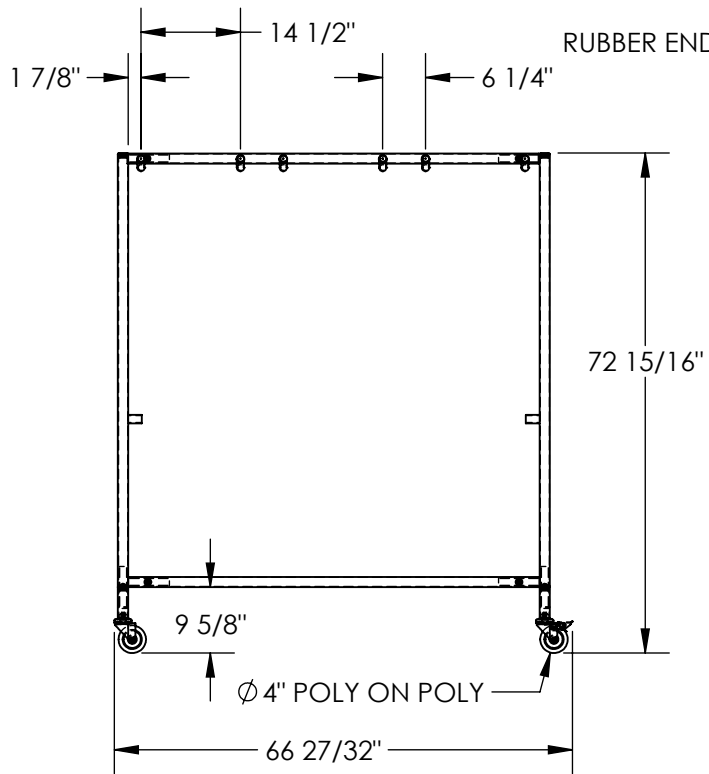

STANDARD FEATURES

- MODEL NUMBER IS CTRT-36
- OVERALL WIDTH IS 33 1/8"
- USABLE WIDTH TABLES IS 30 1/8"
- USABLE WIDTH CHAIRS IS 30 5/8"
- OVERALL LENGTH IS 66 27/32"
- USABLE LENGTH IS 66 27/32"
- OVERALL HEIGHT IS 72 15/16"
- MAX CAPACITY IS 36 CHAIRS & 6 TABLES
- DURABLE LIQUID PAINT BLUE FINISH
- (2) - Ø4" X 1 1/4" SWIVEL CASTER W/ TOTAL BRAKE
- (2) - Ø4" X 1 1/4" SWIVEL CASTER

SPECIAL FEATURES

NONE

DIMENSION TOLERANCE ± 1/4"

APPROVAL

I, THE UNDERSIGNED, AGREE THAT THE PRODUCT AS REPRESENTED SATISFIES DESIGN AND DIMENSION REQUIREMENTS. I ALSO ACKNOWLEDGE MY DUTY TO CONFIRM PRODUCT AND INSTALLATION COMPLIANCE WITH ALL APPLICABLE FEDERAL, STATE AND LOCAL REGULATIONS AND STANDARDS.

UNITS REQUIRING APPROVAL DRAWINGS OR MODIFIED ARE NON-RETURNABLE

As drawn As marked

Signed: _____ Date: _____

Printed Name: _____

LEAD TIME WILL START UPON RECEIPT OF SIGNED APPROVAL DRAWING

FOR INTERNAL USE ONLY PROJECT SIGN OFF	
SALES	
ENG.	
FAB.	
POWER	

DISTRIBUTOR'S NAME:		P.O.#
VESTIL MANUFACTURING		X
DRAWN BY: T. LAPHAM		DATE: 02/12/15
REFERENCE: X		SCALE: 1:28
QUOTED LEAD TIME: X		QUOTE #
		X
		FILE NAME:
		16-007-406