

GALVANIZED SELF-DUMPING STEEL HOPPER W/ BUMPER RELEASE - D-50-HD-GAL

APPROX WEIGHT: 451.14 lbs.

DOES NOT INCLUDE WEIGHT OF POWER OR PACKAGING!!!

*** ANY ADDITIONS, DELETIONS, OR OMISSIONS MUST BE CORRECTED ON THIS DRAWING AS THIS DRAWING WILL BE CONSIDERED ALL INCLUSIVE ***
 ALL GRAPHICS PROVIDED ARE FOR REFERENCE ONLY. IF CERTAIN DIMENSIONS ARE CRITICAL PLEASE VERIFY THOSE DIMENSIONS WITH YOUR SALESPERSON

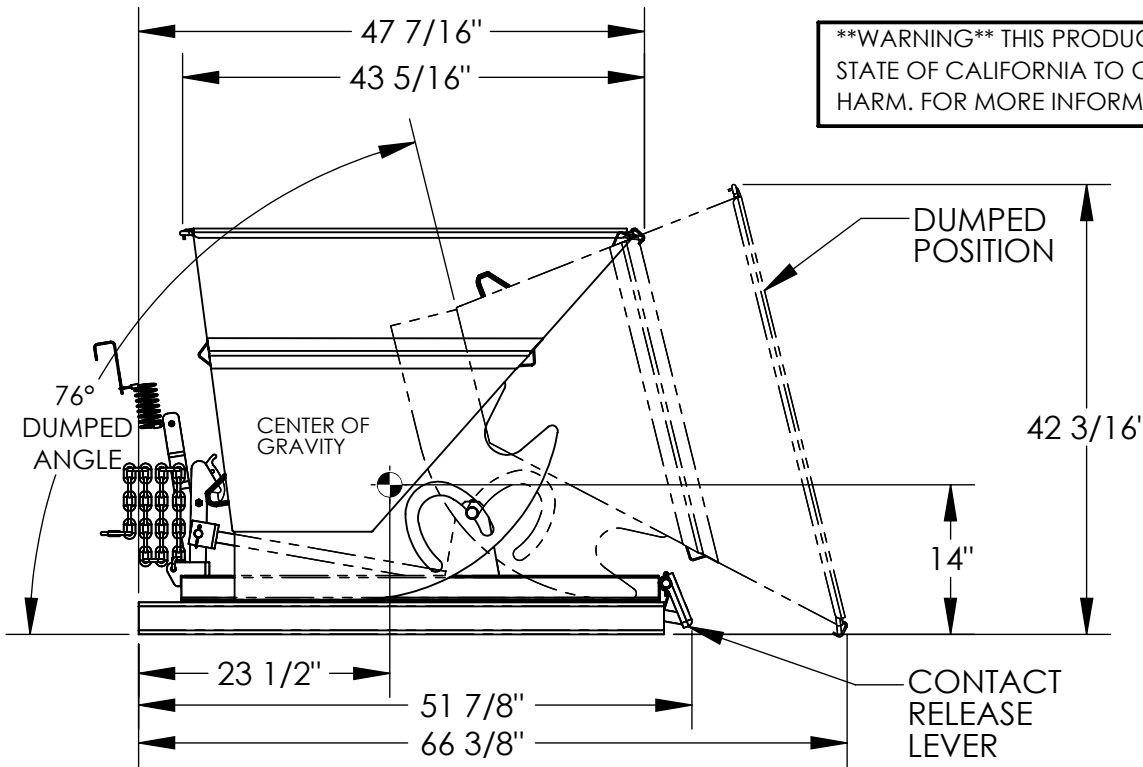

****WARNING** THIS PRODUCT CAN EXPOSE YOU TO LEAD, WHICH IS KNOWN TO THE STATE OF CALIFORNIA TO CAUSE CANCER AND BIRTH DEFECTS OR OTHER REPRODUCTIVE HARM. FOR MORE INFORMATION GO TO www.p65warnings.ca.gov**

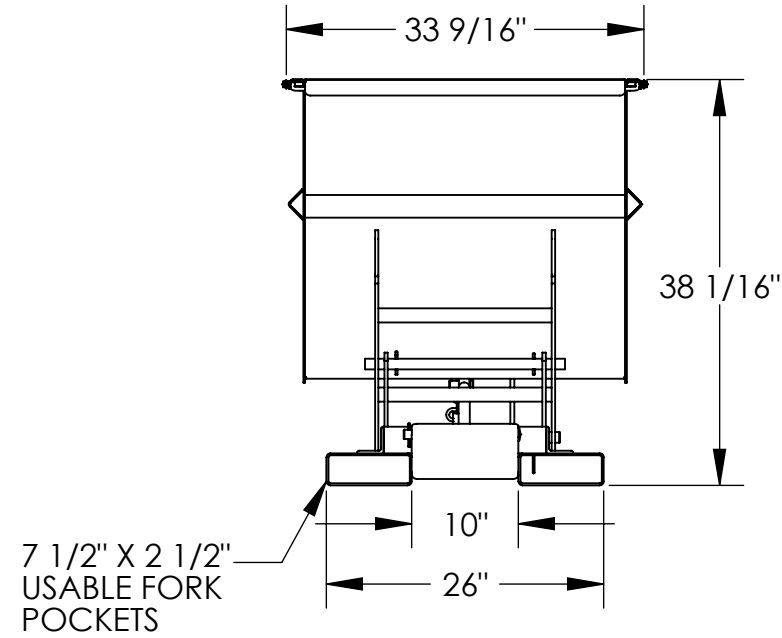

DIMENSION TOLERANCE ± 1/4"

STANDARD FEATURES

- MODEL NUMBER: D-50-HD-GAL
- VOLUME: 1/2 CU. YDS.
- CAPACITY: 6,000 LBS.
- OVERALL WIDTH: 33 9/16"
- OVERALL LENGTH: 51 7/8"
- OVERALL HEIGHT: 38 1/16"
- PULL CABLE IS AT LEAST: 48"
- FINISH: HOT DIP GALVANIZED

NEVER EXCEED LOAD CENTER RATING PER FORK TRUCK MANUFACTURER'S GUIDELINES. DO NOT USE THIS FORK TRUCK ATTACHMENT IF LOAD WILL EXCEED FORK TRUCK MANUFACTURER'S LOAD CENTER RATING.

APPROX. WEIGHT/ LOST LOAD=451.14 LBS.
 MINIMUM EFFECTIVE THICKNESS= LESS THAN 1"

SPECIAL FEATURES

NONE

APPROVAL

I, THE UNDERSIGNED, AGREE THAT THE PRODUCT AS REPRESENTED SATISFIES DESIGN AND DIMENSION REQUIREMENTS. I ALSO ACKNOWLEDGE MY DUTY TO CONFIRM PRODUCT AND INSTALLATION COMPLIANCE WITH ALL APPLICABLE FEDERAL, STATE AND LOCAL REGULATIONS AND STANDARDS.

ANY MODIFIED UNITS ARE NON-RETURNABLE

[] As drawn [] As marked

Signed: _____ Date: _____

Printed Name: _____

LEAD TIME WILL START UPON RECEIPT OF SIGNED APPROVAL DRAWING

FOR INTERNAL USE ONLY PROJECT SIGN OFF	
SALES	
ENG.	
FAB.	
POWER	

DISTRIBUTOR'S NAME:		P.O.#
VESTIL MANUFACTURING		X
DRAWN BY: SJG		W.O.#
DATE: 2/9/2018		X
REFERENCE: X	SCALE: 1:14	SALES: X
QUOTED LEAD TIME: X	QUOTE #	FILE NAME:
	X	37-007-122-001

ADDITION OF CASTERS MAY CHANGE WEIGHT CAPACITY BASED ON CASTER RATING