

ERGO DRAIN CART - DH-PH4-2472-D

APPROX WEIGHT: 235.30 lbs.
DOES NOT INCLUDE WEIGHT OF POWER OR PACKAGING!!!

*** ANY ADDITIONS, DELETIONS, OR OMISSIONS MUST BE CORRECTED ON THIS DRAWING AS THIS DRAWING WILL BE CONSIDERED ALL INCLUSIVE ***

ALL GRAPHICS PROVIDED ARE FOR REFERENCE ONLY. IF CERTAIN DIMENSIONS ARE CRITICAL PLEASE VERIFY THOSE DIMENSIONS WITH YOUR SALESPERSON

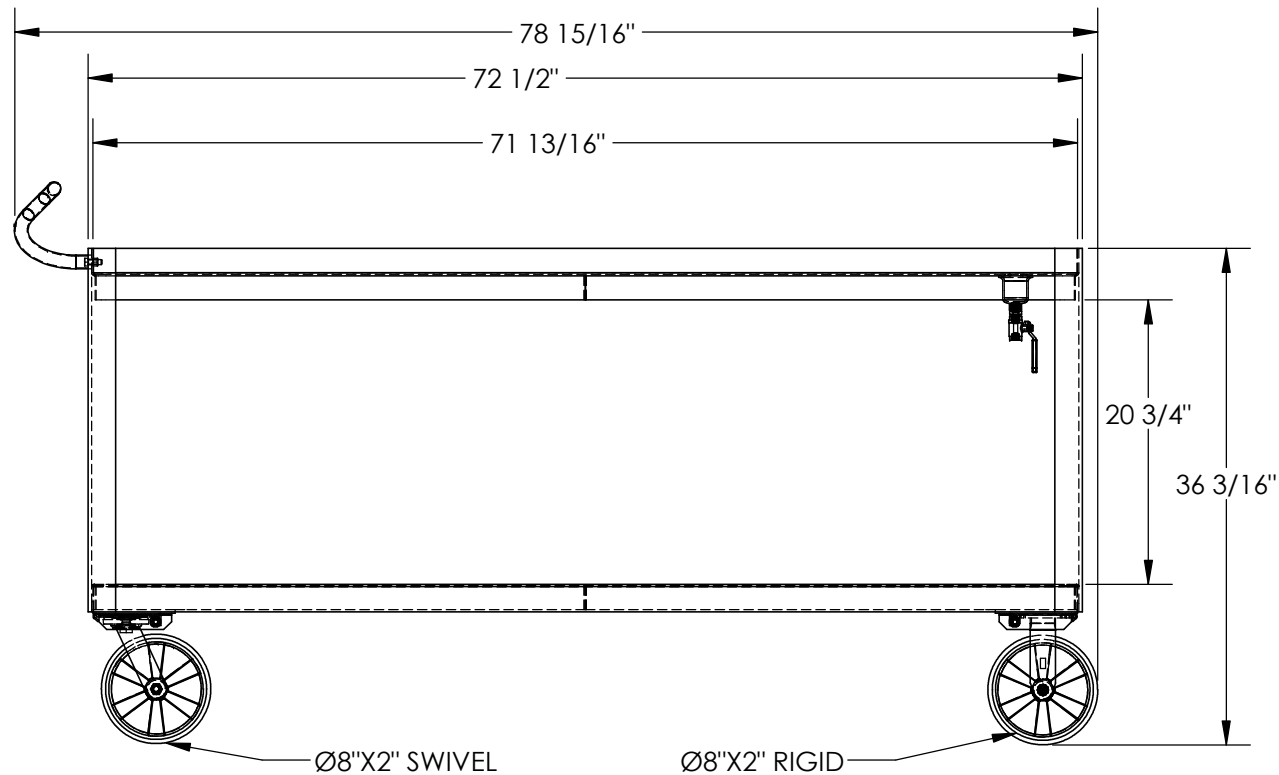
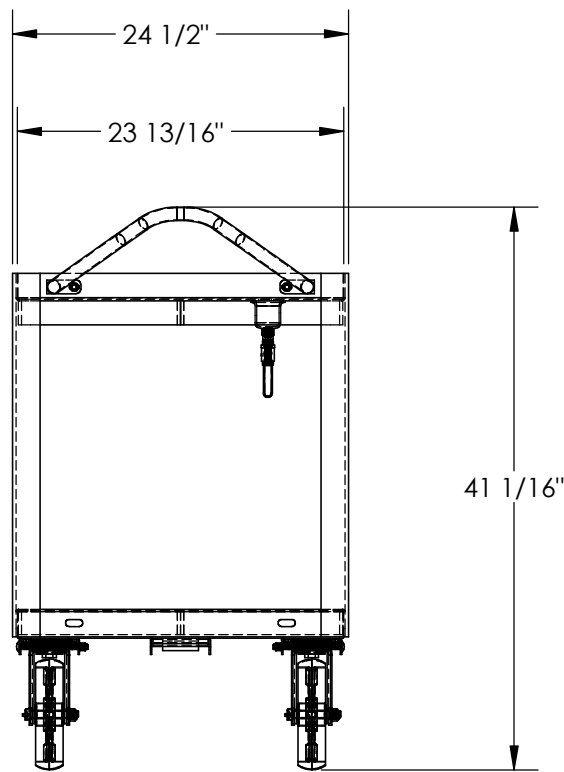

STANDARD FEATURES

MODEL NUMBER IS DH-PH4-2472-D
 MAXIMUM CART CAPACITY IS 4,000 LBS.
 MAXIMUM SHELF CAPACITY IS 2,000 LBS.
 NOT TO EXCEED MAXIMUM CAPACITY OF THE CART
 OVERALL WIDTH IS: 24 1/2"
 USABLE WIDTH IS: 23 13/16"
 OVERALL LENGTH IS: 78 15/16"
 USABLE LENGTH IS: 71 13/16"
 OVERALL HEIGHT IS: 41 1/16"
 SHELF CLEARANCE IS: 20 3/4"
 2 RIGID 8"X2" GLASS FILLED NYLON CASTERS
 2 SWIVEL 8"X2" GLASS FILLED NYLON CASTERS
 STEEL CONSTRUCTION

SPECIAL FEATURES

NONE

DIMENSION TOLERANCE ± 1/4"

APPROVAL	I, THE UNDERSIGNED, AGREE THAT THE PRODUCT AS REPRESENTED SATISFIES DESIGN AND DIMENSION REQUIREMENTS. I ALSO ACKNOWLEDGE MY DUTY TO CONFIRM PRODUCT AND INSTALLATION COMPLIANCE WITH ALL APPLICABLE FEDERAL, STATE AND LOCAL REGULATIONS AND STANDARDS.	
	ANY MODIFIED UNITS ARE NON-RETURNABLE	
	[] As drawn [] As marked	
	Signed: _____	Date: _____
Printed Name: _____		
LEAD TIME WILL START UPON RECEIPT OF SIGNED APPROVAL DRAWING		

FOR INTERNAL USE ONLY PROJECT SIGN OFF	
SALES	
ENG.	
FAB.	
POWER	

DISTRIBUTOR'S NAME:		P.O.#
VESTIL MANUFACTURING		X
DRAWN BY: DLS		W.O.#
DATE: 08/01/12		X
REFERENCE: X	SCALE: 1:14	SALES: X
QUOTED LEAD TIME: X	QUOTE #	FILE NAME:
	X	16-007-336