

GROUND LIFT SCISSOR TABLE - EHLTG-4470-4-48

APPROX WEIGHT: 1940.56 lbs.
DOES NOT INCLUDE WEIGHT OF POWER OR PACKAGING!!!

*** ANY ADDITIONS, DELETIONS, OR OMISSIONS MUST BE CORRECTED ON THIS DRAWING AS THIS DRAWING WILL BE CONSIDERED ALL INCLUSIVE ***

ALL GRAPHICS PROVIDED ARE FOR REFERENCE ONLY. IF CERTAIN DIMENSIONS ARE CRITICAL PLEASE VERIFY THOSE DIMENSIONS WITH YOUR SALESPERSON

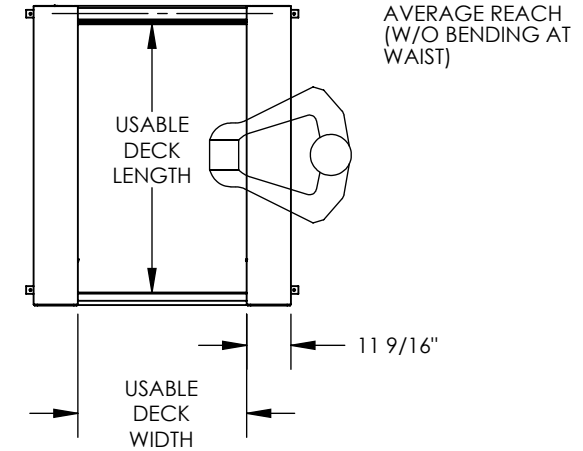
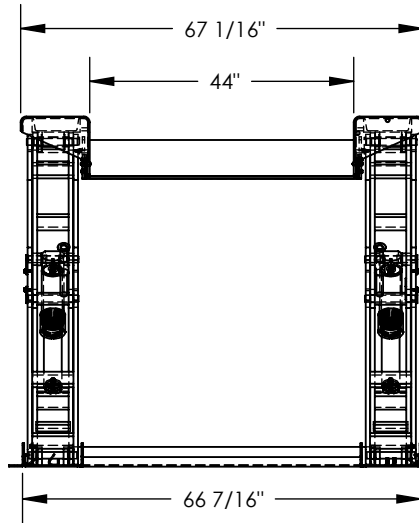
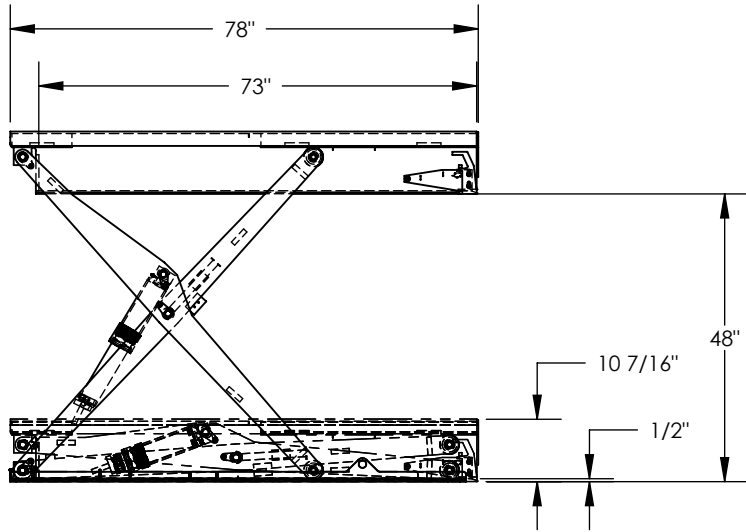

6" HIGH BACK PLATE

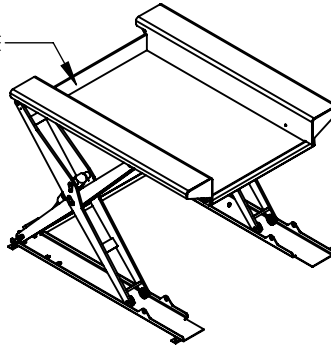

REMOTE POWER UNIT:
32 1/2" x 12" x 12 1/2" (L x W x H)
WITH 8' HOSE & CABLE

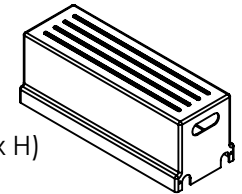

STANDARD FEATURES

- MODEL NUMBER IS: EHLTG-4470-4-48
- PLATFORM WIDTH (USABLE): 44"
- PLATFORM LENGTH (USABLE): 73"
- OVERALL WIDTH: 67 1/16"
- OVERALL LENGTH: 78"
- PLATFORM RAISED HEIGHT: 48"
- PLATFORM LOWERED HEIGHT: 10 7/16"
- CAPACITY: 4,000 LBS.
- DURABLE LIQUID PANT BLUE FINISH

SPECIAL FEATURES

NONE

PLEASE CIRCLE SPECIFICATIONS:

POWER	<input checked="" type="checkbox"/> AC	<input type="checkbox"/> DC (12V)	<input type="checkbox"/> AIR/OIL
MOTOR VOLTAGE	<input type="checkbox"/> 115	<input type="checkbox"/> 208	<input checked="" type="checkbox"/> 460
DEDICATED CIRCUIT REQUIRED 60Hz			
MOTOR PHASE	<input type="checkbox"/> SINGLE	<input checked="" type="checkbox"/> THREE	
CONTROL	<input type="checkbox"/> HAND	<input checked="" type="checkbox"/> FOOT	

DIMENSION TOLERANCE ± 1/4"

I, THE UNDERSIGNED, AGREE THAT THE PRODUCT AS REPRESENTED SATISFIES DESIGN AND DIMENSION REQUIREMENTS. I ALSO ACKNOWLEDGE MY DUTY TO CONFIRM PRODUCT AND INSTALLATION COMPLIANCE WITH ALL APPLICABLE FEDERAL, STATE AND LOCAL REGULATIONS AND STANDARDS.

ANY MODIFIED UNITS ARE NON-RETURNABLE

[] As drawn [] As marked

Signed: _____ Date: _____

Printed Name: _____

LEAD TIME WILL START UPON RECEIPT OF SIGNED APPROVAL DRAWING

DISTRIBUTOR'S NAME: VESTIL MANUFACTURING

P.O.# X

W.O.# X

SALES: X

FILE NAME: 04-007-055

DRAWN BY: V.GONI DATE: 08/27/2013

REFERENCE: X SCALE: 1:32

QUOTED LEAD TIME: X QUOTE # X

FOR INTERNAL USE ONLY
PROJECT SIGN OFF

SALES	
ENG.	
FAB.	
POWER	