

ELECTRIC PALLET TRUCK WITH SCALE - EPT-2748-45-SCL-RP

APPROX WEIGHT: 1056 lbs.
 DOES NOT INCLUDE WEIGHT OF POWER OR PACKAGING!!!

*** ANY ADDITIONS, DELETIONS, OR OMISSIONS MUST BE CORRECTED ON THIS DRAWING AS THIS DRAWING WILL BE CONSIDERED ALL INCLUSIVE ***

ALL GRAPHICS PROVIDED ARE FOR REFERENCE ONLY. IF CERTAIN DIMENSIONS ARE CRITICAL PLEASE VERIFY THOSE DIMENSIONS WITH YOUR SALESPERSON

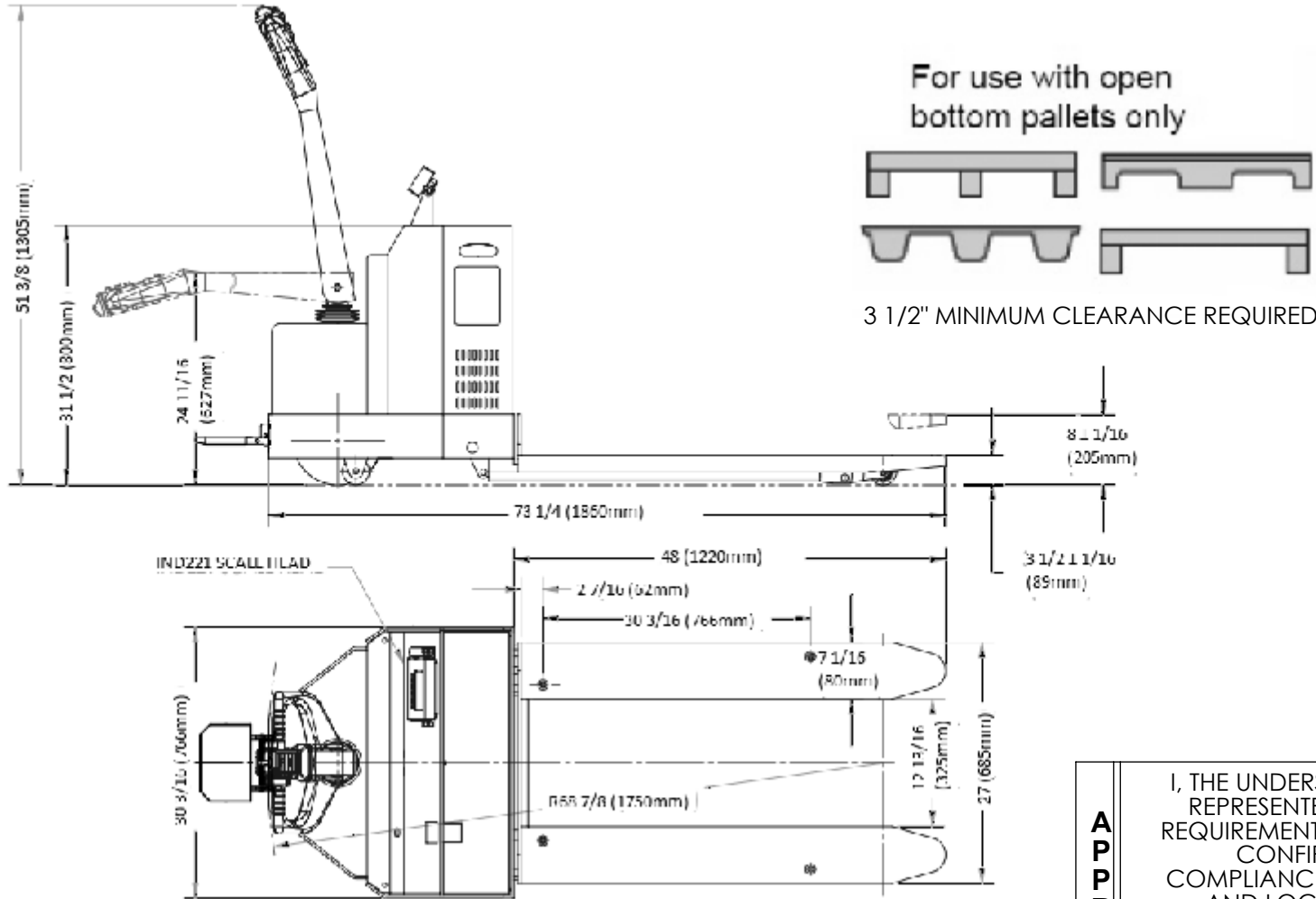

DIMENSION TOLERANCE ± 1/2"

STANDARD FEATURES

- MODEL NUMBER IS EPT-2748-45-SCL-RP
- CAPACITY: 4,500 LBS CONTINUOUS
- LIFT HEIGHT: 8 ± 1/16"
- LOWERED HEIGHT: 3 3/8 ± 1/16"
- DRIVE WHEEL: Ø10 X 3 1/8"
- LOAD ROLLER: Ø2 3/4 X 2.9"
- TOUGH BAKED IN POWDER COATED BLACK AND YELLOW FINISH

SPECIAL FEATURES

NONE

A P P R O V A L

I, THE UNDERSIGNED, AGREE THAT THE PRODUCT AS REPRESENTED SATISFIES DESIGN AND DIMENSION REQUIREMENTS. I ALSO ACKNOWLEDGE MY DUTY TO CONFIRM PRODUCT AND INSTALLATION COMPLIANCE WITH ALL APPLICABLE FEDERAL, STATE AND LOCAL REGULATIONS AND STANDARDS.

UNITS REQUIRING APPROVAL DRAWINGS OR MODIFIED ARE NON-RETURNABLE

[] As drawn [] As marked

Signed: _____ Date: _____

Printed Name: _____

LEAD TIME WILL START UPON RECEIPT OF SIGNED APPROVAL DRAWING

FOR INTERNAL USE ONLY PROJECT SIGN OFF	
SALES	
ENG.	
FAB.	
POWER	

DISTRIBUTOR'S NAME:		P.O.#
VESTIL MANUFACTURING		X
DRAWN BY: TM		W.O.#
DATE: 12/26/2018		X
REFERENCE: X	SCALE: 1:48	SALES: X
QUOTED LEAD TIME: X	QUOTE #	FILE NAME:
	X	EPT-2748-45-SCL-RP