

FIXED ALUMINUM GANTRY CRANE - FHA-4-12-10

APPROX WEIGHT: 366 lbs.
 DOES NOT INCLUDE WEIGHT OF POWER OR PACKAGING!!!

*** ANY ADDITIONS, DELETIONS, OR OMISSIONS MUST BE CORRECTED ON THIS DRAWING AS THIS DRAWING WILL BE CONSIDERED ALL INCLUSIVE ***

ALL GRAPHICS PROVIDED ARE FOR REFERENCE ONLY. IF CERTAIN DIMENSIONS ARE CRITICAL PLEASE VERIFY THOSE DIMENSIONS WITH YOUR SALESPERSON

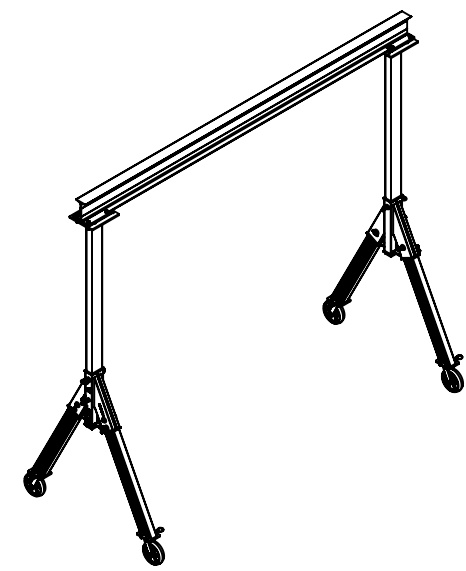
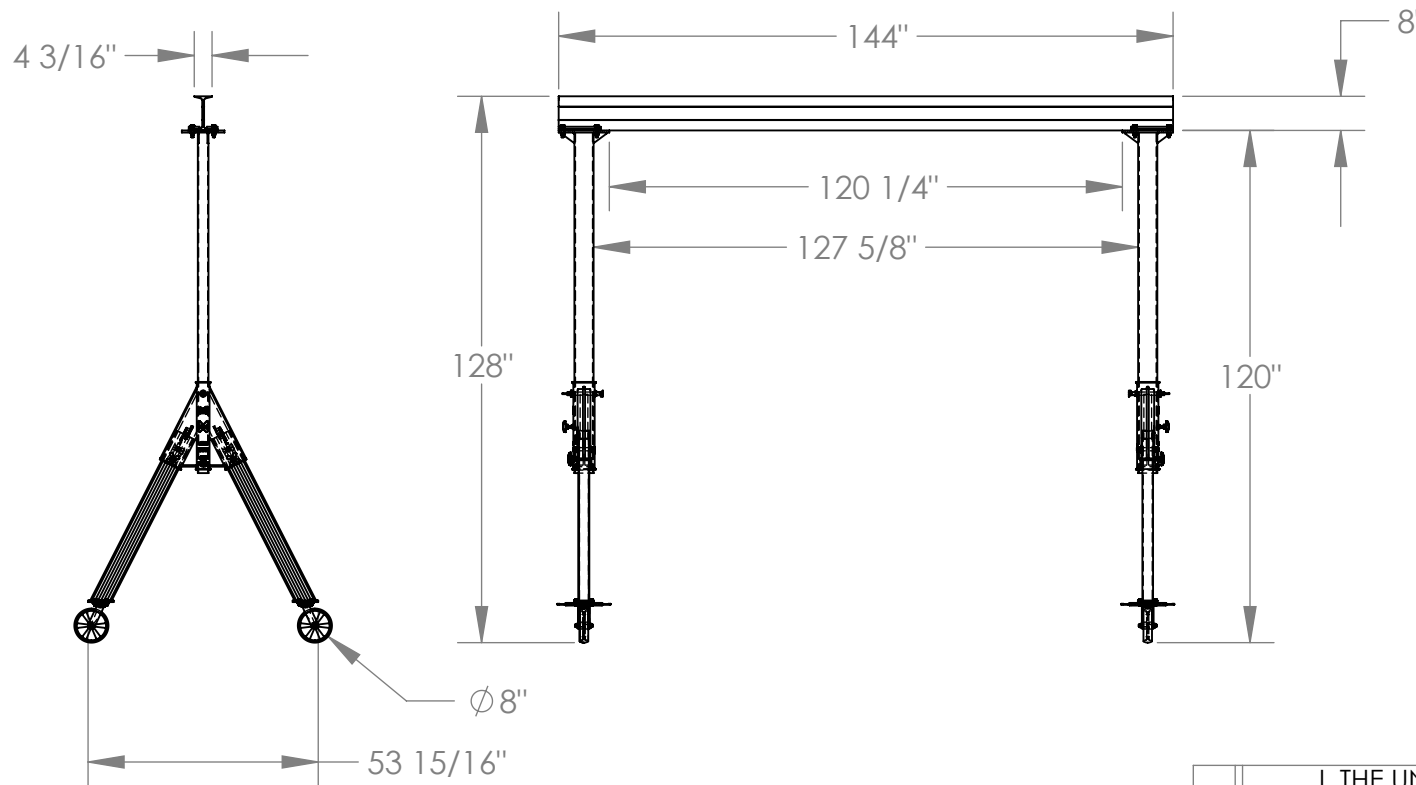

3D VIEW FOR REFERENCE ONLY

STANDARD FEATURES

- MODEL NUMBER IS FHA-4-12-10
- CAPACITY IS 4,000 LBS.
- BASE WIDTH IS 53 15/16"
- OVERALL HEIGHT IS 128"
- I-BEAM HEIGHT IS 8"
- I-BEAM FLANGE WIDTH IS 4 3/16"
- OVERALL I-BEAM LENGTH IS 144"
- USABLE I-BEAM LENGTH IS 120 1/4"
- UNDER I-BEAM HEIGHT IS 120"
- CASTERS: (4) Ø8" X 2" WIDE GLASS FILLED NYLON SWIVEL CASTERS WITH FOUR LOCKING POSITIONS

SPECIAL FEATURES

NONE

DIMENSION TOLERANCE ± 1/4"

I, THE UNDERSIGNED, AGREE THAT THE PRODUCT AS REPRESENTED SATISFIES DESIGN AND DIMENSION REQUIREMENTS. I ALSO ACKNOWLEDGE MY DUTY TO CONFIRM PRODUCT AND INSTALLATION COMPLIANCE WITH ALL APPLICABLE FEDERAL, STATE AND LOCAL REGULATIONS AND STANDARDS.

ANY MODIFIED UNITS ARE NON-RETURNABLE

[] As drawn [] As marked

Signed: _____ Date: _____

Printed Name: _____

LEAD TIME WILL START UPON RECEIPT OF SIGNED APPROVAL DRAWING

APPROVAL

FOR INTERNAL USE ONLY PROJECT SIGN OFF	
SALES	
ENG.	
FAB.	
POWER	

DISTRIBUTOR'S NAME:		P.O.#
VESTIL MANUFACTURING		X
DRAWN BY: MTS		W.O.#
DATE: 08/18/2014		X
REFERENCE: X	SCALE: 1:45	SALES: X
QUOTED LEAD TIME: X	QUOTE #	FILE NAME:
	X	28-007-406