

HYDRAULIC DRUM STACKER - HDC-450-96

APPROX WEIGHT: 758.45 lbs.
DOES NOT INCLUDE WEIGHT OF POWER OR PACKAGING!!!

ANY ADDITIONS, DELETIONS, OR OMISSIONS MUST BE CORRECTED ON THIS DRAWING AS THIS DRAWING WILL BE CONSIDERED ALL INCLUSIVE

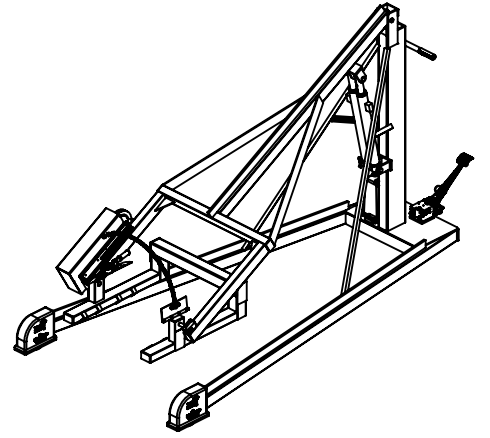
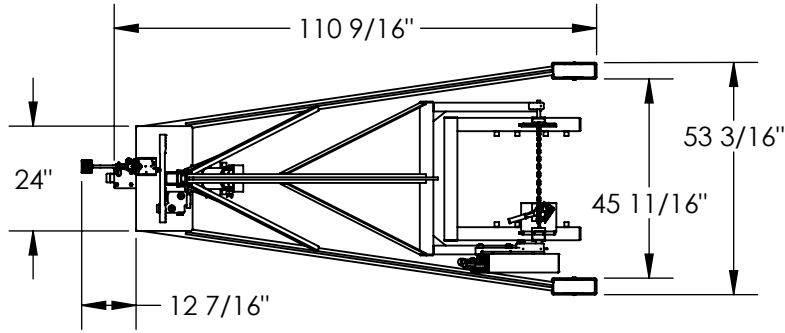

SHOWN IN LOWERED POSITION

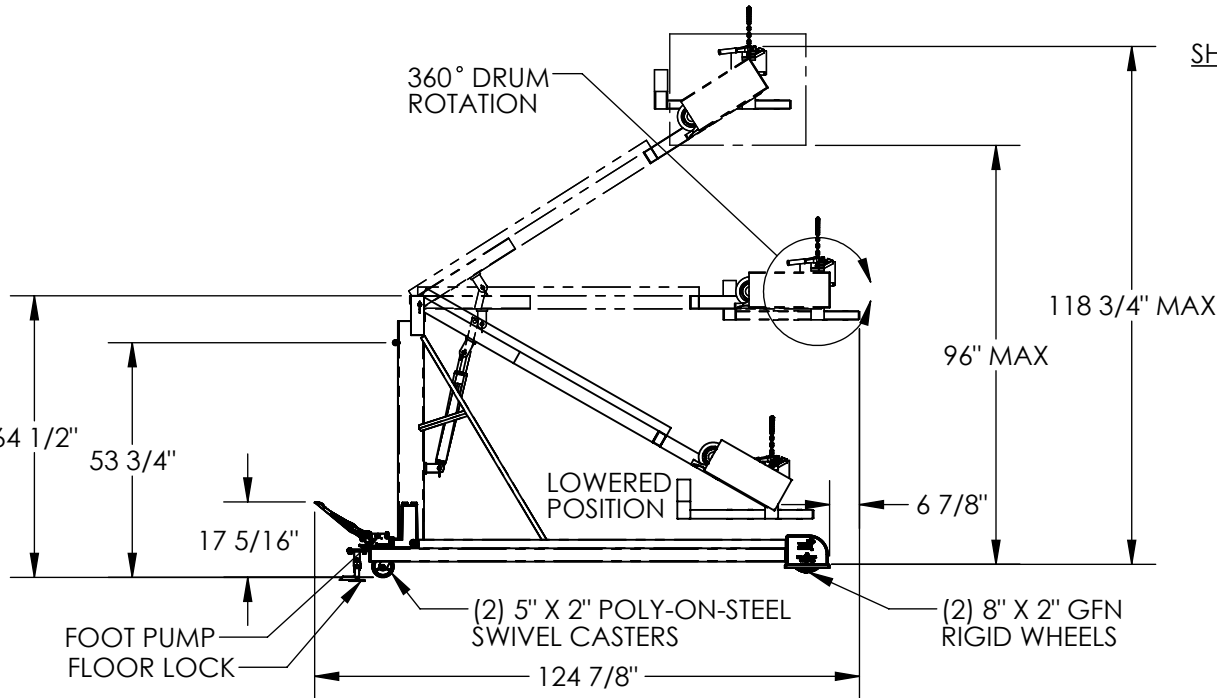

ALL GRAPHICS PROVIDED ARE FOR REFERENCE ONLY. IF CERTAIN DIMENSIONS ARE CRITICAL PLEASE VERIFY THOSE DIMENSIONS WITH YOUR SALESPERSON

STANDARD FEATURES

- MODEL NUMBER IS HDC-450-96
- CAPACITY IS 800 LBS
- OVERALL WIDTH IS 53 3/16"
- MAXIMUM OVERALL LENGTH IS 124 7/8"
- OVERALL HEIGHT IS 118 3/4"
- OUT RIGGER INSIDE DIMENSION IS 45 11/16"
- PUSH HANDLE HEIGHT IS 53 3/4"
- DRUM RAISED HEIGHT IS 96"
- (2) 5" X 2" REAR SWIVEL POLY-ON-STEEL CASTERS
- (2) 8" X 2" FRONT RIGID GFN WHEELS
- PULL CHAIN DRUM ROTATION (360°)
- FOOT PUMP
- FLOOR LOCK
- DURABLE LIQUID PAINT BLUE FINISH

SPECIAL FEATURES

NONE

FOR INTERNAL USE ONLY PROJECT SIGN OFF	
SALES	
ENG.	
FAB.	
POWER	

DIMENSION TOLERANCE ± 1/4"

I, THE UNDERSIGNED, AGREE THAT THE PRODUCT AS REPRESENTED SATISFIES DESIGN AND DIMENSION REQUIREMENTS. I ALSO ACKNOWLEDGE MY DUTY TO CONFIRM PRODUCT AND INSTALLATION COMPLIANCE WITH ALL APPLICABLE FEDERAL, STATE AND LOCAL REGULATIONS AND STANDARDS.

ANY MODIFIED UNITS ARE NON-RETURNABLE

[] As drawn [] As marked

Signed: _____ Date: _____

Printed Name: _____

LEAD TIME WILL START UPON RECEIPT OF SIGNED APPROVAL DRAWING

DISTRIBUTOR'S NAME:		P.O.#
VESTIL MANUFACTURING		X
DRAWN BY: DEY		W.O.#
DATE: 12/12/11		X
REFERENCE: X	SCALE: 1:44	SALES: X
QUOTED LEAD TIME: X	QUOTE # X	FILE NAME:
		09-007-034-001