

STATIONARY HYDRAULIC DRUM DUMPER- HDD-48-15-S

APPROX WEIGHT: 699.08 lbs.
 DOES NOT INCLUDE WEIGHT OF POWER OR PACKAGING!!!

ANY ADDITIONS, DELETIONS, OR OMISSIONS MUST BE CORRECTED ON THIS DRAWING AS THIS DRAWING WILL BE CONSIDERED ALL INCLUSIVE

ALL GRAPHICS PROVIDED ARE FOR REFERENCE ONLY. IF CERTAIN DIMENSIONS ARE CRITICAL PLEASE VERIFY THOSE DIMENSIONS WITH YOUR SALESPERSON

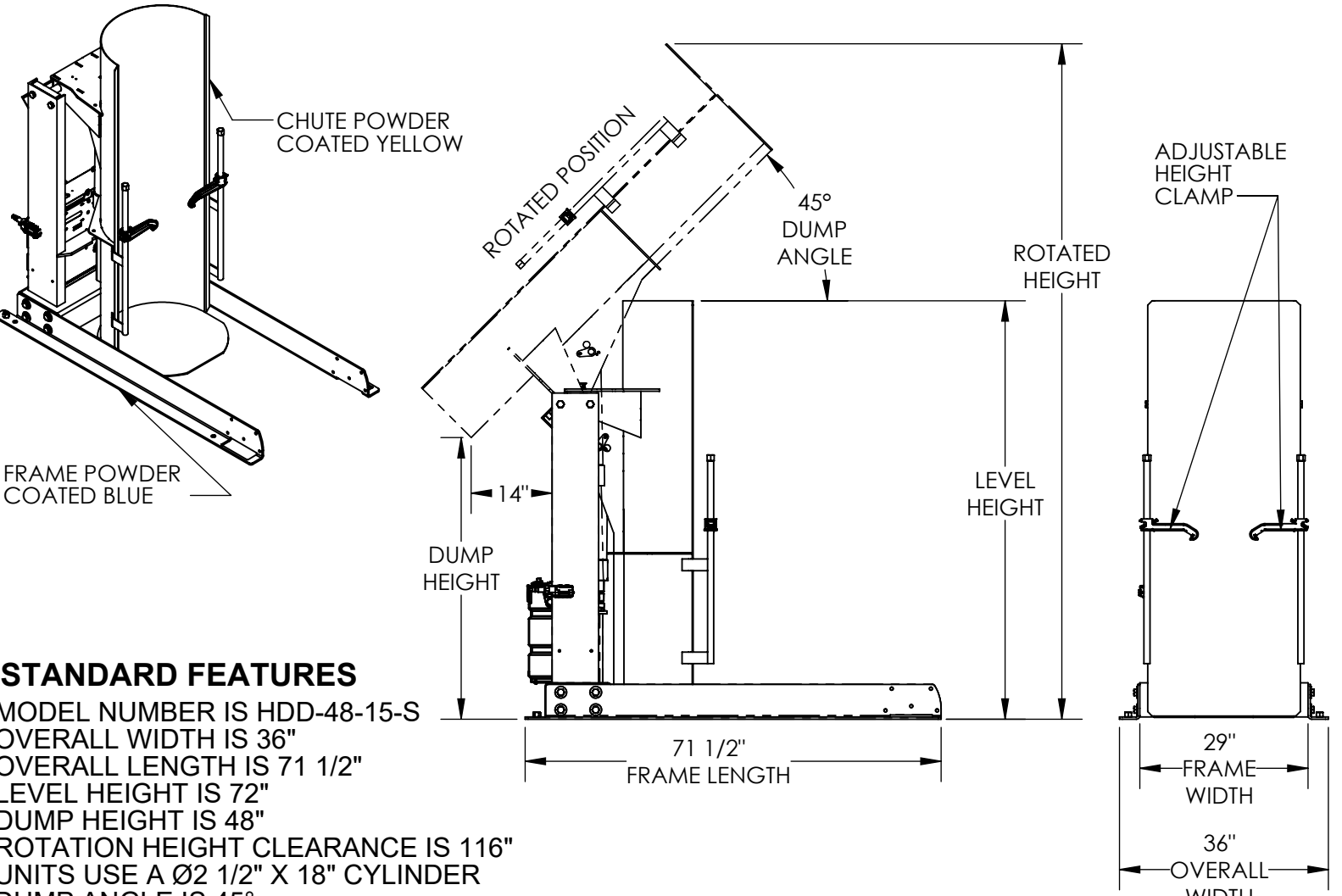

STANDARD FEATURES

- MODEL NUMBER IS HDD-48-15-S
- OVERALL WIDTH IS 36"
- OVERALL LENGTH IS 71 1/2"
- LEVEL HEIGHT IS 72"
- DUMP HEIGHT IS 48"
- ROTATION HEIGHT CLEARANCE IS 116"
- UNITS USE A Ø 1 1/2" X 18" CYLINDER
- DUMP ANGLE IS 45°
- MAX CAPACITY IS 1500 LBS,
- ALL STEEL CONSTRUCTION
- PENDANT HAND CONTROL WITH 8' CORD
- ACCEPTABLE DRUM SIZE:

SPECIAL FEATURES

NONE

- Ø16 1/2" TO Ø23 1/2" (ROUND) X 27 1/2" TO 39 1/2" H (TALL)
- BASE POWDER COATED BLUE
- CHUTE POWDER COATED YELLOW
- TOUGH BAKED IN POWDER COATED FINISH
- 3,000 P.S.I. HYDRAULIC COMPONENTS RATING**
- WARNING: CHECK STATE AND LOCAL CODES !!!**
- UNIT MUST BE SECURED TO FLOOR BEFORE USE**

FOR INTERNAL USE ONLY	
PROJECT SIGN OFF	
SALES	
ENG.	
FAB.	
POWER	

DIMENSION TOLERANCE ± 1/4"

PLEASE CIRCLE SPECIFICATIONS:

POWER	AC	*DC	*AIR/OIL
MOTOR VOLTAGE	115	208	230 460
DEDICATED CIRCUIT REQUIRED			
MOTOR PHASE	SINGLE	THREE	
CONTROL	HAND	* FOOT	
~ ALL BATTERY CHARGERS ARE 115V AC ~			
* BATTERY CHRG.	REMOTE	ON-BOARD	
* CHRG. INDICATOR	YES	NO	

* AVAILABLE AT ADDITIONAL COST

APPROVAL

I, THE UNDERSIGNED, AGREE THAT THE PRODUCT AS REPRESENTED SATISFIES DESIGN AND DIMENSION REQUIREMENTS. I ALSO ACKNOWLEDGE MY DUTY TO CONFIRM PRODUCT AND INSTALLATION COMPLIANCE WITH ALL APPLICABLE FEDERAL, STATE AND LOCAL REGULATIONS AND STANDARDS.

ANY MODIFIED UNITS ARE NON-RETURNABLE

[] As drawn [] As marked

Signed: _____ Date: _____

Printed Name: _____

LEAD TIME WILL START UPON RECEIPT OF SIGNED APPROVAL DRAWING

DISTRIBUTOR'S NAME:		P.O.#
VESTIL MANUFACTURING		X
DRAWN BY: CRM		W.O.#
DATE: 10/21/2010		X
REFERENCE: X	SCALE: 1:28	SALES: X
QUOTED LEAD TIME: X	QUOTE #	FILE NAME:
	X	09-007-123-002