

PORTABLE HYDRAULIC DRUM DUMPER - HDD-60-7-P

APPROX WEIGHT: 887.47 lbs.
 DOES NOT INCLUDE WEIGHT OF POWER OR PACKAGING!!!

ANY ADDITIONS, DELETIONS, OR OMISSIONS MUST BE CORRECTED ON THIS DRAWING AS THIS DRAWING WILL BE CONSIDERED ALL INCLUSIVE

ALL GRAPHICS PROVIDED ARE FOR REFERENCE ONLY. IF CERTAIN DIMENSIONS ARE CRITICAL PLEASE VERIFY THOSE DIMENSIONS WITH YOUR SALESPERSON

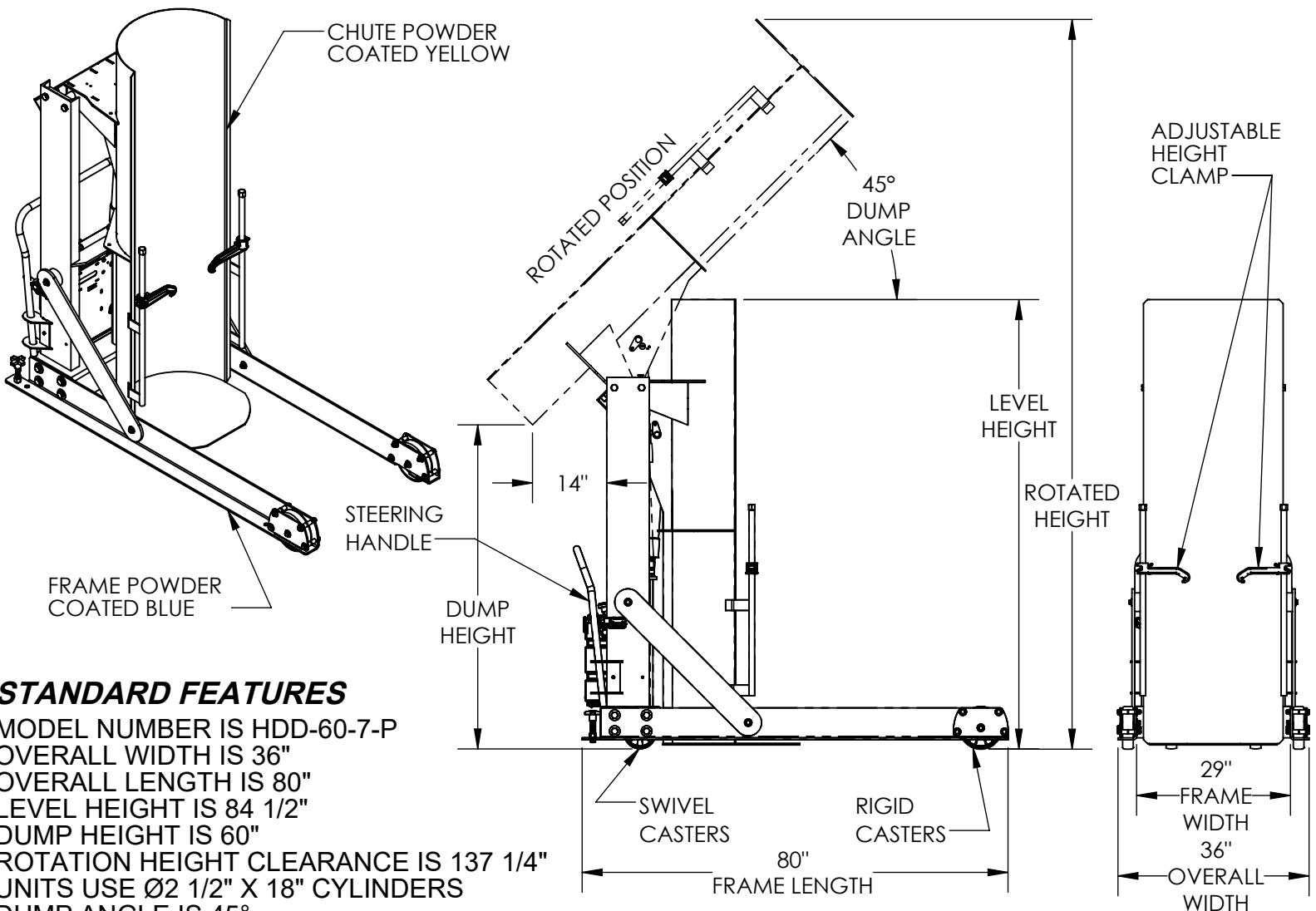

STANDARD FEATURES

- MODEL NUMBER IS HDD-60-7-P
- OVERALL WIDTH IS 36"
- OVERALL LENGTH IS 80"
- LEVEL HEIGHT IS 84 1/2"
- DUMP HEIGHT IS 60"
- ROTATION HEIGHT CLEARANCE IS 137 1/4"
- UNITS USE Ø2 1/2" X 18" CYLINDERS
- DUMP ANGLE IS 45°

- MAX CAPACITY IS 750 LBS.
- ALL STEEL CONSTRUCTION
- PENDANT HAND CONTROL WITH 8' CORD
- ACCEPTS DRUM SIZE: Ø16 1/2" TO Ø23 1/2" (ROUND) X 27 1/2" TO 39 1/2" H (TALL)
- INCLUDES: (2) SWIVEL CASTERS, (2) RIGID CASTERS, (1) STEERING HANDLE
- BASE POWDER COATED BLUE
- CHUTE POWDER COATED YELLOW
- TOUGH BAKED IN POWDER COATED FINISH

3,000 P.S.I. HYDRAULIC COMPONENTS RATING
WARNING: CHECK STATE AND LOCAL CODES !!!

PLEASE CIRCLE SPECIFICATIONS:

POWER	<input checked="" type="checkbox"/> AC	<input type="checkbox"/> *DC	<input type="checkbox"/> *AIR/OIL
MOTOR VOLTAGE	<input checked="" type="checkbox"/> 115	<input type="checkbox"/> 208	<input type="checkbox"/> 230 460
DEDICATED CIRCUIT REQUIRED			
MOTOR PHASE	<input checked="" type="checkbox"/> SINGLE	<input type="checkbox"/> THREE	
CONTROL	<input checked="" type="checkbox"/> HAND	<input type="checkbox"/> * FOOT	
~ ALL BATTERY CHARGERS ARE 115V AC ~			
* BATTERY CHRG.	<input type="checkbox"/> REMOTE	<input type="checkbox"/> ON-BOARD	
* CHRG. INDICATOR	<input type="checkbox"/> YES	<input type="checkbox"/> NO	

* AVAILABLE AT ADDITIONAL COST

SPECIAL FEATURES

NONE

FOR INTERNAL USE ONLY
 PROJECT SIGN OFF

SALES	
ENG.	
FAB.	
POWER	

APPROVAL

I, THE UNDERSIGNED, AGREE THAT THE PRODUCT AS REPRESENTED SATISFIES DESIGN AND DIMENSION REQUIREMENTS. I ALSO ACKNOWLEDGE MY DUTY TO CONFIRM PRODUCT AND INSTALLATION COMPLIANCE WITH ALL APPLICABLE FEDERAL, STATE AND LOCAL REGULATIONS AND STANDARDS.

ANY MODIFIED UNITS ARE NON-RETURNABLE

[] As drawn [] As marked

Signed: _____ Date: _____

Printed Name: _____

LEAD TIME WILL START UPON RECEIPT OF SIGNED APPROVAL DRAWING

DISTRIBUTOR'S NAME:		P.O.#
VESTIL MANUFACTURING		X
DRAWN BY: CRM		W.O.#
DATE: 08/12/2010		X
REFERENCE: X	SCALE: 1:30	SALES: X
QUOTED LEAD TIME: X	QUOTE # X	FILE NAME:
		09-007-128