

SOLID DECK HARDWOOD DOLLIES - HDOS-2436-12

APPROX WEIGHT: 21.22 lbs.
 DOES NOT INCLUDE WEIGHT OF POWER OR PACKAGING!!!

*** ANY ADDITIONS, DELETIONS, OR OMISSIONS MUST BE CORRECTED ON THIS DRAWING AS THIS DRAWING WILL BE CONSIDERED ALL INCLUSIVE ***

ALL GRAPHICS PROVIDED ARE FOR REFERENCE ONLY. IF CERTAIN DIMENSIONS ARE CRITICAL PLEASE VERIFY THOSE DIMENSIONS WITH YOUR SALESPERSON

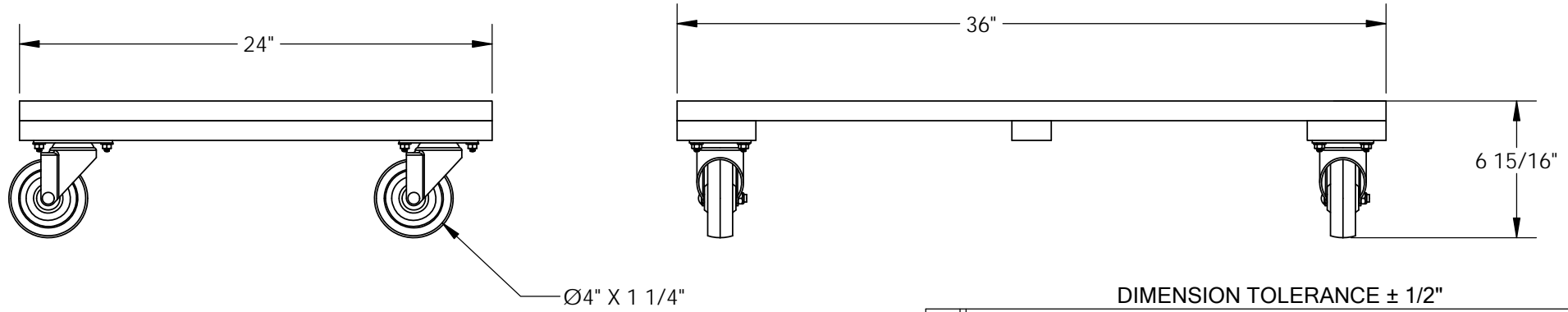
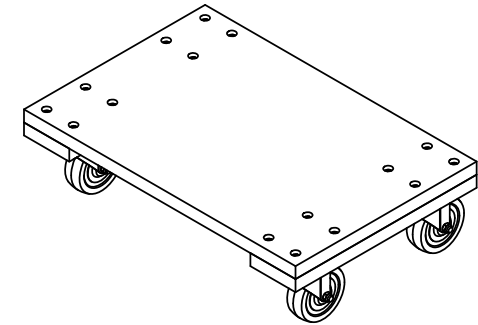

DIMENSION TOLERANCE ± 1/2"

STANDARD FEATURES

- MODEL NUMBER IS HDOS-2436-12
- OVERALL WIDTH IS 24"
- USABLE WIDTH IS 24"
- OVERALL LENGTH IS 36"
- USABLE LENGTH IS 36"
- OVERALL HEIGHT IS 6 15/16"
- MAX CAPACITY IS 1,200 LBS.
- 4X Ø4" X 1 1/4" HARD RUBBER SWIVEL CASTERS

SPECIAL FEATURES

NONE

APPROVAL	I, THE UNDERSIGNED, AGREE THAT THE PRODUCT AS REPRESENTED SATISFIES DESIGN AND DIMENSION REQUIREMENTS. I ALSO ACKNOWLEDGE MY DUTY TO CONFIRM PRODUCT AND INSTALLATION COMPLIANCE WITH ALL APPLICABLE FEDERAL, STATE AND LOCAL REGULATIONS AND STANDARDS.	
	ANY MODIFIED UNITS ARE NON-RETURNABLE	
	[] As drawn [] As marked	
	Signed: _____	Date: _____
Printed Name: _____		
<i>LEAD TIME WILL START UPON RECEIPT OF SIGNED APPROVAL DRAWING</i>		

FOR INTERNAL USE ONLY PROJECT SIGN OFF	
SALES	
ENG.	
FAB.	
POWER	

DISTRIBUTOR'S NAME:		P.O.#
VESTIL MANUFACTURING		X
W.O.#		X
DRAWN BY: CA	DATE: 2/6/2013	SALES: X
REFERENCE: X	SCALE: 1:8	FILE NAME:
QUOTED LEAD TIME: X	QUOTE # X	16-007-012