

# HEAVY DUTY PALLET RACK GUARD - HDPRG-42

APPROX WEIGHT: 91.86 lbs.  
 DOES NOT INCLUDE WEIGHT OF POWER OR PACKAGING!!!

\*\*\* ANY ADDITIONS, DELETIONS, OR OMISSIONS MUST BE CORRECTED ON THIS DRAWING AS THIS DRAWING WILL BE CONSIDERED ALL INCLUSIVE \*\*\*

ALL GRAPHICS PROVIDED ARE FOR REFERENCE ONLY. IF CERTAIN DIMENSIONS ARE CRITICAL PLEASE VERIFY THOSE DIMENSIONS WITH YOUR SALESPERSON

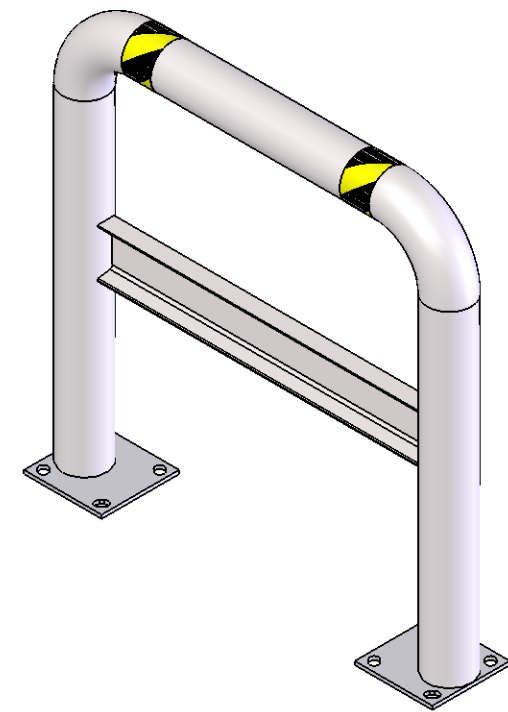
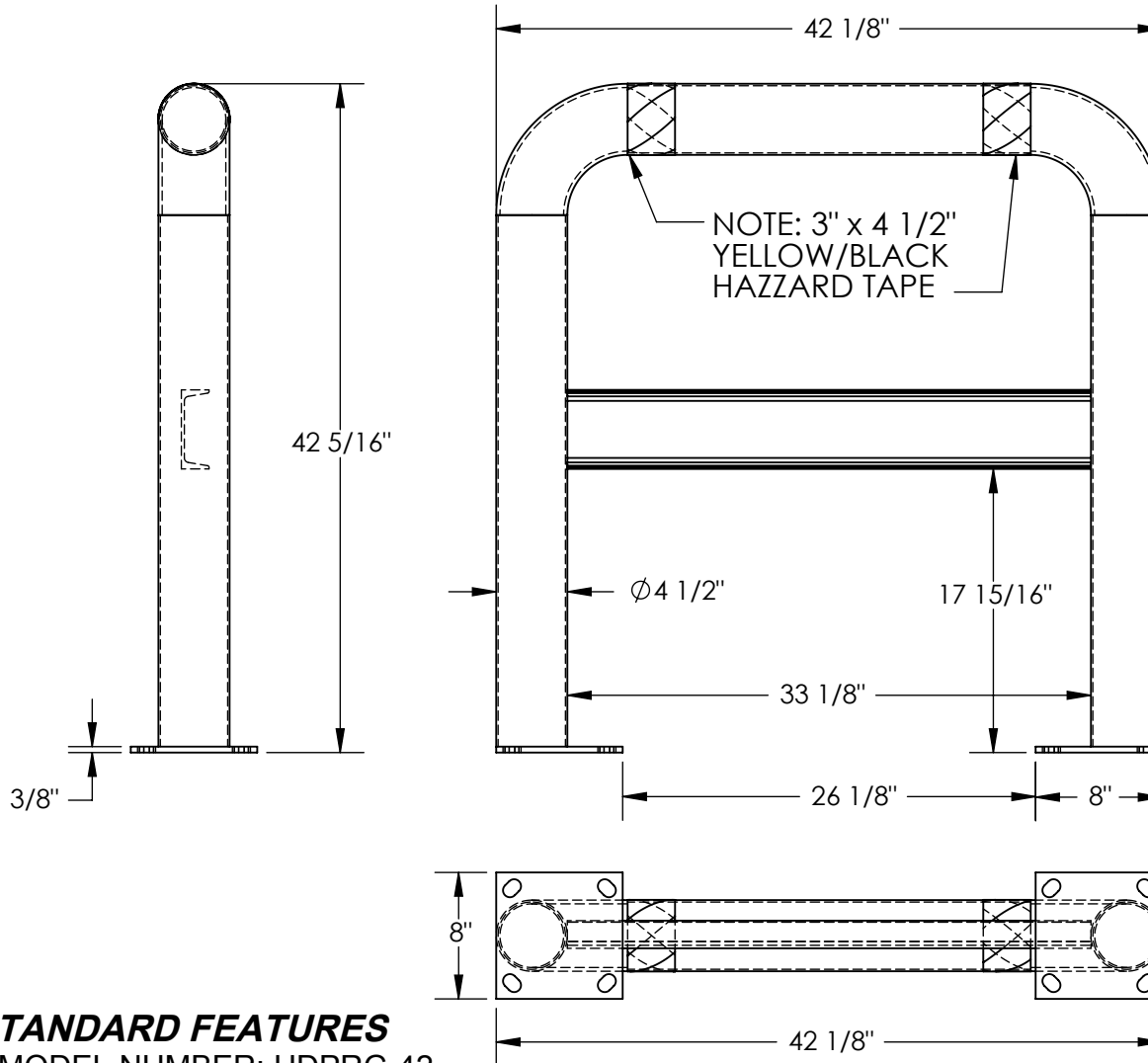

DIMENSION TOLERANCE ± 1/4"

## STANDARD FEATURES

- MODEL NUMBER: HDPRG-42
- MACHINE GUARD HEIGHT: 42 3/8"
- MACHINE GUARD WIDTH: 42 1/8"
- MACHINE GUARD LENGTH: 8"
- MACHINE GUARD PIPE DIA.: 4 1/2"
- COMES EQUIPPED WITH A LAG DOWN BRACKET
- PAINTED SAFETY YELLOW FOR HIGH VISIBILITY
- SAFETY BLACK AND YELLOW TAPE
- ALL STEEL CONSTRUCTION (ASTM A-36 MIN.)
- WITH WELDING TO MEET AWS
- WARNING: CHECK APPLICABLE STATE AND LOCAL LAWS FOR YOUR AREA

## SPECIAL FEATURES

NONE

**ALL SPECIAL UNITS ARE NON-RETURNABLE**

I, THE UNDERSIGNED, AGREE THAT THE PRODUCT AS REPRESENTED SATISFIES DESIGN AND DIMENSION REQUIREMENTS. I ALSO ACKNOWLEDGE MY DUTY TO CONFIRM PRODUCT AND INSTALLATION COMPLIANCE WITH ALL APPLICABLE FEDERAL, STATE AND LOCAL REGULATIONS AND STANDARDS.

**ALL SPECIAL UNITS ARE NON-RETURNABLE**

[ ] As drawn [ ] As marked

Signed: \_\_\_\_\_ Date: \_\_\_\_\_

LEAD TIME WILL START UPON RECEIPT OF SIGNED APPROVAL DRAWING

DISTRIBUTOR'S NAME:		P.O.#
VESTIL MANUFACTURING		X
DRAWN BY: CRM		W.O.#
DATE: 06/21/2010		X
REFERENCE: X	SCALE: 1:12	SALES: X
QUOTED LEAD TIME: X	QUOTE #	FILE NAME:
	X	23-007-376