

# LIFT-AND-DUMP HYDRAULIC DRUM DUMPERS - HLD-94-10-S

APPROX WEIGHT: 1124.93 lbs.  
 DOES NOT INCLUDE WEIGHT OF POWER OR PACKAGING!!!

\*\*\* ANY ADDITIONS, DELETIONS, OR OMISSIONS MUST BE CORRECTED ON THIS DRAWING AS THIS DRAWING WILL BE CONSIDERED ALL INCLUSIVE \*\*\*  
 ALL GRAPHICS PROVIDED ARE FOR REFERENCE ONLY. IF CERTAIN DIMENSIONS ARE CRITICAL PLEASE VERIFY THOSE DIMENSIONS WITH YOUR SALESPERSON

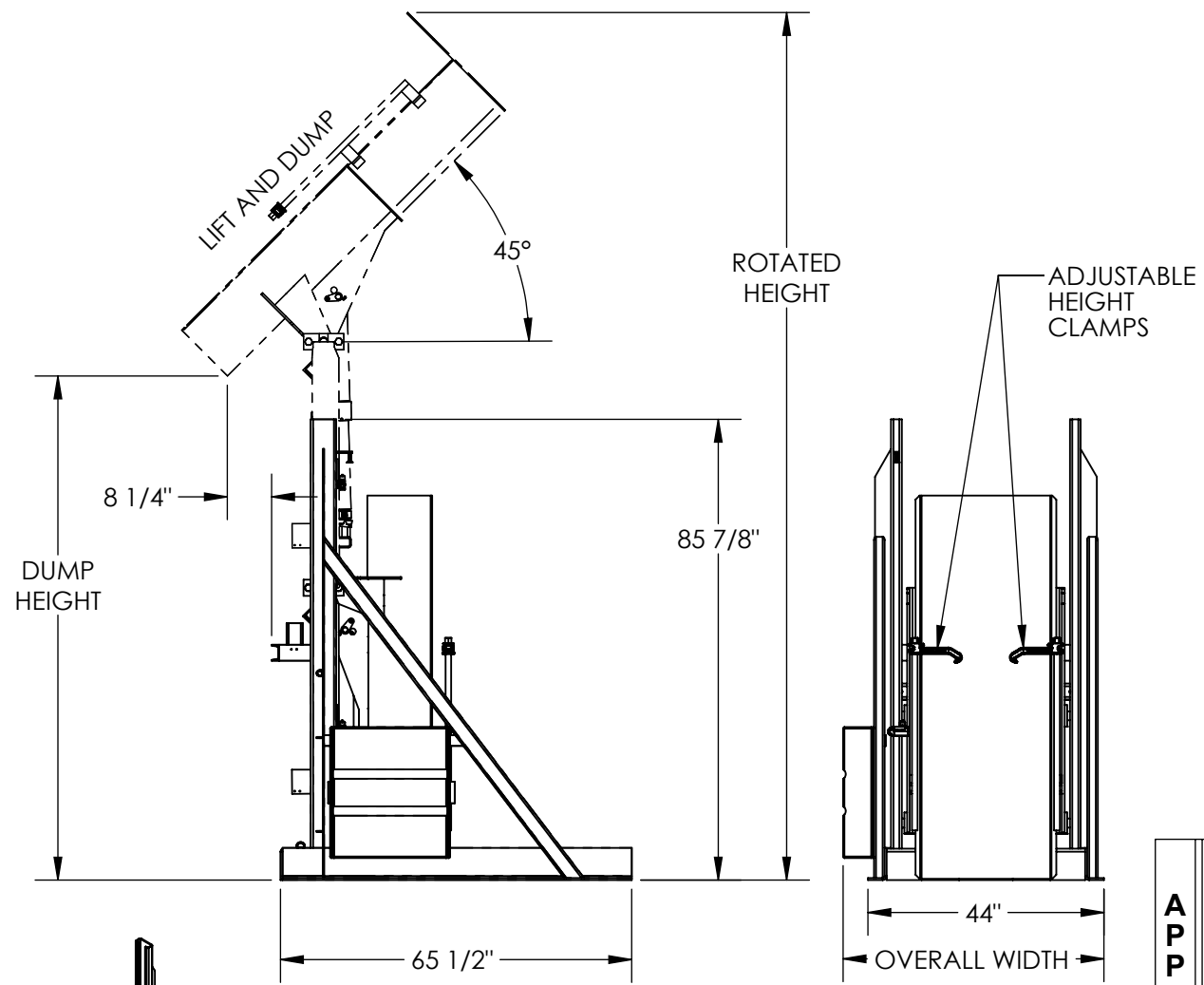

## STANDARD FEATURES

- MODEL NUMBER IS HLD-94-10-S
- LIFT AND DUMP DESIGN
- INDEPENDENT LIFT AND DUMP OPERATION
- MAX. DUMP HEIGHT IS 94"
- MIN. DUMP HEIGHT IS 48"
- OVERALL WIDTH IS 51"
- OVERALL LENGTH IS 65 1/2"
- LEVEL HEIGHT IS 85 7/8"
- ROTATED HEIGHT IS 163"
- DUMP ANGLE IS 45°
- UNIT IS STATIONARY
- MAX CAPACITY IS 1,000 LBS.
- WARNING:  
 CHECK LOCAL AND STATE CODES!  
 3000 PSI HYD. COMPONENT RATING

## SPECIAL FEATURES

NONE

DIMENSION TOLERANCE ± 1/4"

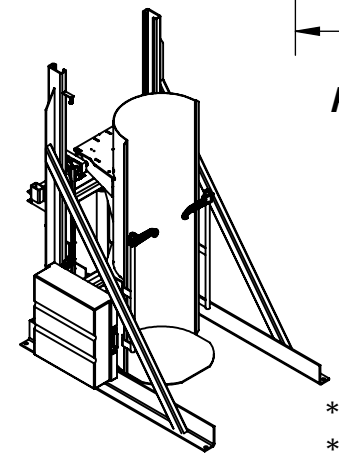

### PLEASE CIRCLE SPECIFICATIONS:

|                                      |  |  |  |
|--------------------------------------|--|--|--|
| POWER                                | <input checked="" type="checkbox"/> AC   | <input type="checkbox"/> * DC                | <input type="checkbox"/> * AIR/OIL                                   |
| MOTOR VOLTAGE                        | <input type="checkbox"/> 115             | <input type="checkbox"/> 208                 | <input type="checkbox"/> 230 <input checked="" type="checkbox"/> 460 |
| DEDICATED CIRCUIT REQUIRED           |  |  |  |
| MOTOR PHASE                          | <input type="checkbox"/> SINGLE          | <input checked="" type="checkbox"/> THREE    |  |
| CONTROL                              | <input checked="" type="checkbox"/> HAND | <input type="checkbox"/> * FOOT              |  |
| ~ ALL BATTERY CHARGERS ARE 115V AC ~ |  |  |  |
| * BATTERY CHRG.                      | <input type="checkbox"/> REMOTE          | <input checked="" type="checkbox"/> ON-BOARD |  |
| * CHRG. INDICATOR                    | <input checked="" type="checkbox"/> YES  | <input type="checkbox"/> NO                  |  |

\* AVAILABLE AT ADDITIONAL COST

|   |  |
|---|--|
| FOR INTERNAL USE ONLY<br>PROJECT SIGN OFF |  |
| SALES                                     |  |
| ENG.                                      |  |
| FAB.                                      |  |
| POWER                                     |  |

APPROVAL

I, THE UNDERSIGNED, AGREE THAT THE PRODUCT AS REPRESENTED SATISFIES DESIGN AND DIMENSION REQUIREMENTS. I ALSO ACKNOWLEDGE MY DUTY TO CONFIRM PRODUCT AND INSTALLATION COMPLIANCE WITH ALL APPLICABLE FEDERAL, STATE AND LOCAL REGULATIONS AND STANDARDS.

**ANY MODIFIED UNITS ARE NON-RETURNABLE**

[ ] As drawn      [ ] As marked

Signed: \_\_\_\_\_ Date: \_\_\_\_\_

Printed Name: \_\_\_\_\_

*LEAD TIME WILL START UPON RECEIPT OF SIGNED APPROVAL DRAWING*

|                      |             |            |
|----------------------|-------------|------------|
| DISTRIBUTOR'S NAME:  |             | P.O.#      |
| VESTIL MANUFACTURING |             | X          |
| DRAWN BY: CA         |             | W.O.#      |
| DATE: 09/02/2011     |             | X          |
| REFERENCE: X         | SCALE: 1:34 | SALES: X   |
| QUOTED LEAD TIME: X  | QUOTE #     | FILE NAME: |
|                      | X           | 09-007-099 |