

LONG DECK CART - LDLT-3060-4

APPROX WEIGHT: 471.70 lbs.
DOES NOT INCLUDE WEIGHT OF POWER OR PACKAGING!!!

*** ANY ADDITIONS, DELETIONS, OR OMISSIONS MUST BE CORRECTED ON THIS DRAWING AS THIS DRAWING WILL BE CONSIDERED ALL INCLUSIVE ***

ALL GRAPHICS PROVIDED ARE FOR REFERENCE ONLY. IF CERTAIN DIMENSIONS ARE CRITICAL PLEASE VERIFY THOSE DIMENSIONS WITH YOUR SALESPERSON

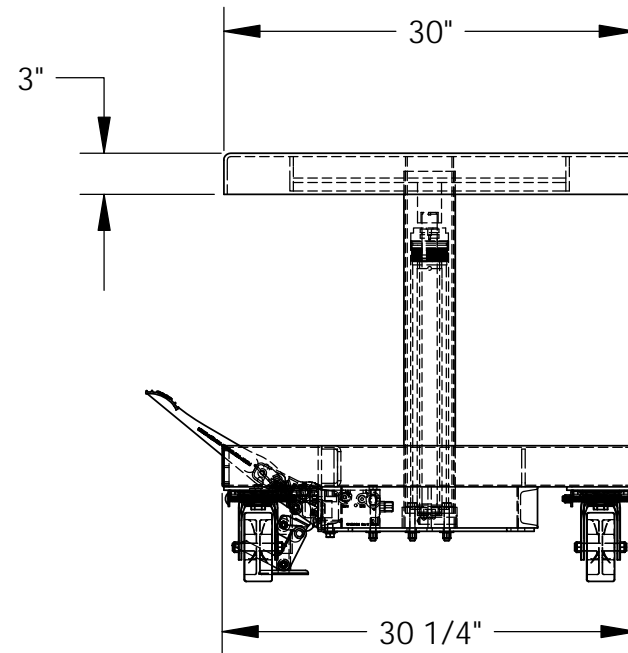
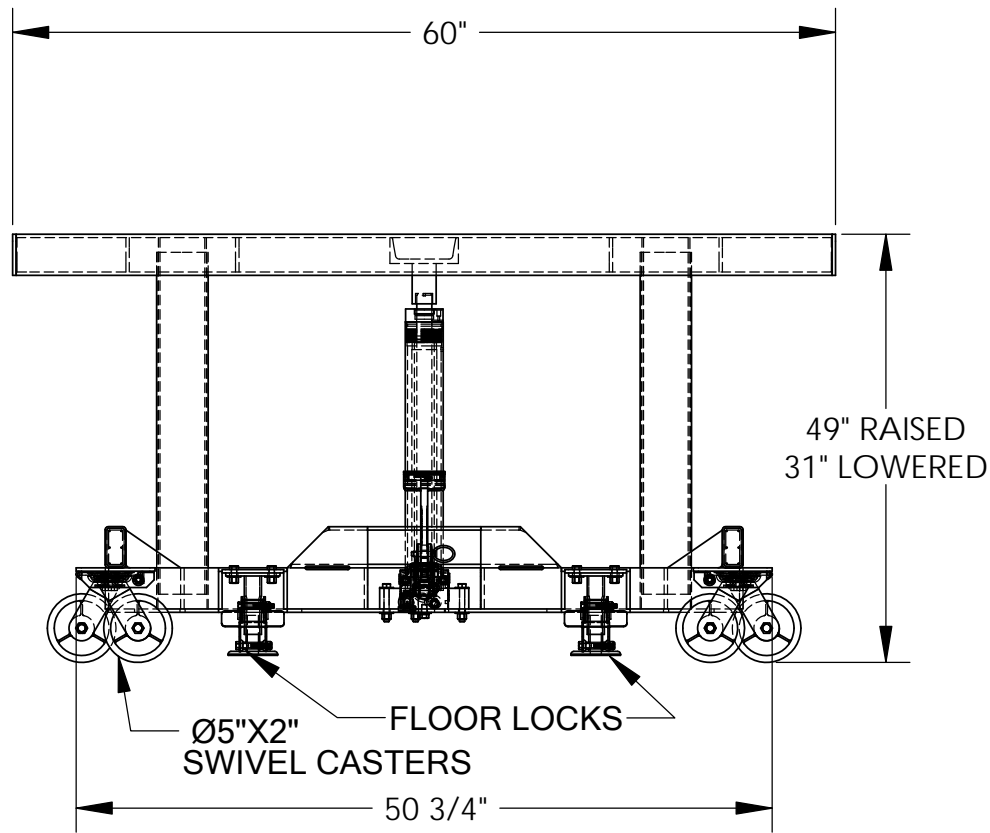

DIMENSION TOLERANCE ± 1/4"

STANDARD FEATURES

- MODEL NUMBER IS LDLT-3060-4
- CAPACITY IS 4000 LBS. (EVENLY DISTRIBUTED)
- PLATFORM WIDTH IS 30"
- FRAME WIDTH IS 30 1/4"
- PLATFORM LENGTH IS 60"
- FRAME LENGTH IS 50 3/4"
- PLATFORM RAISED HEIGHT IS 49"
- PLATFORM LOWERED HEIGHT IS 31"
- FOUR SWIVEL 5" X 2" POLY-ON-STEEL CASTERS
- DUAL FLOOR LOCKS
- MANUAL FOOT PUMP OPERATION
- LIQUID PAINTED BLUE FINISH

SPECIAL FEATURES

NONE

APPROVAL

I, THE UNDERSIGNED, AGREE THAT THE PRODUCT AS REPRESENTED SATISFIES DESIGN AND DIMENSION REQUIREMENTS. I ALSO ACKNOWLEDGE MY DUTY TO CONFIRM PRODUCT AND INSTALLATION COMPLIANCE WITH ALL APPLICABLE FEDERAL, STATE AND LOCAL REGULATIONS AND STANDARDS.

ANY MODIFIED UNITS ARE NON-RETURNABLE

[] As drawn [] As marked

Signed: _____ Date: _____

Printed Name: _____

LEAD TIME WILL START UPON RECEIPT OF SIGNED APPROVAL DRAWING

FOR INTERNAL USE ONLY PROJECT SIGN OFF	
SALES	
ENG.	
FAB.	
POWER	

DISTRIBUTOR'S NAME:		P.O.#
VESTIL MANUFACTURING		X
DRAWN BY: RAL		DATE: 06/02/16
REFERENCE: X		SCALE: 1:14
QUOTED LEAD TIME: X		QUOTE # X
		W.O.# X
		SALES: X
		FILE NAME: 21-007-127