

LONG DECK CART - LDLT-3072-4

APPROX WEIGHT: 527.06 lbs.
DOES NOT INCLUDE WEIGHT OF POWER OR PACKAGING!!!

*** ANY ADDITIONS, DELETIONS, OR OMISSIONS MUST BE CORRECTED ON THIS DRAWING AS THIS DRAWING WILL BE CONSIDERED ALL INCLUSIVE ***

ALL GRAPHICS PROVIDED ARE FOR REFERENCE ONLY. IF CERTAIN DIMENSIONS ARE CRITICAL PLEASE VERIFY THOSE DIMENSIONS WITH YOUR SALESPERSON

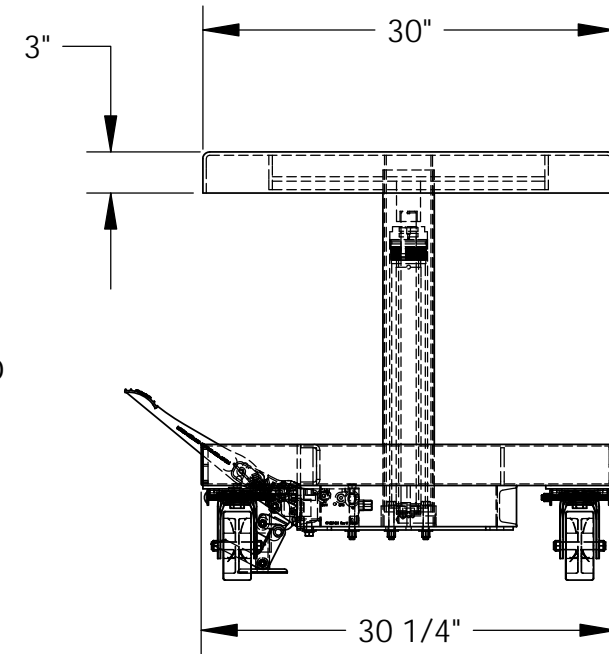
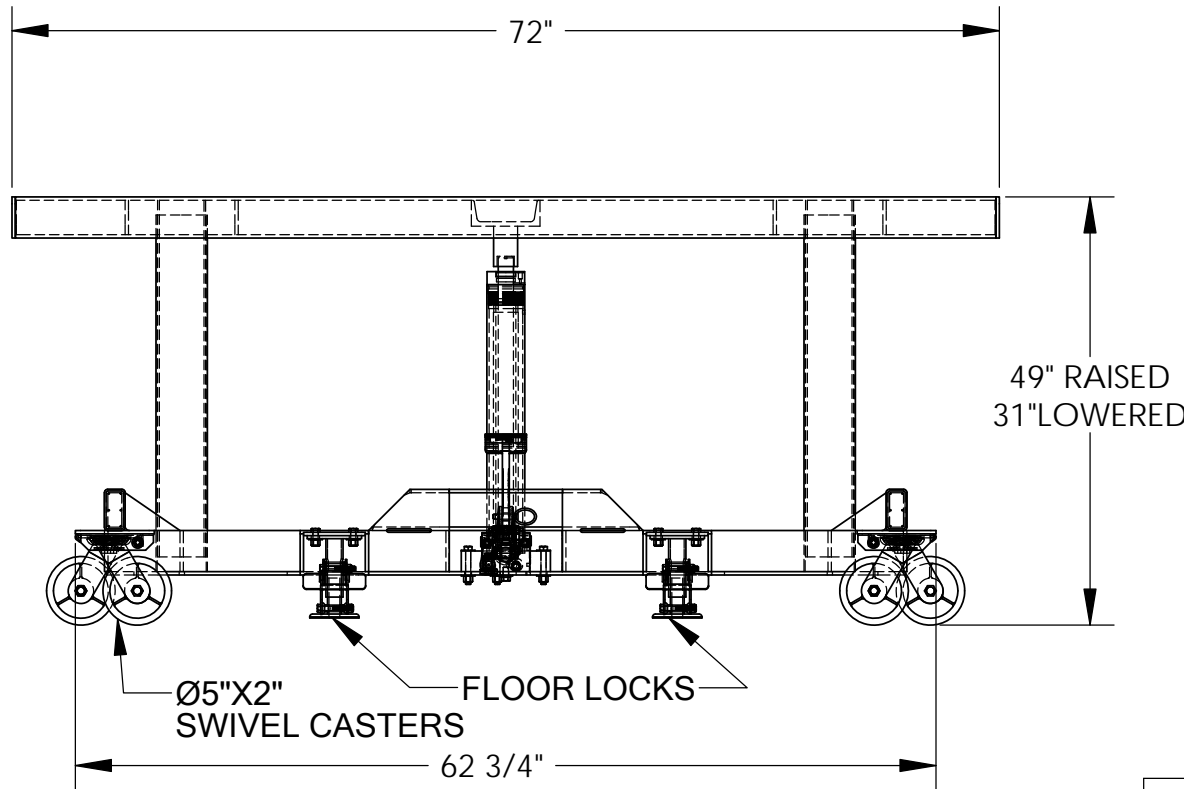

DIMENSION TOLERANCE ± 1/4"

STANDARD FEATURES

- MODEL NUMBER IS LDLT-3072-4
- CAPACITY IS 4000 LBS. (EVENLY DISTRIBUTED)
- PLATFORM WIDTH IS 30"
- FRAME WIDTH IS 30 1/4"
- PLATFORM LENGTH IS 72"
- FRAME LENGTH IS 62 3/4"
- PLATFORM RAISED HEIGHT IS 49"
- PLATFORM LOWERED HEIGHT IS 31"
- FOUR SWIVEL 5" X 2" POLY-ON-STEEL CASTERS
- DUAL FLOOR LOCKS
- MANUAL FOOT PUMP OPERATION
- LIQUID PAINTED BLUE FINISH

SPECIAL FEATURES

NONE

| | | |
|--|--|-------------|
| APPROVAL | I, THE UNDERSIGNED, AGREE THAT THE PRODUCT AS REPRESENTED SATISFIES DESIGN AND DIMENSION REQUIREMENTS. I ALSO ACKNOWLEDGE MY DUTY TO CONFIRM PRODUCT AND INSTALLATION COMPLIANCE WITH ALL APPLICABLE FEDERAL, STATE AND LOCAL REGULATIONS AND STANDARDS. | |
| | ANY MODIFIED UNITS ARE NON-RETURNABLE | |
| | [] As drawn [] As marked | |
| | Signed: _____ | Date: _____ |
| Printed Name: _____ | | |
| LEAD TIME WILL START UPON RECEIPT OF SIGNED APPROVAL DRAWING | | |

| | |
|---|--|
| FOR INTERNAL USE ONLY PROJECT SIGN OFF | |
| SALES | |
| ENG. | |
| FAB. | |
| POWER | |

| | | |
|----------------------|---------------|------------|
| DISTRIBUTOR'S NAME: | | P.O.# |
| VESTIL MANUFACTURING | | X |
| DRAWN BY: RAL | DATE: 6/01/16 | W.O.# |
| REFERENCE: X | SCALE: 1:14 | X |
| QUOTED LEAD TIME: X | QUOTE # | FILE NAME: |
| | X | 21-007-126 |