

ADJUSTABLE PANEL DOLLY - PLDL-HD-4-8GFN

APPROX WEIGHT: 41.12 lbs.
DOES NOT INCLUDE WEIGHT OF POWER OR PACKAGING!!!

*** ANY ADDITIONS, DELETIONS, OR OMISSIONS MUST BE CORRECTED ON THIS DRAWING AS THIS DRAWING WILL BE CONSIDERED ALL INCLUSIVE ***

ALL GRAPHICS PROVIDED ARE FOR REFERENCE ONLY. IF CERTAIN DIMENSIONS ARE CRITICAL PLEASE VERIFY THOSE DIMENSIONS WITH YOUR SALESPERSON

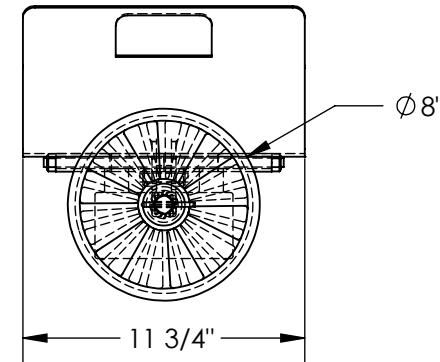
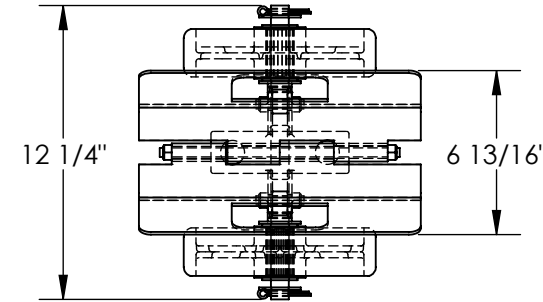
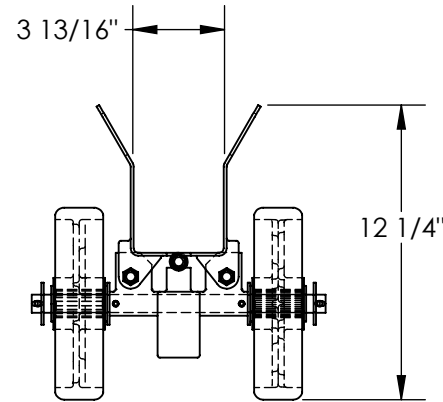

DIMENSION TOLERANCE ± 1/4"

STANDARD FEATURES

- MODEL NUMBER IS PLDL-HD-4-8GFN
- CAPACITY IS: 1,500 LBS.
- OVERALL WIDTH IS: 12 1/4"
- MAX. USABLE WIDTH IS 3 13/16"
- OVERALL LENGTH IS: 11 3/4"
- OVERALL HEIGHT IS: 12 1/4"
- DOLLY AUTOMATICALLY CLAMPS WHEN WEIGHT IS APPLIED
- STRAP (NOT INCLUDED) CAN BE HOOKED TO HAND SLOTS
- USES TWO 8" GLASS-FILLED NYLON WHEELS

SPECIAL FEATURES

NONE

APPROVAL	I, THE UNDERSIGNED, AGREE THAT THE PRODUCT AS REPRESENTED SATISFIES DESIGN AND DIMENSION REQUIREMENTS. I ALSO ACKNOWLEDGE MY DUTY TO CONFIRM PRODUCT AND INSTALLATION COMPLIANCE WITH ALL APPLICABLE FEDERAL, STATE AND LOCAL REGULATIONS AND STANDARDS.	
	UNITS REQUIRING APPROVAL DRAWINGS OR MODIFIED ARE NON-RETURNABLE	
	[] As drawn [] As marked	
	Signed: _____ Date: _____	
Printed Name: _____		
LEAD TIME WILL START UPON RECEIPT OF SIGNED APPROVAL DRAWING		

FOR INTERNAL USE ONLY PROJECT SIGN OFF	
SALES	
ENG.	
FAB.	
POWER	

DISTRIBUTOR'S NAME:		P.O.#
VESTIL MANUFACTURING		X
DRAWN BY: TAL		W.O.#
DATE: 9/4/2020		X
REFERENCE: X	SCALE: 1:8	SALES: X
QUOTED LEAD TIME: X	QUOTE #	FILE NAME:
	X	16-007-514-001