

BASKET AND SKID STACKER - PMSS-50-DC

APPROX WEIGHT: 1011.48 lbs.
DOES NOT INCLUDE WEIGHT OF POWER OR PACKAGING!!!

*** ANY ADDITIONS, DELETIONS, OR OMISSIONS MUST BE CORRECTED ON THIS DRAWING AS THIS DRAWING WILL BE CONSIDERED ALL INCLUSIVE ***
ALL GRAPHICS PROVIDED ARE FOR REFERENCE ONLY. IF CERTAIN DIMENSIONS ARE CRITICAL PLEASE VERIFY THOSE DIMENSIONS WITH YOUR SALESPERSON

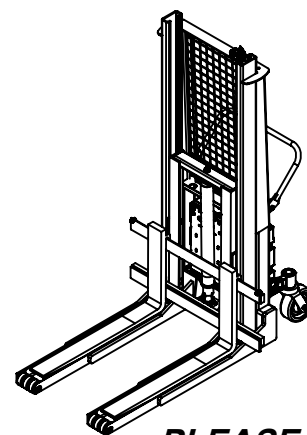
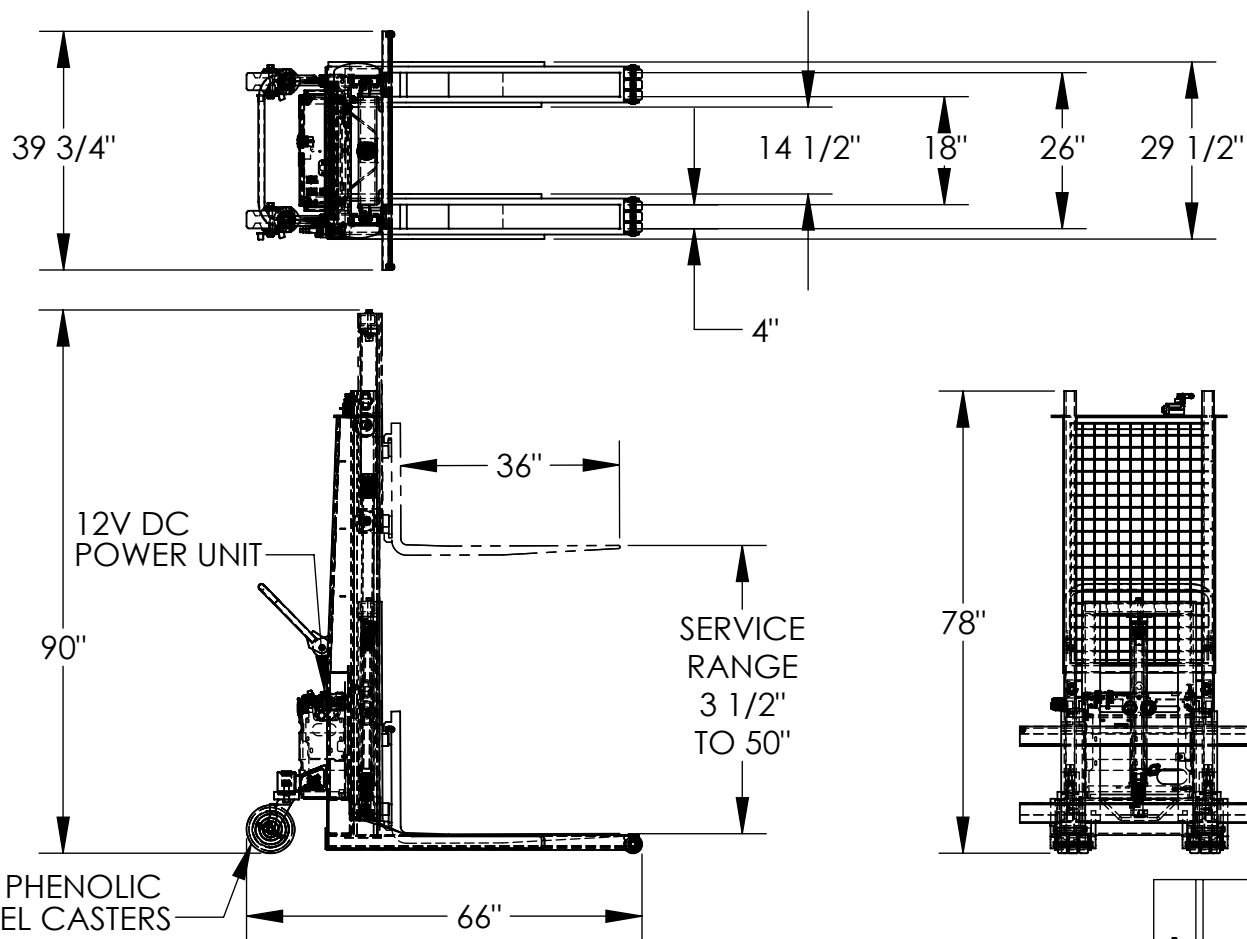

PLEASE CIRCLE SPECIFICATIONS:

POWER	<input type="checkbox"/> AC	<input checked="" type="checkbox"/> DC (12V)	<input type="checkbox"/> *AIR/OIL	
MOTOR VOLTAGE	<input type="checkbox"/> 115	<input type="checkbox"/> 208	<input type="checkbox"/> 230	<input type="checkbox"/> 460
DEDICATED CIRCUIT REQUIRED				
MOTOR PHASE	<input type="checkbox"/> SINGLE		<input type="checkbox"/> THREE	
CONTROL	<input checked="" type="checkbox"/> HAND	<input type="checkbox"/> * FOOT		
~ ALL BATTERY CHARGERS ARE 115V AC ~				
BATTERY CHR.G.	<input type="checkbox"/> REMOTE	<input checked="" type="checkbox"/> ON-BOARD		
* CHR.G. INDICATOR	<input type="checkbox"/> YES	<input type="checkbox"/> NO		

* AVAILABLE AT ADDITIONAL COST

DIMENSION TOLERANCE ± 1/4"

STANDARD FEATURES

- MODEL NUMBER IS PMSS-50-DC
- CAPACITY IS 4,000LBS
- OVERALL WIDTH 39 3/4"
- OUTSIDE LEG WIDTH IS 29 1/2"
- OVERALL LENGTH IS 66"
- OVERALL LOWERED HEIGHT IS 78"
- OVERALL RAISED HEIGHT IS 90"
- FORK SIZE IS 1 1/2" THICK X 4" WIDE X 36" LONG
- LOWERED FORK HEIGHT IS 3 1/2"
- RAISED FORK HEIGHT IS 50"
- 8 X 3 PHENOLIC SWIVEL CASTERS IN REAR
- 12V DC POWER UNIT
- CONTROL PENDANT W/ 8' CORD NOT SHOWN
- DURABLE LIQUID PAINT BLUE FINISH

SPECIAL FEATURES

NONE

APPROVAL

I, THE UNDERSIGNED, AGREE THAT THE PRODUCT AS REPRESENTED SATISFIES DESIGN AND DIMENSION REQUIREMENTS. I ALSO ACKNOWLEDGE MY DUTY TO CONFIRM PRODUCT AND INSTALLATION COMPLIANCE WITH ALL APPLICABLE FEDERAL, STATE AND LOCAL REGULATIONS AND STANDARDS.

ANY MODIFIED UNITS ARE NON-RETURNABLE

[] As drawn [] As marked

Signed: _____ Date: _____

Printed Name: _____

LEAD TIME WILL START UPON RECEIPT OF SIGNED APPROVAL DRAWING

FOR INTERNAL USE ONLY
PROJECT SIGN OFF

SALES	
ENG.	
FAB.	
POWER	

DISTRIBUTOR'S NAME:		P.O.#
VESTIL MANUFACTURING		X
DRAWN BY: A.FORD		W.O.#
DATE: 8/3/2007		X
REFERENCE: X	SCALE: 1:32	SALES: X
QUOTED LEAD TIME: X	QUOTE #	FILE NAME:
	X	15-007-102