

REEL RACK - RERC-438

APPROX WEIGHT: 193.36 lbs.
 DOES NOT INCLUDE WEIGHT OF POWER OR PACKAGING!!!

*** ANY ADDITIONS, DELETIONS, OR OMISSIONS MUST BE CORRECTED ON THIS DRAWING AS THIS DRAWING WILL BE CONSIDERED ALL INCLUSIVE ***

ALL GRAPHICS PROVIDED ARE FOR REFERENCE ONLY. IF CERTAIN DIMENSIONS ARE CRITICAL PLEASE VERIFY THOSE DIMENSIONS WITH YOUR SALESPERSON

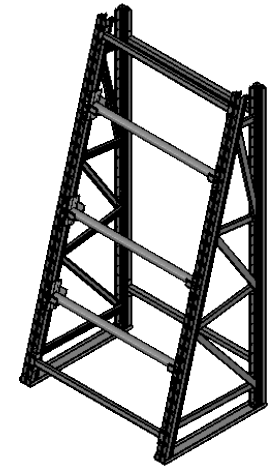
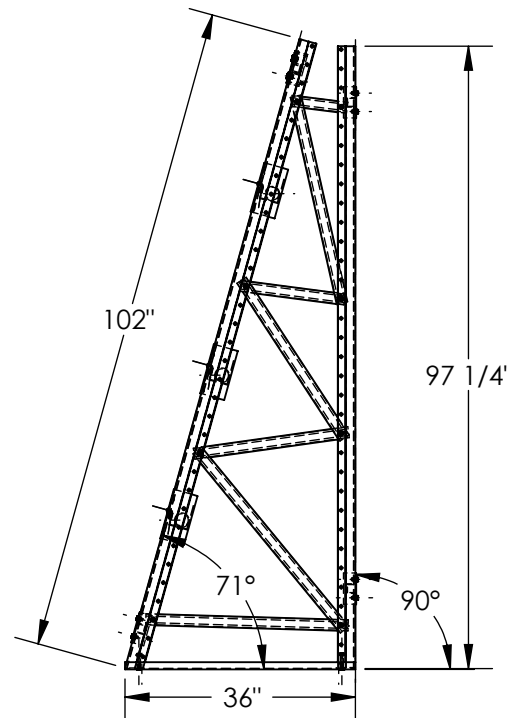
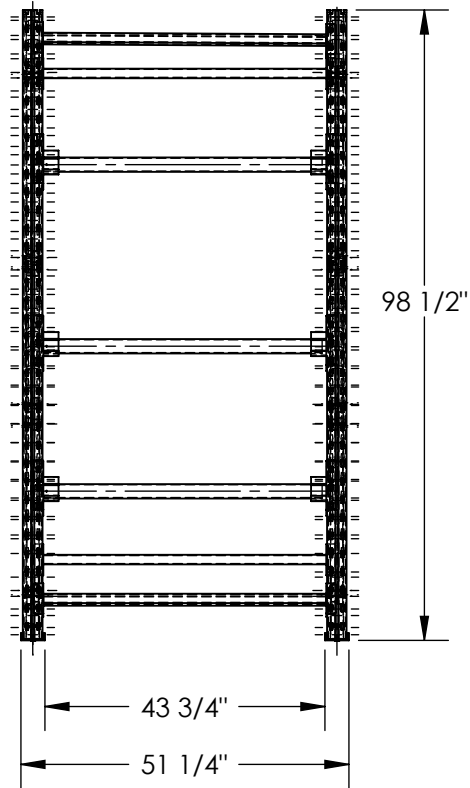

DIMENSION TOLERANCE ± 1/2"

FOR INTERNAL USE ONLY PROJECT SIGN OFF	
SALES	
ENG.	
FAB.	
POWER	

APPROVAL

I, THE UNDERSIGNED, AGREE THAT THE PRODUCT AS REPRESENTED SATISFIES DESIGN AND DIMENSION REQUIREMENTS. I ALSO ACKNOWLEDGE MY DUTY TO CONFIRM PRODUCT AND INSTALLATION COMPLIANCE WITH ALL APPLICABLE FEDERAL, STATE AND LOCAL REGULATIONS AND STANDARDS.

ANY MODIFIED UNITS ARE NON-RETURNABLE

As drawn As marked

Signed: _____ Date: _____

Printed Name: _____

LEAD TIME WILL START UPON RECEIPT OF SIGNED APPROVAL DRAWING

STANDARD FEATURES

- MODEL NUMBER IS RERC-438
- OVERALL WIDTH IS 51 1/4"
- OVERALL LENGTH IS 36"
- OVERALL HEIGHT IS 98 1/2"
- MAX CAPACITY IS 6000 LBS. EVENLY DISTRIBUTED
- AXLES AND BRACKETS ARE TOUGH BAKED IN POWDER COAT ORANGE FINISH
- FRAME IS TOUGH BAKED IN POWDER COAT WHITE FINISH

BOLT TOGETHER ASSEMBLY REQUIRED. ASSEMBLY HARDWARE INCLUDED
 RERC-438 INCLUDES THREE AXLES
 ALL AXLES ARE ADJUSTABLE ALONG RACK LEGS

SPECIAL FEATURES

NONE

DISTRIBUTOR'S NAME:		P.O.#
VESTIL MANUFACTURING		X
DRAWN BY: CA		W.O.#
DATE: 5/27/2014		X
REFERENCE: X	SCALE: 1:30	SALES: X
QUOTED LEAD TIME: X	QUOTE #	FILE NAME:
	X	31-007-192