

# FOOT PUMP HYDRAULIC SCISSOR LIFT TABLE - SCTAB-2500-2040-FP

APPROX WEIGHT: 290.86 lbs.  
 DOES NOT INCLUDE WEIGHT OF POWER OR PACKAGING!!!

\*\*\* ANY ADDITIONS, DELETIONS, OR OMISSIONS MUST BE CORRECTED ON THIS DRAWING AS THIS DRAWING WILL BE CONSIDERED ALL INCLUSIVE \*\*\*  
 ALL GRAPHICS PROVIDED ARE FOR REFERENCE ONLY. IF CERTAIN DIMENSIONS ARE CRITICAL PLEASE VERIFY THOSE DIMENSIONS WITH YOUR SALESPERSON

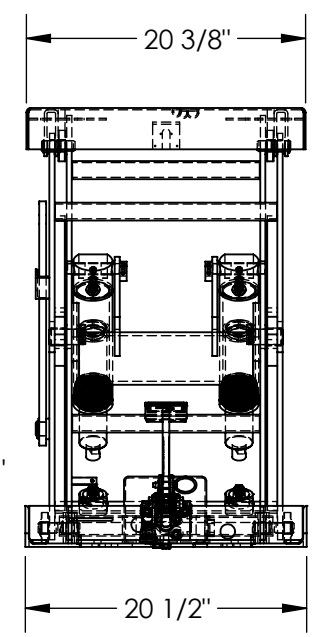
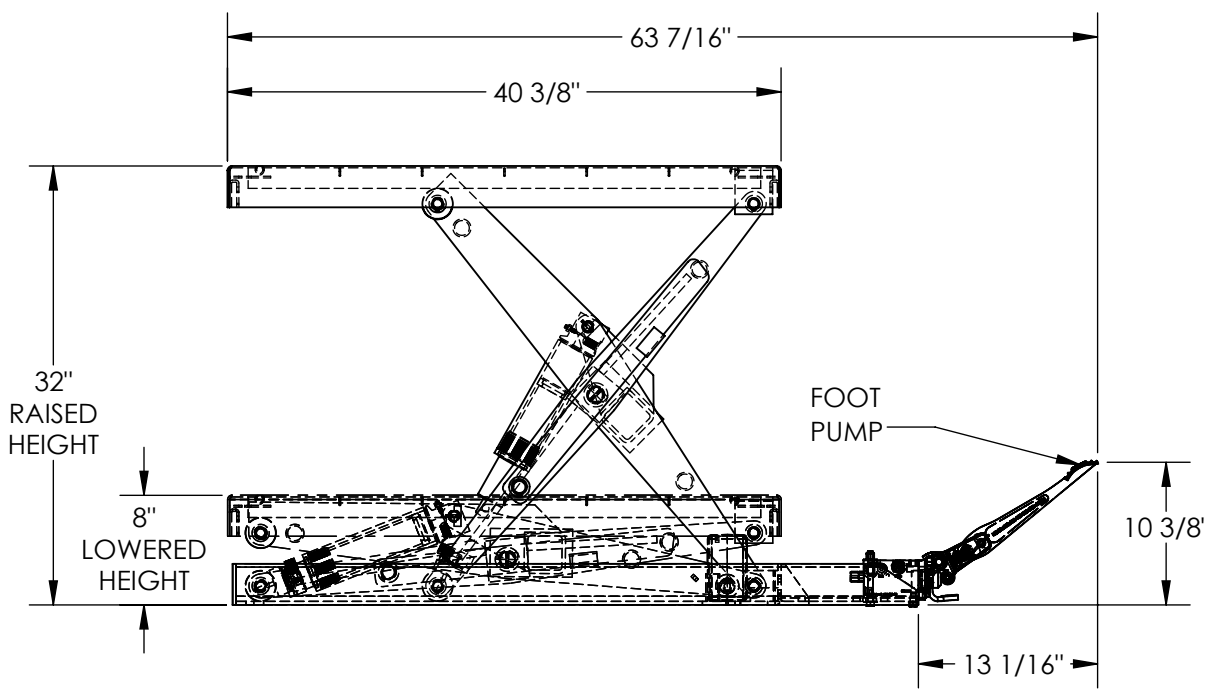

DECK TOLERANCE  $\pm 1/2"$   
 TABLE HEIGHT TOLERANCES  $\pm 1/2"$   
 DECK FLATNESS  $\pm 1/4"$

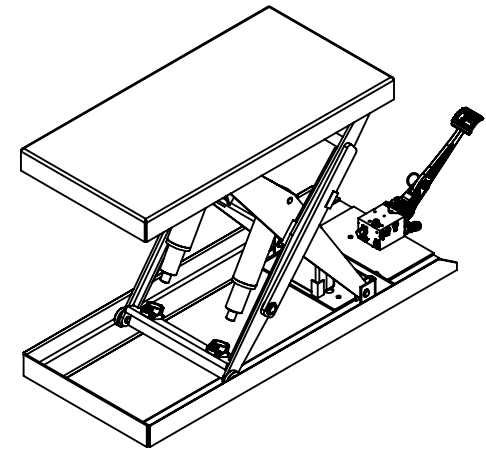

## STANDARD FEATURES

- MODEL NUMBER IS SCTAB-2500-2040-FP
- DECK WIDTH: 20 3/8"
- DECK LENGTH: 40 3/8"
- RAISED HEIGHT: 32"
- LOWERED HEIGHT: 8"
- TABLE CAPACITY (EVENLY DISTRIBUTED)
- MAX CAPACITY IS 2,500 LBS
- SAFETY MAINTENANCE PROPS, DISPLACEMENT STYLE CYLINDERS INSTALLED ROD DOWN
- EMERGENCY SAFETY STOP HYDRAULIC FUSES
- TWO SPEED AUTO SHIFTING MANUAL FOOT PUMP
- NUMBER OF PUMPS TO RAISE TABLE
- LOW PRESSURE: 36
- HIGH PRESSURE: 100
- DURABLE LIQUID PAINT BLUE FINISH

## SPECIAL FEATURES

NONE

DIMENSION TOLERANCE  $\pm 1/4"$

APPROVAL	I, THE UNDERSIGNED, AGREE THAT THE PRODUCT AS REPRESENTED SATISFIES DESIGN AND DIMENSION REQUIREMENTS. I ALSO ACKNOWLEDGE MY DUTY TO CONFIRM PRODUCT AND INSTALLATION COMPLIANCE WITH ALL APPLICABLE FEDERAL, STATE AND LOCAL REGULATIONS AND STANDARDS.	
	ANY MODIFIED UNITS ARE NON-RETURNABLE	
	[ ] As drawn      [ ] As marked	
Signed: _____		Date: _____
Printed Name: _____		
LEAD TIME WILL START UPON RECEIPT OF SIGNED APPROVAL DRAWING		

FOR INTERNAL USE ONLY PROJECT SIGN OFF	
SALES	
ENG.	
FAB.	
POWER	

DISTRIBUTOR'S NAME:		P.O.#
VESTIL MANUFACTURING		X
DRAWN BY: CA	DATE: 10/10/2017	W.O.#
REFERENCE: X	SCALE: 1:14	X
QUOTED LEAD TIME: X	QUOTE #	FILE NAME:
	X	01-007-352