

NARROW MAST STACKER W/ POWERED LIFT - SLNM-118-FF

APPROX WEIGHT: 720 lbs.
DOES NOT INCLUDE WEIGHT OF
POWER OR PACKAGING!!!

ANY ADDITIONS, DELETIONS, OR OMISSIONS MUST BE CORRECTED ON THIS DRAWING AS THIS DRAWING WILL BE CONSIDERED ALL INCLUSIVE

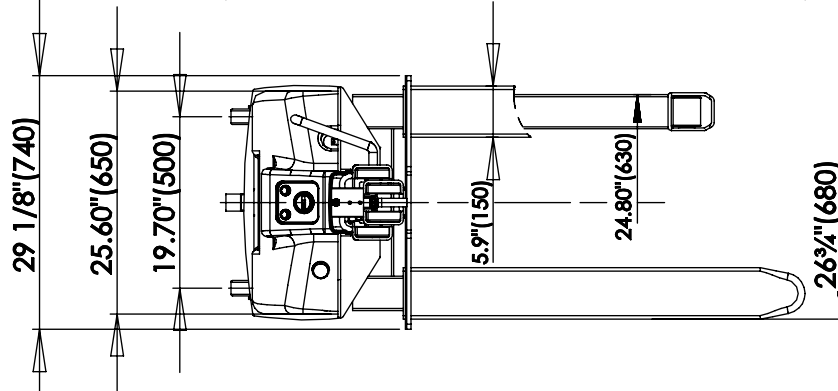
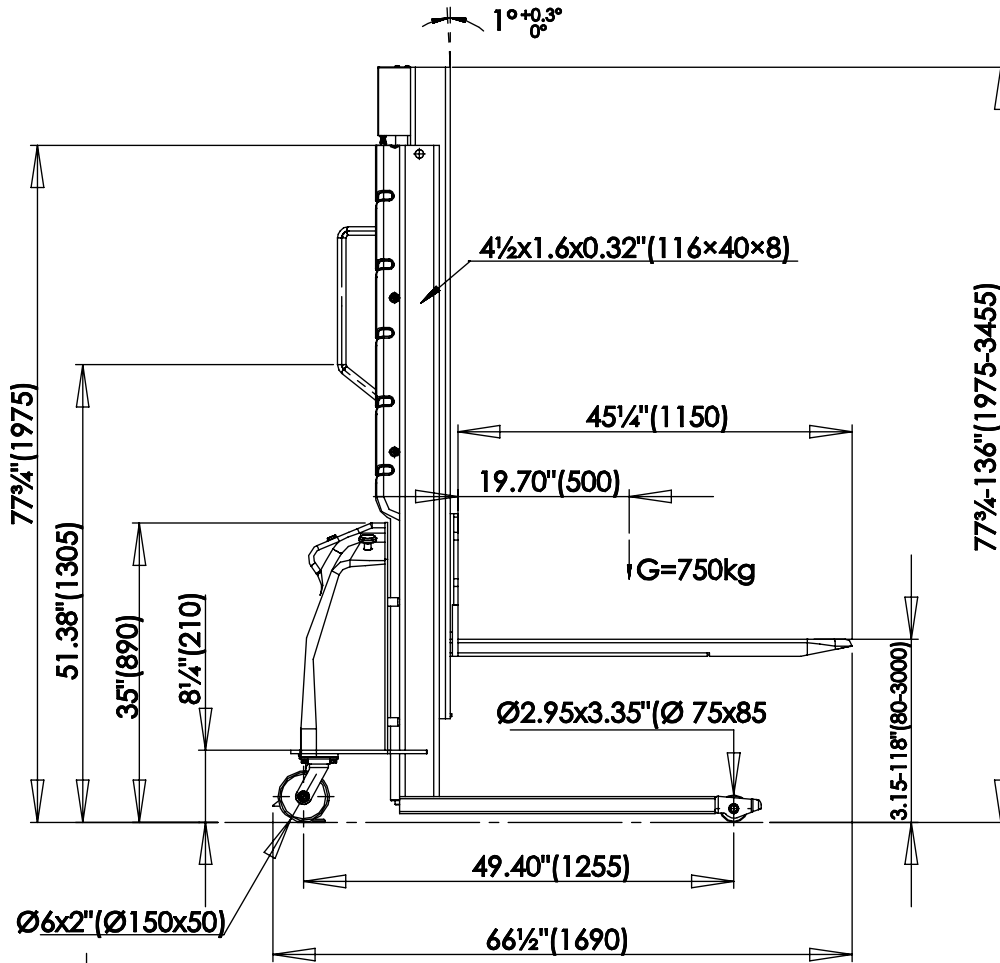

FOR INTERNAL USE ONLY
PROJECT SIGN OFF

SALES	
ENG.	
FAB.	
POWER	

ALL GRAPHICS PROVIDED ARE FOR REFERENCE ONLY. IF CERTAIN DIMENSIONS ARE CRITICAL PLEASE VERIFY THOSE DIMENSIONS WITH YOUR SALESPERSON

STANDARD FEATURES

- MODEL #: SLNM-118-FF
- CAPACITY (UDL) 0-63": 1,500 lbs (680 kg)
- CAPACITY (UDL) 63-118": 1,000 lbs (450 kg)
- LIFT HEIGHT: 118" (3000mm)
- LOWERED HEIGHT: 3.15" (80mm)
- FIXED FORKS OVER FIXED LEGS
- OVERALL MAST HEIGHT 77 3/4"
- LIFT MOTOR: DC 12V/1.3 Kw
- BATTERY CHARGER: 12V/6amp
- RAISE TIME LOADED: 5.9"/s
- RAISE TIME UNLOADED: 2.95"/s
- DOWN TIME LOADED: 4"/s
- DOWN TIME UNLOADED: 3.15"/s
- TOUGH BAKED IN POWDER COATED BLACK & YELLOW FINISH

APPROVAL

I, THE UNDERSIGNED, AGREE THAT THE PRODUCT AS REPRESENTED SATISFIES DESIGN AND DIMENSION REQUIREMENTS. I ALSO ACKNOWLEDGE MY DUTY TO CONFIRM PRODUCT AND INSTALLATION COMPLIANCE WITH ALL APPLICABLE FEDERAL, STATE AND LOCAL REGULATIONS AND STANDARDS.
UNITS REQUIRING APPROVAL DRAWINGS OR MODIFIED ARE NON-RETURNABLE
[] As drawn [] As marked

Signed: _____ Date: _____

Printed Name: _____

LEAD TIME WILL START UPON RECEIPT OF SIGNED APPROVAL DRAWING

DISTRIBUTOR'S NAME:		P.O.#
VESTIL MANUFACTURING		X
DRAWN BY: TM		W.O.#
DATE: 2/22/2017		X
REFERENCE: X	SCALE: 1:2	SALES: X
QUOTED LEAD TIME: X	QUOTE #	FILE NAME:
	X	SLNM-118-FF