

# STEEL HAND TRUCK - SPHT-660-BSG

APPROX WEIGHT: 48.99 lbs.  
DOES NOT INCLUDE WEIGHT OF POWER OR PACKAGING!!!

\*\*\*ANY ADDITIONS, DELETIONS, OR OMISSIONS MUST BE CORRECTED ON THIS DRAWING AS THIS DRAWING WILL BE CONSIDERED ALL INCLUSIVE\*\*\*

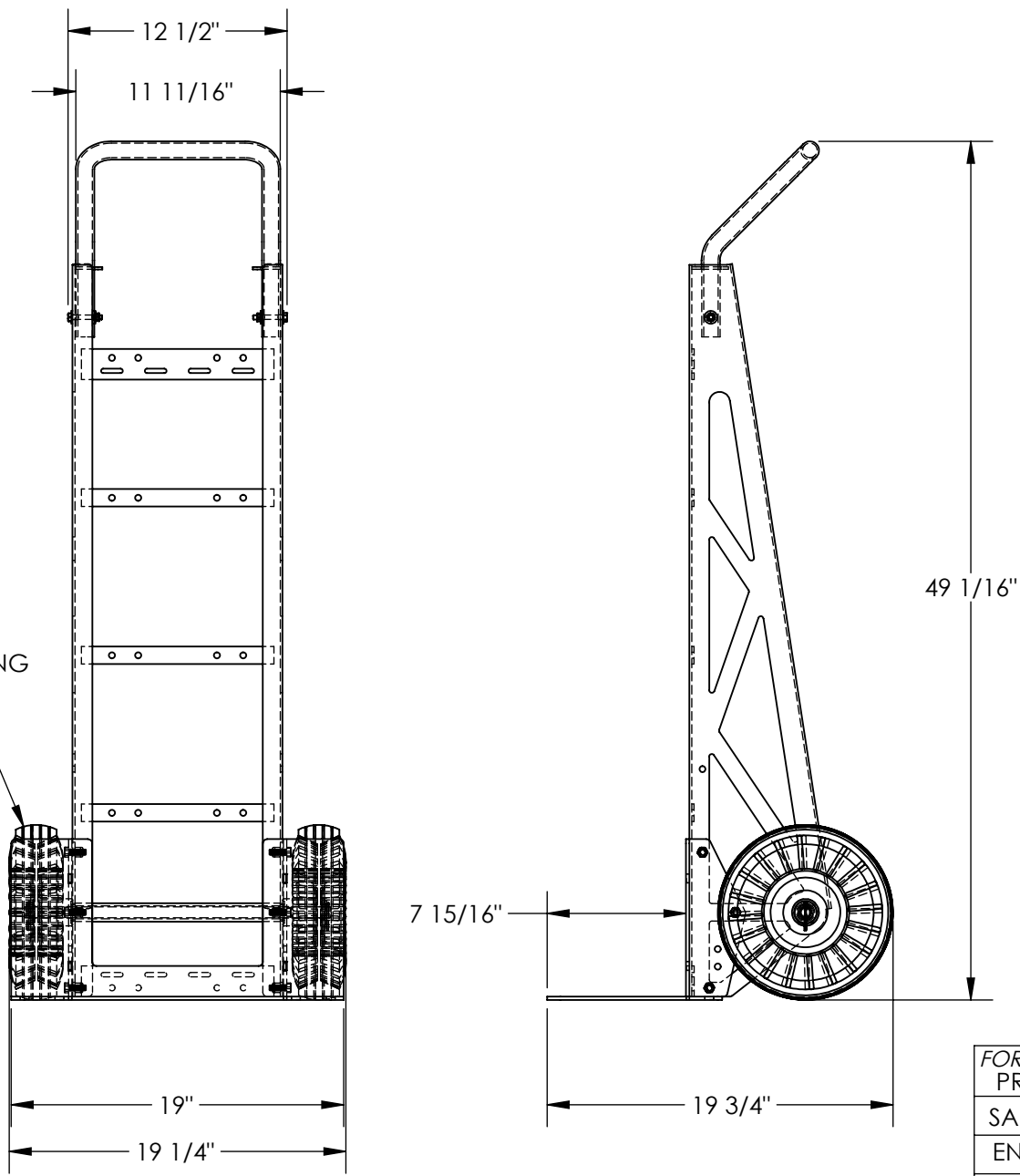

FOR INTERNAL USE ONLY PROJECT SIGN OFF	
SALES	
ENG.	
FAB.	
POWER	

ALL GRAPHICS PROVIDED ARE FOR REFERENCE ONLY. IF CERTAIN DIMENSIONS ARE CRITICAL PLEASE VERIFY THOSE DIMENSIONS WITH YOUR SALESPERSON

## STANDARD FEATURES

- MODEL NUMBER IS SPHT-660-BSG
- CAPACITY IS 660 LBS
- OVERALL WIDTH IS 19 1/4"
- USABLE WIDTH IS 19"
- OVERALL LENGTH IS 19 3/4"
- USABLE LENGTH IS 7 15/16"
- OVERALL HEIGHT IS 49 1/16"
- TOUGH BAKED IN POWDER COATED BATTLESHIP GREY FINISH
- 10" SHOCK ABSORBING WHEELS

## SPECIAL FEATURES

NONE

DIMENSION TOLERANCE ± 1/4"

<b>A P P R O V A L</b>	I, THE UNDERSIGNED, AGREE THAT THE PRODUCT AS REPRESENTED SATISFIES DESIGN AND DIMENSION REQUIREMENTS. I ALSO ACKNOWLEDGE MY DUTY TO CONFIRM PRODUCT AND INSTALLATION COMPLIANCE WITH ALL APPLICABLE FEDERAL, STATE AND LOCAL REGULATIONS AND STANDARDS.	
	<b>ANY MODIFIED UNITS ARE NON-RETURNABLE</b>	
	[ ] As drawn      [ ] As marked	
	Signed: _____ Date: _____	
Printed Name: _____		
<i>LEAD TIME WILL START UPON RECEIPT OF SIGNED APPROVAL DRAWING</i>		

DISTRIBUTOR'S NAME:		P.O.#
<b>VESTIL MANUFACTURING</b>		X
DRAWN BY: JGP		W.O.#
DATE: 7/22/2020		X
REFERENCE: X	SCALE: 1:10	SALES: X
QUOTED LEAD TIME: X	QUOTE # X	FILE NAME:
		16-007-501-008