

# VARIABLE HEIGHT SHEET RACK- VHSR-8

APPROX WEIGHT: 250.68 lbs.  
DOES NOT INCLUDE WEIGHT OF POWER OR PACKAGING!!!

\*\*\* ANY ADDITIONS, DELETIONS, OR OMISSIONS MUST BE CORRECTED ON THIS DRAWING AS THIS DRAWING WILL BE CONSIDERED ALL INCLUSIVE \*\*\*

ALL GRAPHICS PROVIDED ARE FOR REFERENCE ONLY. IF CERTAIN DIMENSIONS ARE CRITICAL PLEASE VERIFY THOSE DIMENSIONS WITH YOUR SALESPERSON

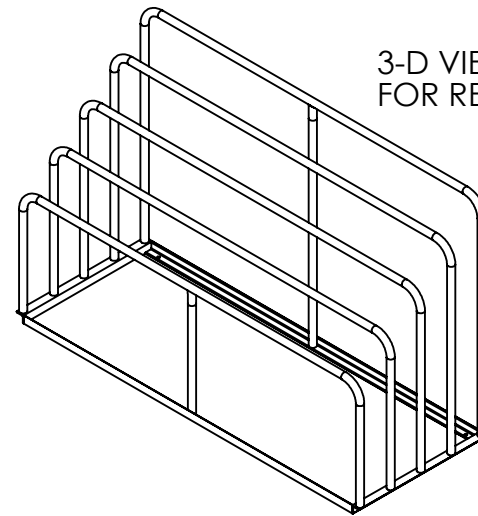
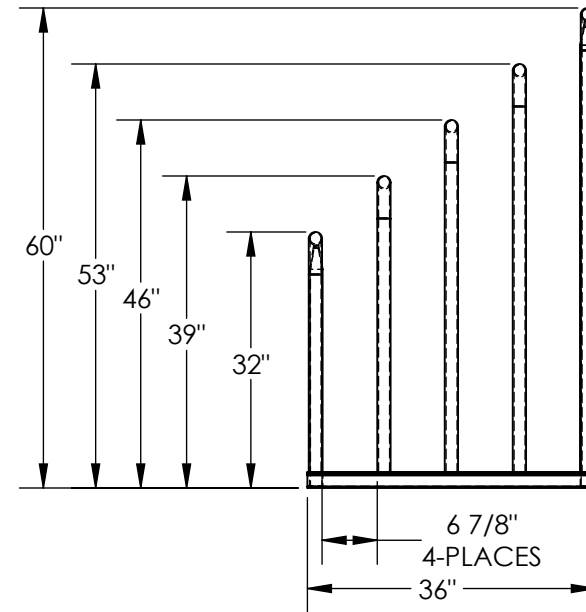
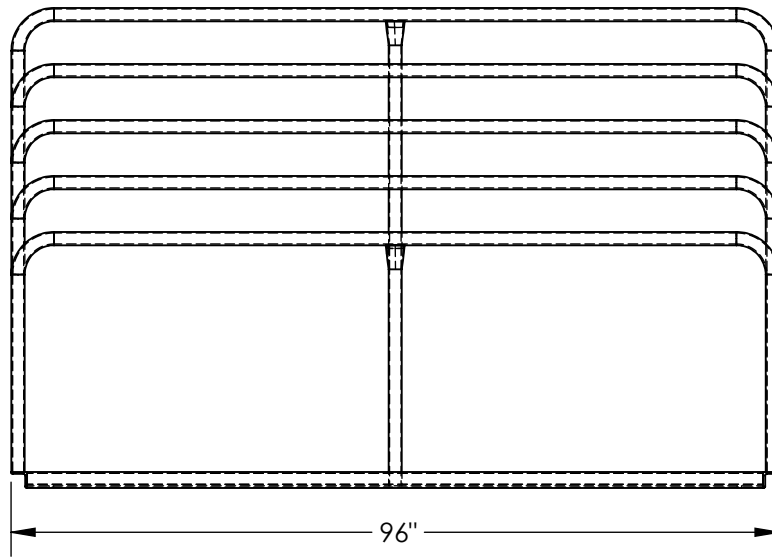

3-D VIEW  
FOR REFERENCE

DIMENSION TOLERANCE  $\pm 1/4"$

## STANDARD FEATURES

- MODEL NUMBER IS VHSR-8
- 4 BAYS FOR STORAGE
- 6 7/8" OPENING BETWEEN DIVIDERS
- CAPACITY IS 1,500 LBS PER BAY
- OVERALL HEIGHT IS: 60"
- OVERALL LENGTH IS: 36"
- OVERALL WIDTH IS: 96"
- BASE HAS 4 LAG DOWN HOLES FOR 1/2" LAG BOLTS (NOT SHOWN)
- TOUGH BAKED IN POWDER COATED BLUE FINISH

## SPECIAL FEATURES

NONE

<b>APPROVAL</b>	I, THE UNDERSIGNED, AGREE THAT THE PRODUCT AS REPRESENTED SATISFIES DESIGN AND DIMENSION REQUIREMENTS. I ALSO ACKNOWLEDGE MY DUTY TO CONFIRM PRODUCT AND INSTALLATION COMPLIANCE WITH ALL APPLICABLE FEDERAL, STATE AND LOCAL REGULATIONS AND STANDARDS.	
	<b>ANY MODIFIED UNITS ARE NON-RETURNABLE</b>	
	[ ] As drawn      [ ] As marked	
	Signed: _____	Date: _____
Printed Name: _____		
<b>LEAD TIME WILL START UPON RECEIPT OF SIGNED APPROVAL DRAWING</b>		

FOR INTERNAL USE ONLY PROJECT SIGN OFF	
SALES	
ENG.	
FAB.	
POWER	

DISTRIBUTOR'S NAME:		P.O.#
VESTIL MANUFACTURING		X
DRAWN BY: T.MOORE		DATE: 04/26/2010
REFERENCE: X		SCALE: 1:24
QUOTED LEAD TIME: X	QUOTE #	FILE NAME:
	X	31-007-117