

# FORK MOUNTED INVERTED RUG-RAM - CRP-120

APPROX WEIGHT: 478.46 lbs.  
 DOES NOT INCLUDE WEIGHT OF POWER OR PACKAGING!!!

\*\*\* ANY ADDITIONS, DELETIONS, OR OMISSIONS MUST BE CORRECTED ON THIS DRAWING AS THIS DRAWING WILL BE CONSIDERED ALL INCLUSIVE \*\*\*

ALL GRAPHICS PROVIDED ARE FOR REFERENCE ONLY. IF CERTAIN DIMENSIONS ARE CRITICAL PLEASE VERIFY THOSE DIMENSIONS WITH YOUR SALESPERSON

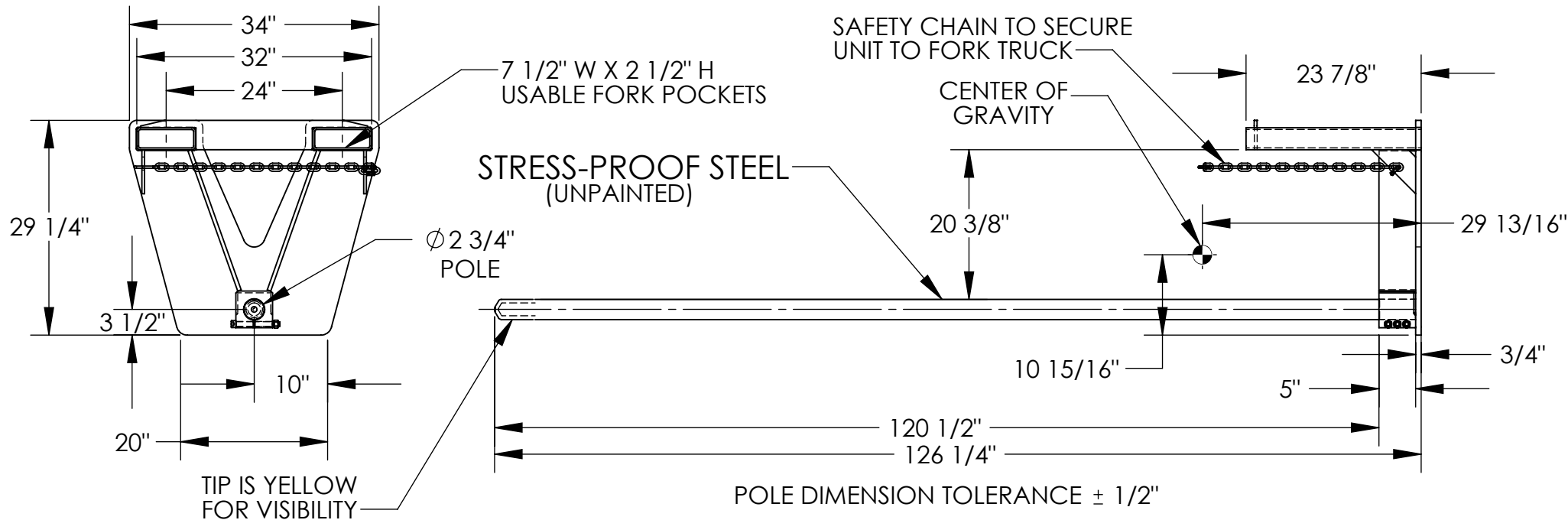

HORIZONTAL CENTER OF GRAVITY: 29 13/16"  
 VERTICAL CENTER OF GRAVITY: 10 15/16"  
 LOST LOAD: 479 LBS. (APPROX.)

NOTE: NEVER EXCEED LOAD CENTER RATING PER FORK TRUCK MANUFACTURER'S GUIDELINES. DO NOT USE THIS FORK TRUCK ATTACHMENT IF LOAD WILL EXCEED FORK TRUCK MANUFACTURER'S LOAD CENTER RATING.

DIMENSION TOLERANCE ± 1/4"

## STANDARD FEATURES

- MODEL NUMBER: CRP-120
- CAPACITY: 2,200 LBS. UNIFORM CAPACITY
- POLE LENGTH: 120 1/2"
- POLE DIAMETER: 2 3/4"
- OVERALL LENGTH: 126 1/4"
- OVERALL HEIGHT: 29 1/4"
- OVERALL WIDTH: 34"
- FORK POCKETS ARE 7 1/2" W x 2 1/2" H
- USABLE ON 24" FORK CENTERS
- WITH SAFETY CHAIN TO SECURE TO THE UNIT TO THE MAST OF THE FORK TRUCK
- DURABLE LIQUID PAINT BLUE FINISH

## SPECIAL FEATURES

NONE

<b>APPROVAL</b>	I, THE UNDERSIGNED, AGREE THAT THE PRODUCT AS REPRESENTED SATISFIES DESIGN AND DIMENSION REQUIREMENTS. I ALSO ACKNOWLEDGE MY DUTY TO CONFIRM PRODUCT AND INSTALLATION COMPLIANCE WITH ALL APPLICABLE FEDERAL, STATE AND LOCAL REGULATIONS AND STANDARDS.	
	<b>ANY MODIFIED UNITS ARE NON-RETURNABLE</b>	
	[ ] As drawn      [ ] As marked	
Signed: _____		Date: _____
Printed Name: _____		
<b>LEAD TIME WILL START UPON RECEIPT OF SIGNED APPROVAL DRAWING</b>		

FOR INTERNAL USE ONLY PROJECT SIGN OFF	
SALES	
ENG.	
FAB.	
POWER	

DISTRIBUTOR'S NAME:		P.O.#
VESTIL MANUFACTURING		X
DRAWN BY: BJW		W.O.#
DATE: 1/12/2008		X
REFERENCE: X	SCALE: 1:20	SALES: X
QUOTED LEAD TIME: X	QUOTE #	FILE NAME:
	X	08-007-056