

FORK MOUNTED INVERTED RUG-RAM - CRP-144

APPROX WEIGHT: 518.89 lbs.
 DOES NOT INCLUDE WEIGHT OF POWER OR PACKAGING!!!

*** ANY ADDITIONS, DELETIONS, OR OMISSIONS MUST BE CORRECTED ON THIS DRAWING AS THIS DRAWING WILL BE CONSIDERED ALL INCLUSIVE ***

ALL GRAPHICS PROVIDED ARE FOR REFERENCE ONLY. IF CERTAIN DIMENSIONS ARE CRITICAL PLEASE VERIFY THOSE DIMENSIONS WITH YOUR SALESPERSON

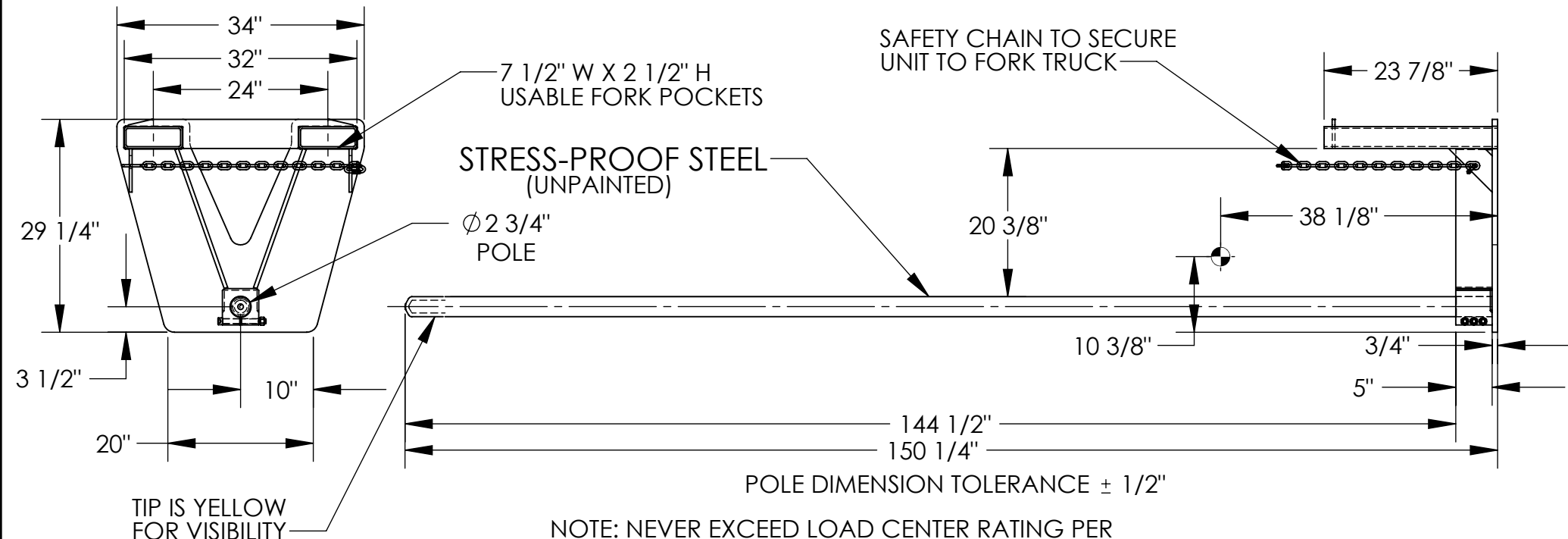

HORIZONTAL CENTER OF GRAVITY: 38 1/8"
 VERTICAL CENTER OF GRAVITY: 10 3/8"
 LOST LOAD: 519 LBS. (APPROX.)

NOTE: NEVER EXCEED LOAD CENTER RATING PER
 FORK TRUCK MANUFACTURER'S GUIDELINES.
 DO NOT USE THIS FORK TRUCK ATTACHMENT
 IF LOAD WILL EXCEED FORK TRUCK
 MANUFACTURER'S LOAD CENTER RATING.

DIMENSION TOLERANCE ± 1/4"

STANDARD FEATURES

- MODEL NUMBER: CRP-144
- CAPACITY: 1,800 LBS. UNIFORM CAPACITY
- POLE LENGTH: 144 1/2"
- POLE DIAMETER: 2 3/4"
- OVERALL LENGTH: 150 1/4"
- OVERALL HEIGHT: 29 1/4"
- OVERALL WIDTH: 34"
- FORK POCKETS ARE 7 1/2" W x 2 1/2" H
 USABLE ON 24" FORK CENTERS
- WITH SAFETY CHAIN TO SECURE TO THE
 UNIT TO THE MAST OF THE FORK TRUCK
- DURABLE LIQUID PAINT BLUE FINISH

SPECIAL FEATURES

NONE

APPROVAL	I, THE UNDERSIGNED, AGREE THAT THE PRODUCT AS REPRESENTED SATISFIES DESIGN AND DIMENSION REQUIREMENTS. I ALSO ACKNOWLEDGE MY DUTY TO CONFIRM PRODUCT AND INSTALLATION COMPLIANCE WITH ALL APPLICABLE FEDERAL, STATE AND LOCAL REGULATIONS AND STANDARDS.	
	ANY MODIFIED UNITS ARE NON-RETURNABLE	
	[] As drawn [] As marked	
	Signed: _____	Date: _____
Printed Name: _____		
LEAD TIME WILL START UPON RECEIPT OF SIGNED APPROVAL DRAWING		

FOR INTERNAL USE ONLY PROJECT SIGN OFF	
SALES	
ENG.	
FAB.	
POWER	

DISTRIBUTOR'S NAME:		P.O.#
VESTIL MANUFACTURING		X
DRAWN BY: BJW		W.O.#
DATE: 1/12/2008		X
REFERENCE: X	SCALE: 1:20	SALES: X
QUOTED LEAD TIME: X	QUOTE #	FILE NAME:
	X	08-007-057