

HYDRAULIC CRATE TURNER - CTD-H-TP-3000

APPROX WEIGHT: 433.37 lbs.
DOES NOT INCLUDE WEIGHT OF POWER OR PACKAGING!!!

*** ANY ADDITIONS, DELETIONS, OR OMISSIONS MUST BE CORRECTED ON THIS DRAWING AS THIS DRAWING WILL BE CONSIDERED ALL INCLUSIVE ***

ALL GRAPHICS PROVIDED ARE FOR REFERENCE ONLY. IF CERTAIN DIMENSIONS ARE CRITICAL PLEASE VERIFY THOSE DIMENSIONS WITH YOUR SALESPERSON

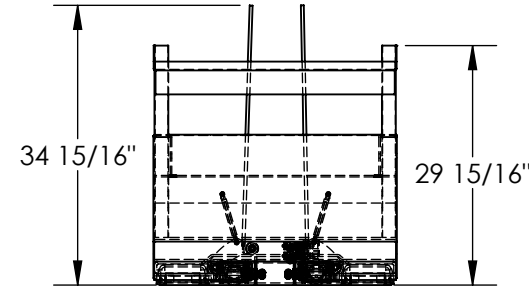
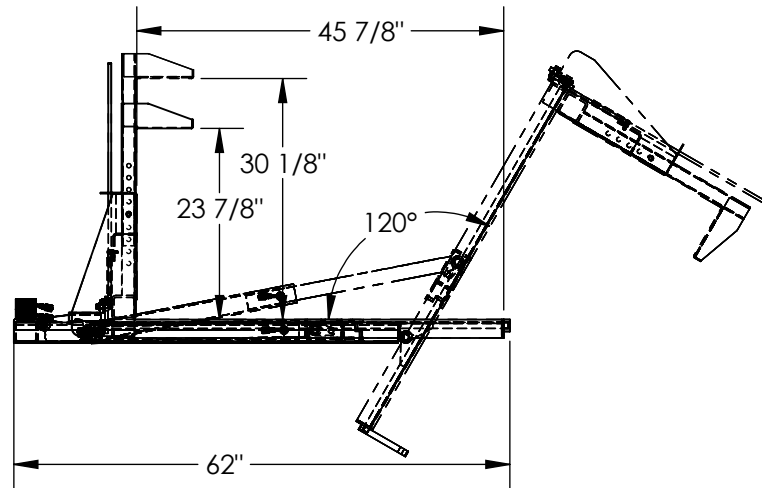
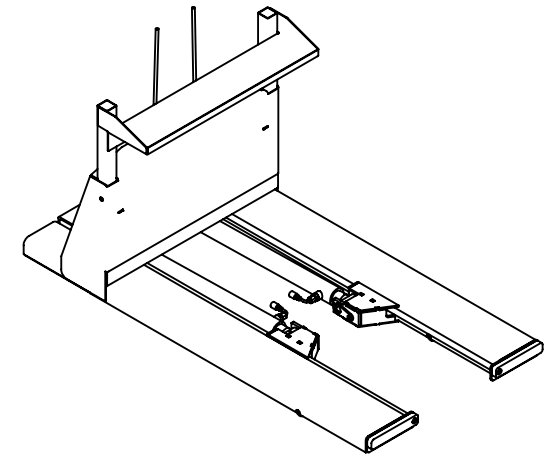
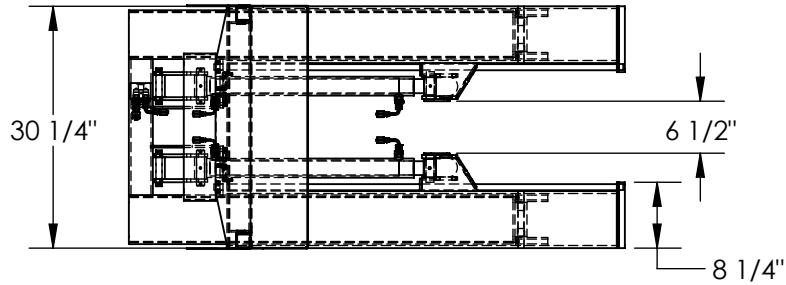

DIMENSION TOLERANCE $\pm 1/4$ "

STANDARD FEATURES

- MODEL NUMBER IS CTD-H-TP-3000
- OVERALL WIDTH IS 30 1/4"
- OVERALL LENGTH IS 62"
- USABLE LENGTH IS 45 7/8"
- OVERALL HEIGHT IS 34 15/16"
- USEBLE HEIGHT IS 23 7/8"
- OVERALL TILT IS 120°
- MAX CAPACITY IS 3000 LBS
- DURABLE LIQUID PAINT YELLOW FINISH

SPECIAL FEATURES

NONE

APPROX. WEIGHT / LOST LOAD = 433.37
MINIMIM EFFECTIVE THICKNESS = LESS THAN 1"
NEVER EXCEED LOAD CENTER
RATING PER FORKTRUCK
MANUFACTURERS GUIDELINES.
DO NOT USE THIS FORK TRUCK
ATTACHMENT IF LOAD WILL
EXCEED FORK TRUCK MANUFACTURER'S
LOAD CENTER RATING

FOR INTERNAL USE ONLY PROJECT SIGN OFF	
SALES	
ENG.	
FAB.	
POWER	

APPROVAL

I, THE UNDERSIGNED, AGREE THAT THE PRODUCT AS REPRESENTED SATISFIES DESIGN AND DIMENSION REQUIREMENTS. I ALSO ACKNOWLEDGE MY DUTY TO CONFIRM PRODUCT AND INSTALLATION COMPLIANCE WITH ALL APPLICABLE FEDERAL, STATE AND LOCAL REGULATIONS AND STANDARDS.
UNITS REQUIRING APPROVAL DRAWINGS OR MODIFIED ARE NON-RETURNABLE

As drawn As marked

Signed: _____ Date: _____

Printed Name: _____

LEAD TIME WILL START UPON RECEIPT OF SIGNED APPROVAL DRAWING

DISTRIBUTOR'S NAME:		P.O.#
VESTIL MANUFACTURING		X
DRAWN BY: TAL	DATE: 8/24/2020	W.O.#
REFERENCE: X	SCALE: 1:24	X
QUOTED LEAD TIME: X	QUOTE #	FILE NAME:
	X	15-007-163