



Vestil Manufacturing Corp.
 2999 North Wayne Street, P.O. Box 507, Angola, IN 46703
 Telephone: (260) 665-7586 -or- Toll Free (800) 348-0868
 Fax: (260) 665-1339
 www.vestilmfg.com e-mail: info@vestil.com

DCR-880 Series Manually Propelled Drum Carriers Instruction Manual



DCR-880-M



DCR-880-H-HP



DCR-880-H

Receiving Instructions

After delivery, remove the packaging from the product. Inspect the product closely to determine whether it sustained damage during transport. If damage is discovered, record a complete description of it on the bill of lading. If the product is undamaged, discard the packaging.

NOTE: The end-user is solely responsible for confirming that product design, use, and maintenance comply with laws, regulations, codes, and mandatory standards applied where the product is used.

Technical Service & Replacement Parts

For answers to questions not addressed in these instructions and to order replacement parts, labels, and accessories, call our Technical Service and Parts Department at (260) 665-7586. The department can also be contacted online at http://www.vestilmfg.com/parts_info.htm.

Electronic copies of Instruction Manuals

Additional copies of this instruction manual may be downloaded from <https://www.vestil.com/page-manuals.php>.

Table of Contents

Signal words.....	2
Safety instructions.....	2
DCR-880-M exploded view, bill of materials, and specifications.....	3 - 4
DCR-880-H exploded view, bill of materials, and specifications.....	5 - 6
DCR-880-H-HP exploded view, bill of materials, and specifications.....	7 - 8
DCR-880-H-DC exploded view, bill of materials, and specifications.....	9 - 10
DCR-880-H-HP-DC exploded view, bill of materials, and specifications.....	11 - 12
*DC modular power unit exploded view and bill of materials.....	13 - 14
*12VDC modular power unit electrical circuit diagram.....	14
*12VDC modular power unit layout.....	15
Record of Satisfactory Condition.....	16
Using the drum lifter.....	16
Lifting drums.....	17
Hydraulic circuit diagram (DCR-880-H & DCR-880-H-HP).....	18
Manual hydraulic system sequence of operation.....	18 - 19
*Hydraulic circuit diagram: DC-powered units.....	19
*Operation instructions for DC-powered units (DCR-880-H-DC & DCR-800-H-HP-DC).....	19 - 20
Bleeding air from the hydraulic circuit.....	20
Using the Battery Charger.....	20 - 21
Inspections & Maintenance.....	21 - 22
Troubleshooting guide (DCR-880-H & DCR-880-H-HP).....	22
Troubleshooting guide (DCR-880-H-DC & DCR-880-H-HP-DC).....	23 - 24
Labeling diagram.....	24
Limited warranty.....	25

*NOTE: Pages 13-15, 19-20 provide views of, and instructions about, the modular power unit. These diagrams only apply to units manufactured **before** 12-01-2018. Units manufactured on or after 12-01-2018 receive the 2nd generation modular power unit (MPU GEN2). Diagrams and operating instructions for GEN2 power units are provided in separate MPU-AC/DC manuals.*

SIGNAL WORDS

This manual uses SIGNAL WORDS to indicate the likelihood of personal injuries, as well as the probable seriousness of those injuries, if the product is misused in the ways described. Other signal words call attention to uses of the product likely cause property damage. The signal words used appear below along with the meaning of each word.



DANGER Identifies a hazardous situation which, if not avoided, WILL result in DEATH or SERIOUS INJURY. Use of this signal word is limited to the most extreme situations.



WARNING Identifies a hazardous situation which, if not avoided, COULD result in DEATH or SERIOUS INJURY.



CAUTION Indicates a hazardous situation which, if not avoided, COULD result in MINOR or MODERATE injury.



NOTICE Identifies practices likely to result in product/property damage, such as operation that might damage the product.

SAFETY INSTRUCTIONS

Vestil strives to identify foreseeable hazards associated with the use of its products. However, no manual can address every conceivable risk. The most effective way to avoid injury is to exercise sound judgment when assembling, using, inspecting, and maintaining this product. **Keep a copy of this manual with the product at all times.** For example, put a copy inside a plastic pouch and attach the pouch to the frame. **Anyone who uses this product must be made aware that a copy of the manual is available and where to find it.**



WARNING Serious personal injuries might result from improper or careless use of this product.

- **Failure to read & understand the entire manual before using or servicing the product is a misuse of the product.** Read the manual to refresh your understanding of proper use and maintenance procedures.
- DO NOT attempt to resolve any problem(s) with the product unless you are both authorized to do so and certain that it will be safe to use afterwards.
- DO NOT modify the product in any way UNLESS you first obtain written approval from Vestil. Unapproved modifications might make the lift unsafe to use and automatically void the [Limited Warranty](#) on [p. 25](#).
- DO NOT exceed the capacity of the drum handler. The product is labeled with its capacity. See Label 287 in [Labeling diagram](#) on [p. 24](#).
- Inspect the product as directed in [Inspections & Maintenance](#) on [p. 21-22](#). ONLY use the drum handler if it is in normal condition. If repairs are necessary, only install manufacturer-approved replacement parts.
- DO NOT change the setting of the pressure relief valve.
- ALWAYS carefully watch the drum handler and drum during use.
- DO NOT use this device UNLESS all product labels are readable and undamaged as shown in the [Labeling diagram](#) on [p. 24](#) AND all machine guards are in place.
- DO NOT ride on the drum handler or use it to move people.
- ALWAYS lower the carriage until the drum is entirely supported by the ground before leaving the drum handler.
- If part of the hydraulic system is damaged, AVOID contact with pressurized oil. High pressure oil easily punctures skin which can cause injury, gangrene, or death.
- Unload the drum handler before performing any service work on it.
- The unit should always be labeled as shown in the [Labeling Diagram](#) on [p. 24](#). Replace all labels that are damaged, missing, or not easily readable.
- DO NOT use the drum handler if it cannot firmly and securely clamp the lip of the drum.
- Only use this product on compacted, improved surfaces.



NOTICE Proper use, maintenance, and storage are essential for this product to function properly.

- Always use this product in accordance with the instructions in this manual.
- Relieve hydraulic pressure whenever the unit is not in use by fully lowering the carriage.
- Keep the product clean & dry. Lubricate moving parts at least once per month.
- ONLY use manufacturer-approved replacement parts. Vestil is not responsible for issues or malfunctions that result from the use of unapproved replacement parts.
- DCR-880-H and DCR-880-H-HP: Do not use brake fluid or jack oils in the hydraulic system. If oil is needed, use an anti-wear hydraulic oil with a viscosity grade of 150 SUS at 100°F, (ISO 32 cSt @ 40°C), or Dexron transmission fluid.
- Contact the manufacturer for MSDS information

DCR-880-M Exploded View (Bill of Materials on Following Page)

40-006-013

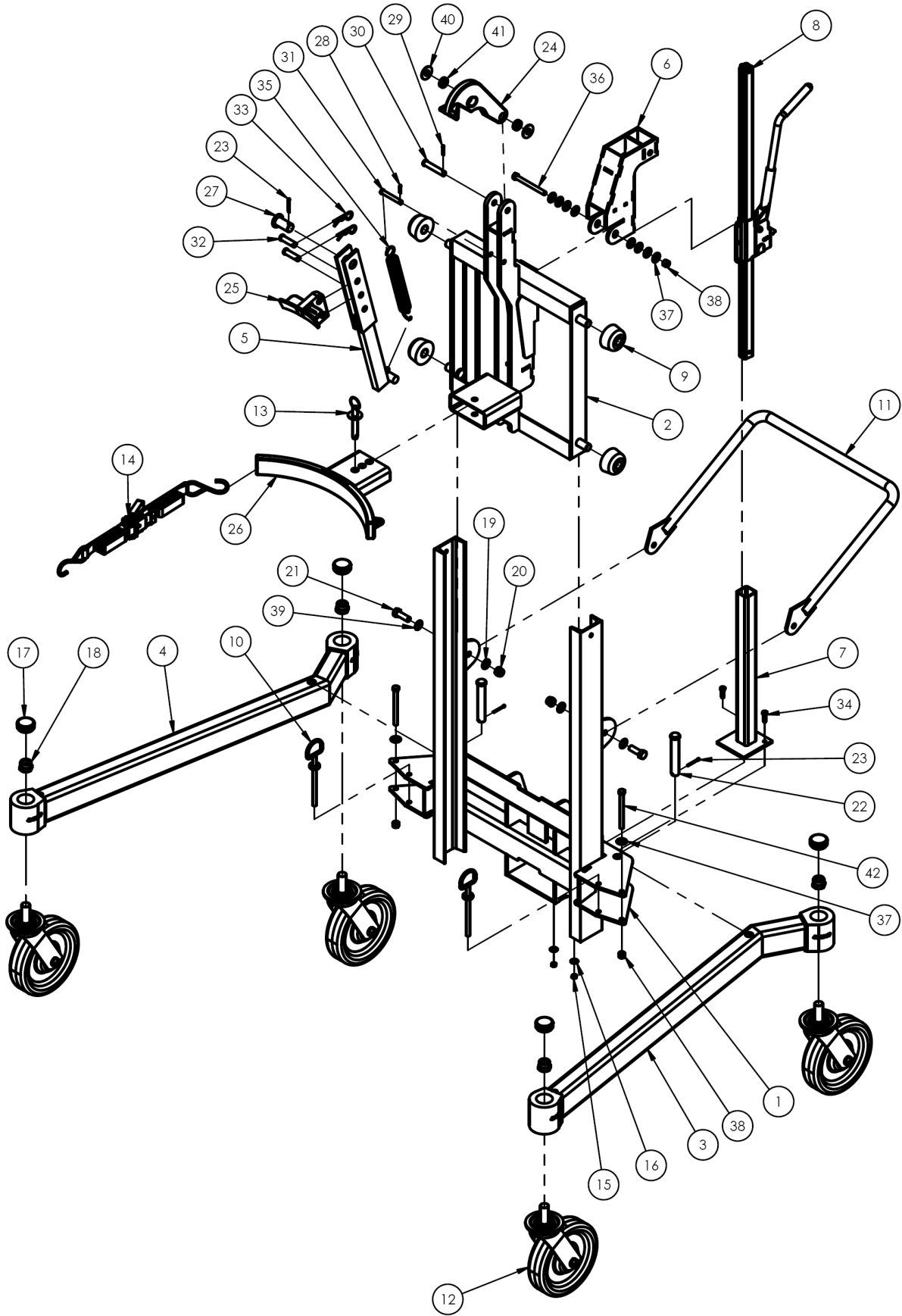

DCR-880-M bill of materials

Item	Part no.	Description	Qty.	Item	Part no.	Description	Qty.
1	40-514-028	Weldment, frame	1	22	28-112-031	Pin, clevis, $\frac{3}{4}$ " x $4\frac{1}{2}$ "	2
2	40-538-011	Weldment, carriage	1	23	65078	Extended prong cotter pin, zinc-finish, $\frac{1}{8}$ " x $1\frac{1}{2}$ "	3
3	40-514-029	Weldment, leg, left	1	24	40-016-052	Bracket, casting	1
4	40-514-030	Weldment, leg, right	1	25	40-016-053	Bracket, casting, FMDL series	1
5	40-514-011	Weldment, frame	1	26	40-014-093	Frame, drum grip, casting	1
6	40-538-007	Weldment, carriage, cylinder bracket	1	27	40-612-004	Pin, clevis	1
7	40-516-006	Weldment, bracket, jack mount	1	28	65073	$\frac{1}{8}$ " x $\frac{5}{8}$ " cotter pin	1
8	40-536-001	Weldment, jack	1	29	65076	$\frac{1}{8}$ " x 1" cotter pin, zinc-plated	1
9	21-527-003	Assembly, roller bearing	4	30	40-112-016	Pin, upper casting mount	1
10	40-537-001	Weldment, detent, leg position	4	31	40-112-017	Pin, spring attach	1
11	40-525-001	Weldment, handle	1	32	21-112-003	Pin, $\frac{1}{2}$ "-13x1 $\frac{1}{2}$ ", retaining clevis	2
12	16-132-181	Stem caster, PH-F-8/2-S-STM	4	33	45286	#11 hitch pin clip, $\frac{1}{8}$ " x $2\frac{5}{8}$ "	2
13	40-612-006	Weldment, pin, saddle retainer	1	34	11005	Bolt, $\frac{1}{4}$ "-20x1", HHCS #2, zinc-plated	2
14	40-145-008	Strap with ratchet, 6' long, 2 hooks	1	35	40-146-001	Spring, tension	1
15	36102	Hex nut, grade A, zinc-plated, $\frac{1}{4}$ "-20	2	36	11119	Hex bolt, grade A, zinc finish, $\frac{3}{8}$ "-16x4"	1
16	33004	Flat washer, USS, zinc-plated, $\frac{1}{4}$ "	2	37	33008	Flat washer, low carbon, USS, zinc-plated, $\frac{3}{8}$ "	8
17	99-024-003	Guard/cover/endcap/plug	4	38	37024	Nylon insert lock nut, grade 2, zinc finish, $\frac{3}{8}$ "-16	1
18	37039	Nylock nut, zinc-plated, $\frac{3}{4}$ "-10	4	39	33354	Belleville spring washer, $\frac{1}{2}$ "ID	2
19	33011	Flat washer, USS, plain finish, $\frac{1}{2}$ "	2	40	33012	Flat washer, low carbon, zinc finish, $\frac{1}{2}$ "	2
20	37030	Nylon insert lock nut, $\frac{1}{2}$ "-13	2	41	21-113-030	Spacer, $\frac{1}{4}$ " length	2
21	11209	Bolt, $\frac{1}{2}$ "-13x1 $\frac{1}{2}$ " HHCS ASTM A307 grade A, zinc-plated	2	42	11120	Hex bolt, gr. A, zinc finish, $\frac{3}{8}$ "-16 x $4\frac{1}{4}$ "	2

DIMENSION TOLERANCE $\pm \frac{1}{4}$ "

1" = 2.54cm
2.2 lb. = 1kg

DCR-880-M Standard Features

Capacity	= 880 lb. (400kg)	Maximum inside width	= 61 $\frac{7}{16}$ "
Frame height	= 41 $\frac{1}{2}$ " (115.6cm)	Minimum inside width	= 30 $\frac{1}{4}$ "
Overall raised height	= 54 $\frac{3}{16}$ " (137.6cm)	Jaw raised height	= 45 $\frac{3}{4}$ "
Maximum overall length	= 49 $\frac{7}{8}$ " (110.6cm)	Jaw lowered height	= 31 $\frac{3}{4}$ "
Minimum overall length	= 43 $\frac{9}{16}$ " (126.8cm)	Casters	= 8"x2", swiveling
Maximum overall width	= 68 $\frac{15}{16}$ "	Net weight	= 238 lb. (108.2kg)
Minimum overall width	= 37 $\frac{3}{4}$ "	Manual ratchet operated	

DCR-880-H Exploded View (Bill of Materials on Following Page)

40-006-021

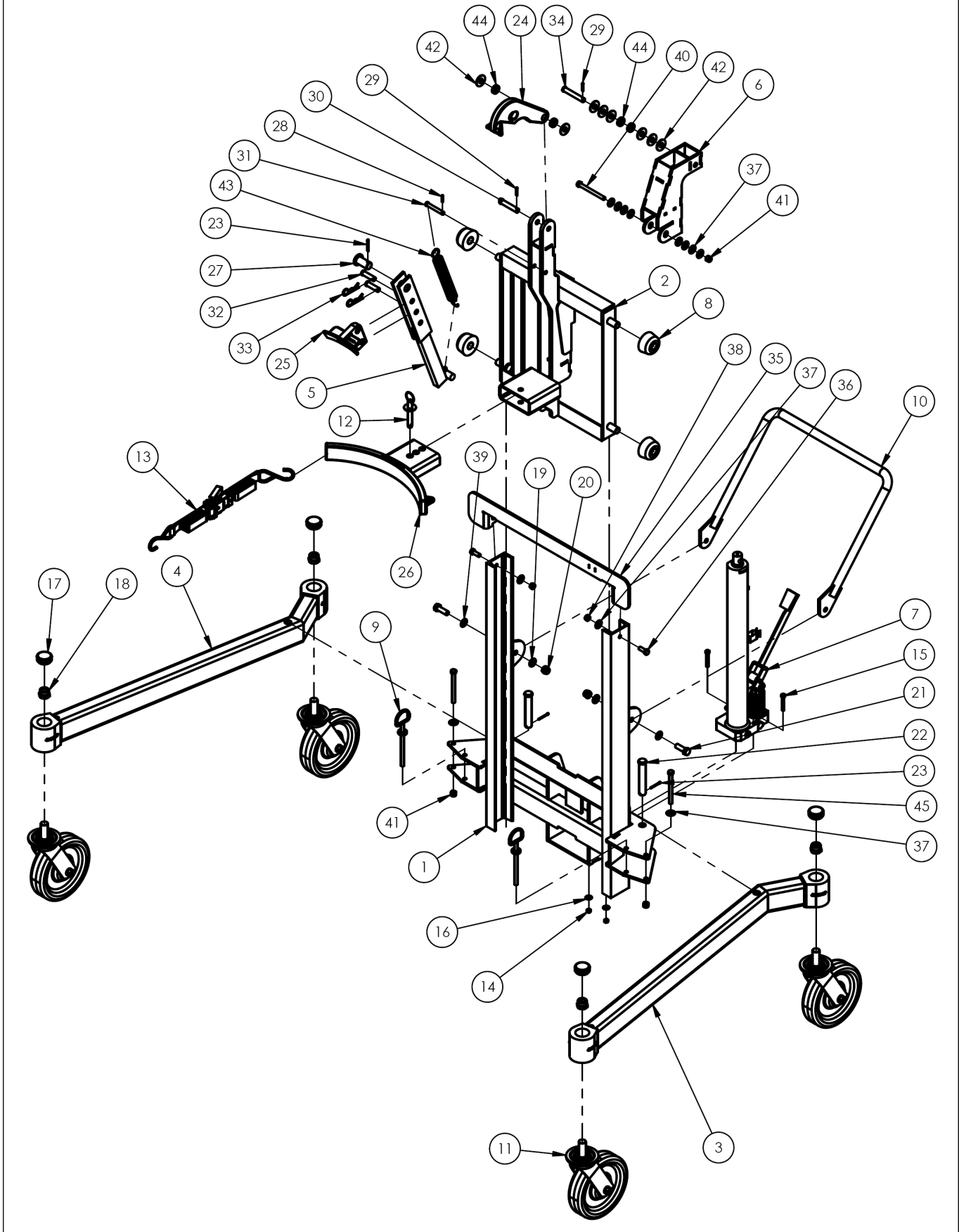

DCR-880-H bill of materials

Item	Part no.	Description	Qty.	Item	Part no.	Description	Qty.
1	40-514-028	Weldment, frame	1	24	40-016-052	Bracket, casting	1
2	40-538-011	Weldment, carriage	1	25	40-016-053	Bracket, casting, FMDL series	1
3	40-514-029	Weldment, leg, left	1	26	40-014-093	Frame, drum grip, casting	1
4	40-514-030	Weldment, leg, right	1	27	40-612-004	Pin, clevis	1
5	40-514-011	Weldment, frame	1	28	65073	1/8" x 5/8" cotter pin	1
6	40-538-007	Weldment, carriage, cylinder bracket	1	29	65076	1/8" x 1" cotter pin, zinc-plated	2
7	01-640-030	Pump, manual	1	30	40-112-016	Pin, upper casting mount	1
8	21-527-003	Assembly, roller bearing	4	31	40-112-017	Pin, spring attach	1
9	40-537-001	Weldment, detent, leg position	4	32	21-112-003	Pin, 1/2"x1 15/16", retaining clevis	2
10	40-525-001	Weldment, handle	1	33	45286	#11 hitch pin clip, 1/8" x 2 5/8"	2
11	16-132-181	Stem caster, PH-F-8/2-S-STM	4	34	40-112-015	Pin, cylinder mount	1
12	40-612-006	Weldment, pin, saddle retainer	1	35			
13	40-145-008	Strap with ratchet, 6' long, 2 hooks	1	36	21-112-003	Pin, 1/2"-13x1 1/2", retaining clevis	2
14	36102	Hex nut, grade A, zinc-plated, 1/4"-20	2	37	40-017-037	Stiffener, upper tie bar	1
15	11011	Hex bolt, grade A, zinc-plated, 1/4"-20x2"	2	38	11105	Hex bolt, 3/8"-16x1", grade A, zinc-plated	2
16	33004	Flat washer, USS, zinc-plated, 1/4"	2	39	33354	Belleville spring washer, 1/2"ID	2
17	99-024-003	Guard/cover/endcap/plug	4	40	11119	Hex bolt, grade A, zinc finish, 3/8"-16x4"	1
18	37039	Nylock nut, zinc-plated, 3/4"-10	4	41	37024	Nylon insert lock nut, grade 2, zinc finish, 3/8"-16	1
19	33011	Flat washer, USS, plain finish, 1/2"	2	42	33012	Flat washer, low carbon, zinc finish, 1/2"	2
20	37030	Nylon insert lock nut, 1/2"-13	2	43	40-146-001	Spring, tension	1
21	11209	Bolt, 1/2"-13x1 1/2" HHCS ASTM A307 grade A, zinc-plated	2	44	21-113-030	Spacer, 1/4" length	2
22	28-112-031	Pin, clevis, 3/4" x 4 1/2"	2	45	11120	Hex bolt, gr. A, zinc finish, 3/8"-16 x 4 1/4"	2
23	65078	Extended prong cotter pin, zinc-finish, 1/8" x 1 1/2"	3	*	01-136-412	Replacement seal kit for pump (item 23)	

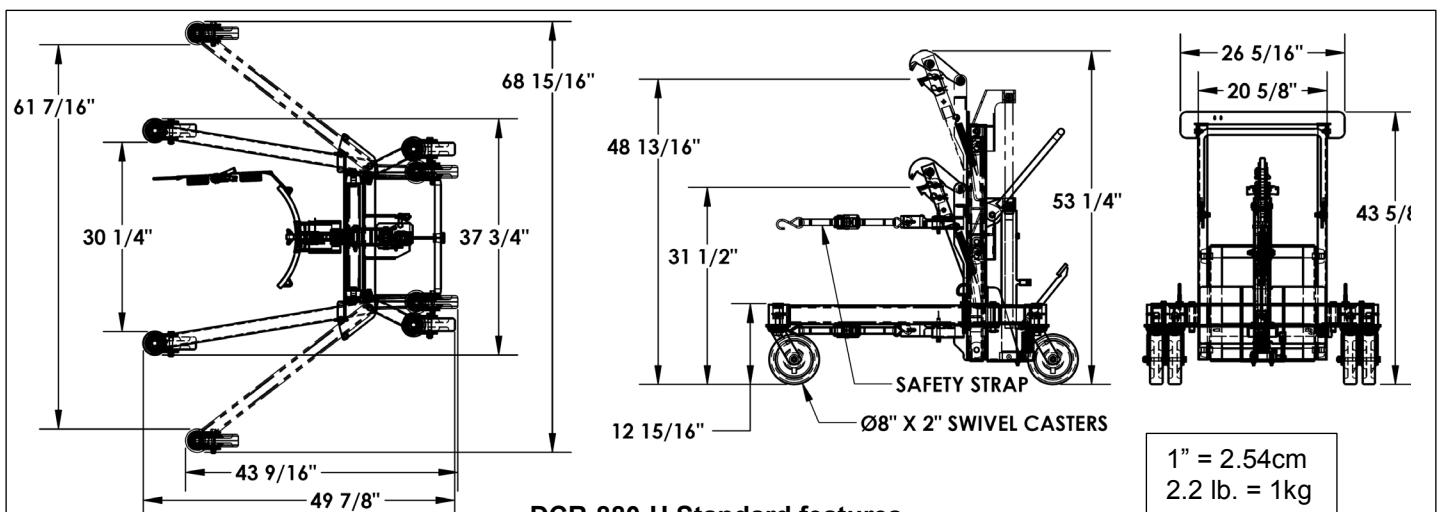

DCR-880-H Standard features

Capacity = 1,500 lb.
 Frame height = 43 5/8"
 Overall raised height = 53 1/2"
 Maximum overall length = 49 7/8"
 Minimum overall length = 43 9/16"

Lowered jaw height = 31 1/2"
 Casters = 8"x2" swiveling
 Raised jaw height = 48 13/16"
 Maximum overall width = 68 15/16"
 Minimum overall width = 37 3/4"

Maximum inside width = 61 7/16"
 Maximum inside width = 30 1/4"
 Net weight = 272 lb.
 Foot pump operated carriage

DCR-880-H-HP Exploded View (Bill of Materials on Following Page)

40-006-022

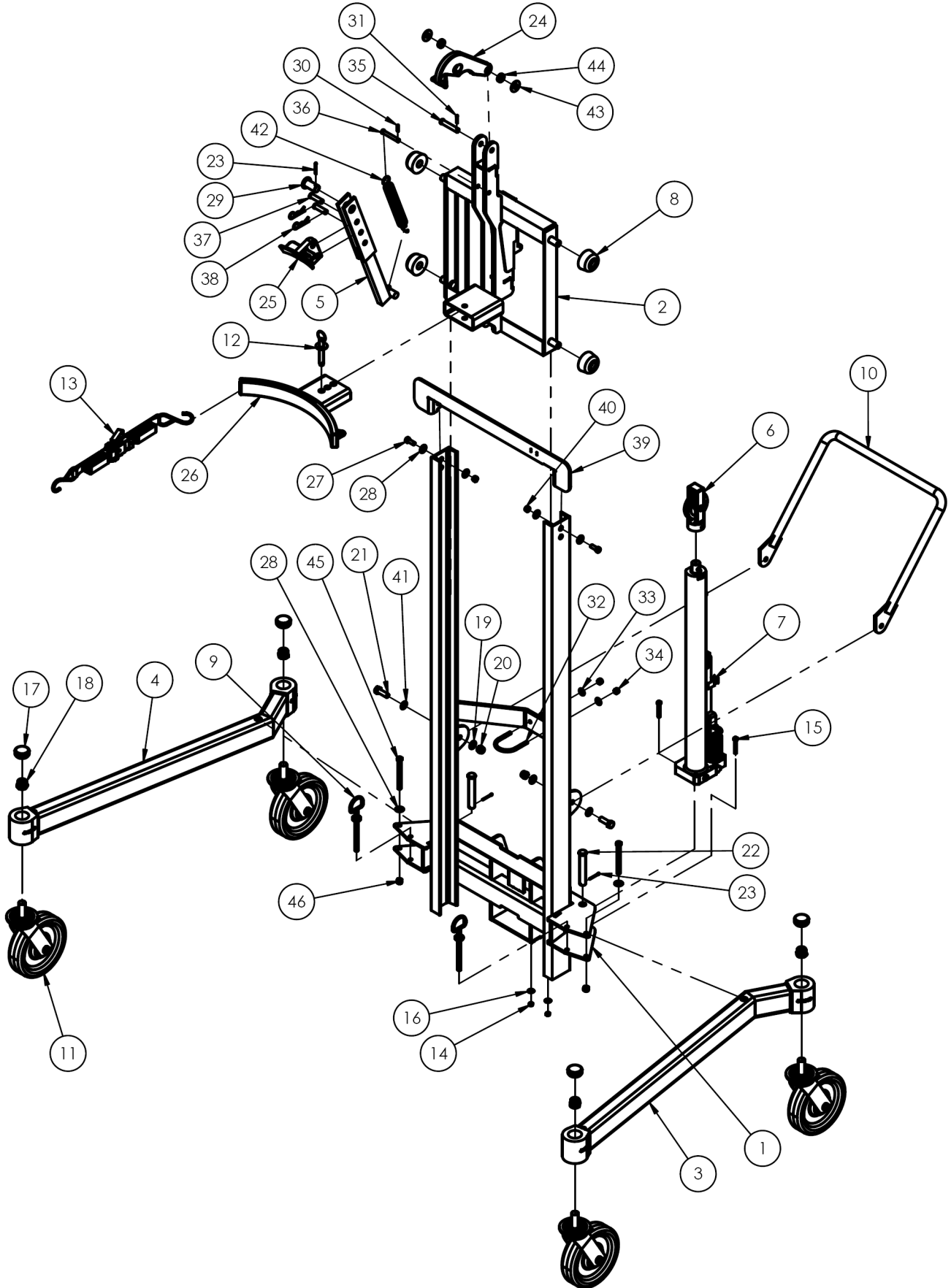

DCR-880-H-HP bill of materials

Item	Part no.	Description	Qty.	Item	Part no.	Description	Qty.
1	40-514-034	Weldment, frame	1	24	40-016-052	Bracket, casting	1
2	40-538-006	Weldment, carriage	1	25	40-016-053	Bracket, casting, FMDL series	1
3	40-514-029	Weldment, leg, left	1	26	40-014-093	Frame, drum grip, casting	1
4	40-514-030	Weldment, leg, right	1	27	11105	Hex bolt, $\frac{3}{8}$ "-16x1", grade A, zinc-plated	2
5	40-514-011	Weldment, frame	1	28	33008	Flat washer, low carbon, USS, zinc-plated, $\frac{3}{8}$ "	4
6	33-542-001	Assembly, pulley	1	29	40-612-004	Pin, clevis	1
7	01-640-031	Pump, manual, 24" stroke FHJ	1	30	65073	$\frac{1}{8}$ " x $\frac{5}{8}$ " cotter pin	1
8	21-527-003	Assembly, roller bearing	4	31	65076	$\frac{1}{8}$ " x 1" cotter pin, zinc-plated	1
9	40-537-001	Weldment, detent, leg position	4	32	42034	U-bolt, zinc-plated, $\frac{5}{16}$ "-18x2"	1
10	40-525-001	Weldment, handle	1	33	33006	Flat washer, zinc-plated, USS, $\frac{5}{16}$ "	2
11	16-132-181	Stem caster, PH-F-8/2-S-STM	4	34	37021	Nylon insert lock nut, grade 2, zinc finish, $\frac{5}{16}$ "-18	2
12	40-612-006	Weldment, pin, saddle retainer	1	35	40-112-016	Pin, upper casting mount	1
13	40-145-008	Strap with ratchet, 6' long, 2 hooks	1	36	40-112-017	Pin, spring attach	1
14	36102	Hex nut, grade A, zinc-plated, $\frac{1}{4}$ "-20	2	37	21-112-003	Pin, $\frac{1}{2}$ "x1 $\frac{15}{16}$ ", retaining clevis	2
15	11011	Hex bolt, grade A, zinc-plated, $\frac{1}{4}$ "-20x2"	2	38	45286	#11 hitch pin clip, $\frac{1}{8}$ " x 2 $\frac{5}{8}$ "	2
16	33004	Flat washer, USS, zinc-plated, $\frac{1}{4}$ "	2	39	40-017-037	Stiffener, upper tie bar	1
17	99-024-003	Guard, cover, endcap, plug	4	40	36106	Hex nut, grade A, zinc-plated, $\frac{3}{8}$ "-16	2
18	37039	Nylock nut, zinc-plated, $\frac{3}{4}$ "-10	4	41	33354	Belleville spring washer, $\frac{1}{2}$ "ID	2
19	33011	Flat washer, USS, plain finish, $\frac{1}{2}$ "	2	42	40-146-001	Spring, tension	1
20	37030	Nylon insert lock nut, $\frac{1}{2}$ "-13	2	43	33012	Flat washer, low carbon, zinc finish, $\frac{1}{2}$ "	2
21	11209	Bolt, $\frac{1}{2}$ "-13x1 $\frac{1}{2}$ " HHCS ASTM A307 grade A, zinc-plated	2	44	21-113-030	Spacer, $\frac{1}{4}$ " length	2
22	28-112-031	Clevis pin, $\frac{3}{4}$ " x 4 $\frac{1}{2}$ "	2	45	33-542-003	Assembly, chain (not shown)	1
23	65078	Extended prong cotter pin, zinc-finish, $\frac{1}{8}$ " x 1 $\frac{1}{2}$ "	3	*	01-136-412	Replacement seal kit for pump (item 4)	

DCR-880-H-HP Standard Features

Capacity	= 880 lb.	Minimum inside width	= 30 $\frac{1}{4}$ "	Maximum overall width	= 68 $\frac{15}{16}$ "
Frame height	= 72"	Maximum inside width	= 61 $\frac{7}{16}$ "	Minimum overall width	= 37 $\frac{3}{4}$ "
Maximum overall height	= 79"	Lowered jaw height	= 31 $\frac{5}{8}$ "	Net weight	= 301 lb.
Maximum overall length	= 49 $\frac{7}{8}$ "	Raised jaw height	= 74 $\frac{9}{16}$ "	Foot pump operated carriage	
Minimum overall length	= 43 $\frac{9}{16}$ "	Casters	= 8"x2" swiveling		

1" = 2.54cm
2.2 lb. = 1kg

DCR-880-H-DC Exploded View (Bill of Materials on Following Page)

40-006-051

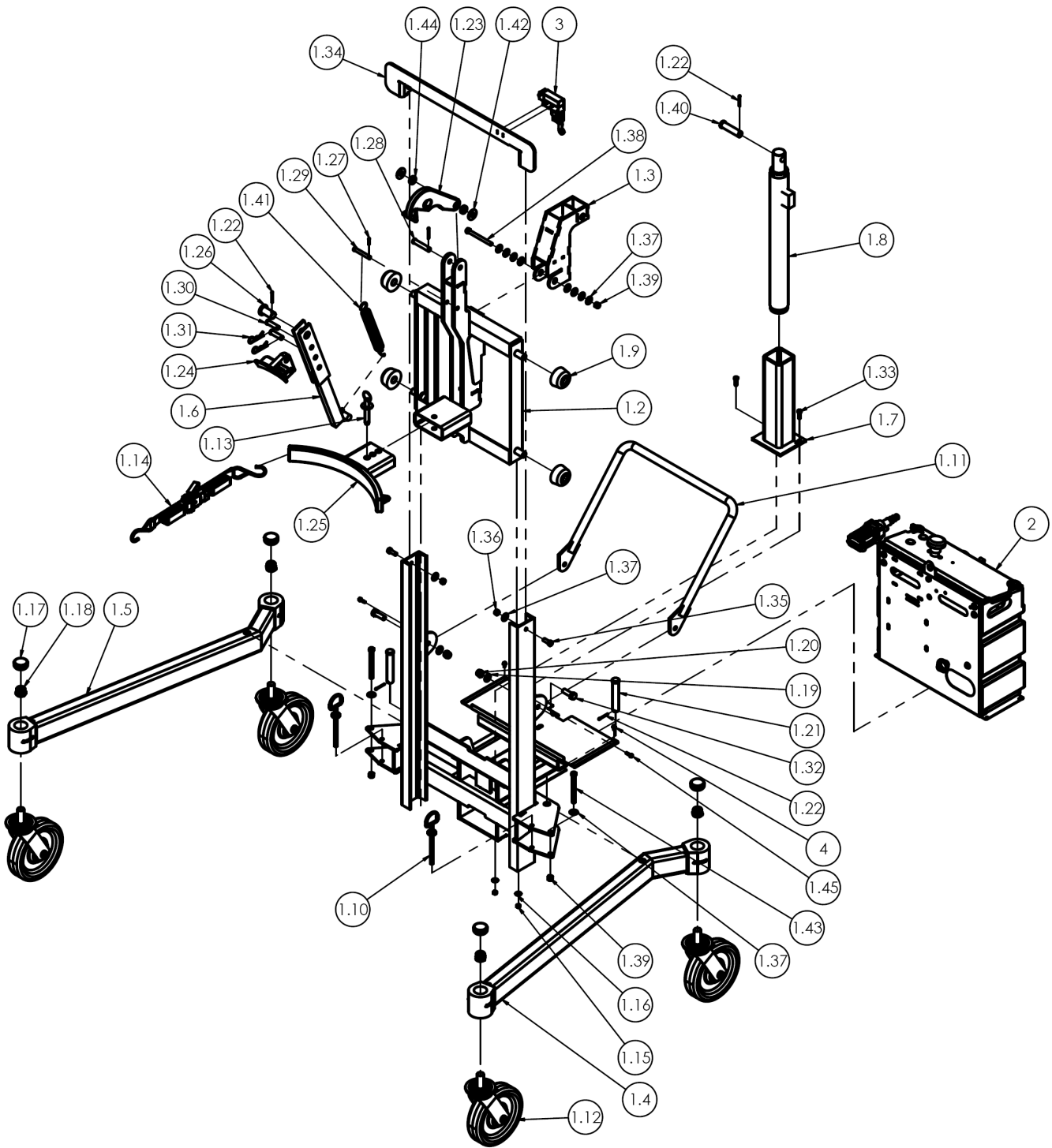

DCR-880-H-DC Bill of Materials

Item	Part no.	Description	Qty.	Item	Part no.	Description	Qty.
1	40-002-051	Final assembly w/o power	1	1.25	40-014-093	Frame, drum grip, casting	1
1.1	40-514-116	Weldment, frame	1	1.26	40-612-004	Pin, clevis	1
1.2	40-538-011	Weldment, carriage	1	1.27	65073	1/8" x 5/8" cotter pin	1
1.3	40-538-012	Weldment, carriage, cylinder bracket	1	1.28	40-112-016	Pin, upper casting mount	1
1.4	40-514-029	Weldment, leg, left	1	1.29	40-112-017	Pin, spring attach	1
1.5	40-514-030	Weldment, leg, right	1	1.30	21-112-003	Pin, 1/2"-13x1 1/2", retaining clevis	2
1.6	40-514-011	Weldment, frame	1	1.31	45286	#11 hitch pin clip, 1/8" x 2 5/8"	2
1.7	40-514-115	Weldment, cylinder mount	1	1.32	11209	Bolt, 1/2"-13x1 1/2" HHCS ASTM A307 grade A, zinc-plated	4
1.8	40-021-001	Cylinder, hydraulic, 1 1/2"-18", ram style, formed	1	1.33	11005	Hex bolt, 1/4"-20x1", HHCS #2, zinc-plated	2
1.9	21-527-003	Assembly, roller bearing	4	1.34	40-017-037	Stiffener, upper tie bar	1
1.10	40-537-001	Weldment, detent, leg position	4	1.35	11105	Hex bolt, 3/8"-16x1", grade A, zinc-plated	2
1.11	40-525-001	Weldment, handle	1	1.36	36106	Hex nut, grade A, zinc-plated, 3/8"-16	2
1.12	16-132-181	Stem caster, PH-F-8/2-S-STM	4	1.37	33008	Flat washer, low carbon, USS, zinc-plated, 3/8"	12
1.13	40-612-006	Weldment, pin, saddle retainer	1	1.38	11119	Hex bolt, grade A, zinc finish, 3/8"-16x4"	1
1.14	40-145-008	Strap with ratchet, 6' long, 2 hooks	1	1.39	37024	Nylon insert lock nut, grade 2, zinc finish, 3/8"-16	3
1.15	36102	Hex nut, grade A, zinc-plated, 1/4"-20	2	1.40	66170	Clevis pin, low carbon steel, plain, 3/4"x3"	1
1.16	33004	Flat washer, USS, zinc-plated, 1/4"	2	1.41	40-146-001	Spring, tension	1
1.17	99-024-003	Guard/cover/endcap/plug	4	1.42	33012	Flat washer, low carbon, z-finish, 1/2"	2
1.18	37039	Nylock nut, zinc-plated, 3/4"-10	4	1.43	11120	Hex bolt, gr. A, z-finish, 3/16"-16x4 1/4"	2
1.19	33011	Flat washer, USS, plain finish, 1/2"	2	1.44	21-113-030	Spacer, 1/4" length	2
1.20	37030	Nylon insert lock nut, 1/2"-13	2	1.45	32106	#12-24x 1/8" drill and tap screw	2
1.21	28-112-031	3/4" x 4 1/2" clevis pin	2	2	99-160-097	Modular power unit (MPU), Gen2	1
1.22	65078	Extended prong cotter pin, zinc finish, 1/8" x 1 1/2" cotter pin, zinc-plated	5	3	01-022-001	Limit switch with roller arm	1
1.23	40-016-052	Bracket, casting	1	4	31802	Screw, self-tapping	2
1.24	40-016-053	Bracket, casting, FMDL series	1				

*Units built after Dec. 1, 2018, receive 2nd generation modular power units (MPU-GEN2).

DCR-880-H-DC Standard Features

- Capacity = 1,500 lb.
- Frame height = 43 5/8"
- Maximum overall height = 53 9/16"
- Maximum overall length = 49 7/8"
- Minimum overall length = 43 9/16"
- Minimum inside width = 30 1/4"
- Maximum inside width = 61 7/16"
- Lowered jaw height = 30 7/8"
- Raised jaw height = 48 7/8"
- Casters = 8"x2" swiveling
- Minimum overall width = 37 3/4"
- Maximum overall width = 68 15/16"
- Net weight = 298 lb.
- DC power-operated carriage

DCR-880-H-HP-DC Exploded View (Bill of Materials on Following Page)

40-006-050

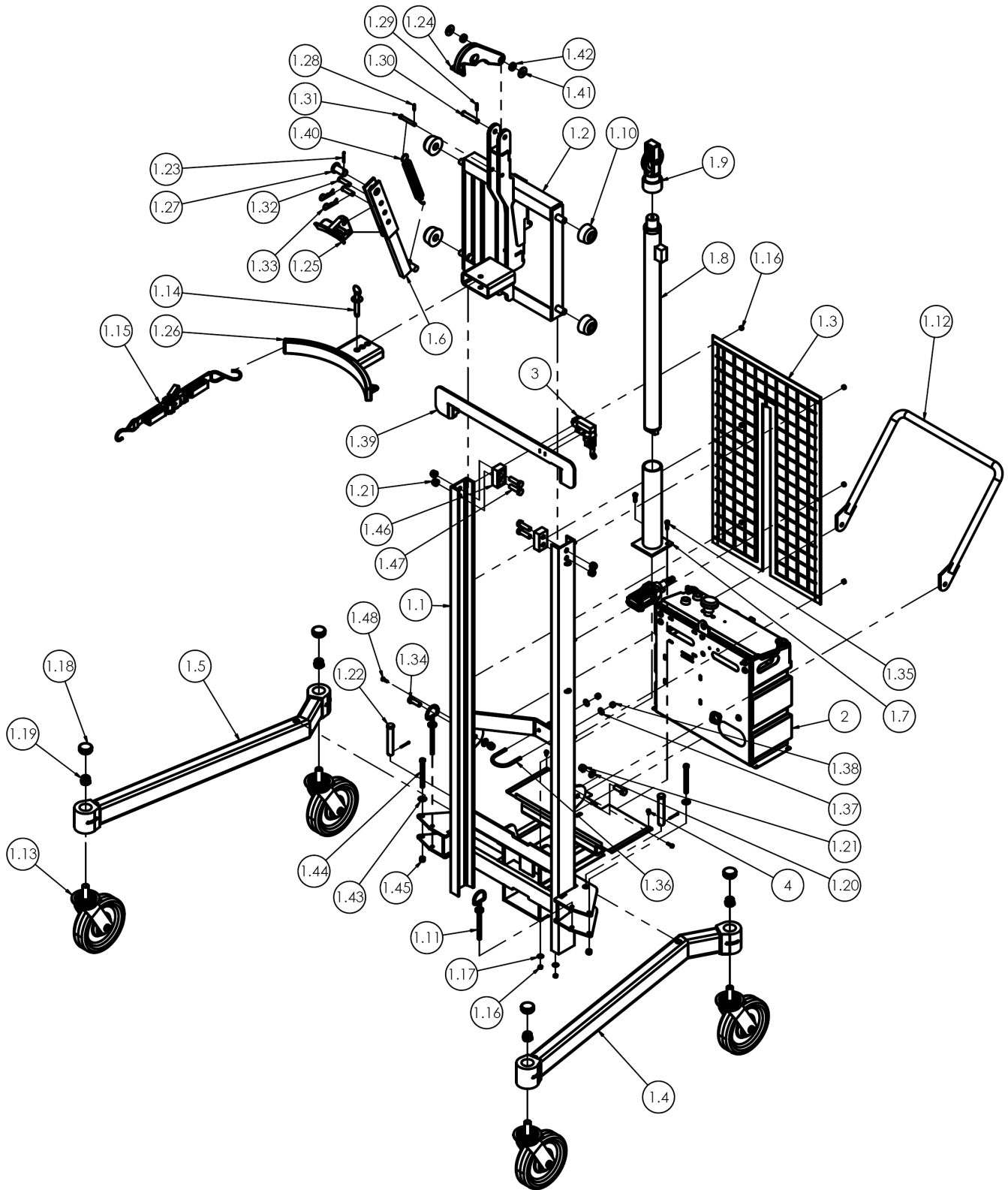

DCR-880-H-HP-DC bill of materials

Item	Part no.	Description	Qty.	Item	Part no.	Description	Qty.
1	40-002-050	Final assembly w/o power	1	1.27	40-612-004	Pin, clevis	1
1.1	40-514-064	Weldment, frame	1	1.28	65073	1/8" x 5/8" cotter pin	1
1.2	40-538-006	Weldment, carriage	1	1.29	65076	1/8" x 1" cotter pin, z-plated	1
1.3	40-524-001	Weldment, guard, pump	1	1.30	40-112-016	Pin, upper casting mount	1
1.4	40-514-029	Weldment, leg, left	1	1.31	40-112-017	Pin, spring attach	1
1.5	40-514-030	Weldment, leg, right	1	1.32	21-112-003	Pin, 1/2"-13x1 1/2", retaining clevis	2
1.6	40-514-011	Weldment, frame	1	1.33	45286	#11 hitch pin clip, 1/8" x 2 5/8"	2
1.7	40-514-062	Weldment, cylinder mount	1	1.34	11209	Bolt, 1/2"-13x1 1/2" HHCS ASTM A307 grade A, zinc-plated	4
1.8	99-021-927-001	Cylinder, hydraulic, 1 1/2"-18", ram style, formed	1	1.35	11005	Hex bolt, 1/4"-20x1", HHCS #2, zinc-plated	2
1.9	40-027-003	Assembly, pulley	1	1.36	42034	U-bolt, z-plated, 5/16"-18x2" pipe size	1
1.10	21-527-003	Assembly, roller bearing	4	1.37	33006	Flat washer, z-plated, USS, 3/16"	2
1.11	40-537-001	Weldment, detent, leg position	4	1.38	37021	Nylon insert lock nut, Gr. 2, z-finish, 5/16"-18	2
1.12	40-525-001	Weldment, handle	1	1.39	40-017-037	Stiffener, upper tie bar	1
1.13	16-132-181	Stem caster, PH-F-8/2-S-STM	4	1.40	40-146-001	Spring, tension	1
1.14	40-612-006	Weldment, pin, saddle retainer	1	1.41	33012	Flat washer, low carbon, zinc finish, 1/2"	2
1.15	40-145-008	Strap with ratchet, 6' long, 2 hooks	1	1.42	21-113-030	Spacer, 1/4" length	2
1.16	36102	Hex nut, grade A, zinc-plated, 1/4"-20	2	1.43	33008	Flat washer, low carbon, USS, zinc-plated, 3/8"	2
1.17	33004	Flat washer, USS, zinc-plated, 1/4"	2	1.44	11120	Hex bolt, gr. A, z-finish, 3/16"-16x4 1/4"	2
1.18	99-024-003	Guard/cover/endcap/plug	4	1.45	37024	Nylon insert lock nut, grade 2, zinc finish, 3/8"-16	2
1.19	37039	Nylock nut, zinc-plated, 3/4"-10	4	1.46	03-037-001	Stop block, wheel	2
1.20	33011	Flat washer, USS, plain finish, 1/2"	4	1.47	12210	Hex bolt, gr. 5, plain, 1/2"-13x1 3/4"	4
1.21	37030	Nylon insert lock nut, 1/2"-13	2	1.48	32106	#12-24 x 7/8" drill & tap screw	2
1.22	28-112-031	3/4" x 4 1/2" clevis pin	2	1.49	33-542-003	Chain, chain assembly	1
1.23	65078	Extended prong cotter pin, zinc finish, 1/8" x 1 1/2" cotter pin, zinc-plated	6	2	99-160-097	Modular power unit (MPU), Gen2	1
1.24	40-016-052	Bracket, casting	1	3	01-022-001	Limit switch with roller arm	1
1.25	40-016-053	Bracket, casting, FMDL series	1	4	31802	Screw, self-tapping	2
1.26	40-014-093	Frame, drum grip, casting	1				

*Units built after Dec. 1, 2018, receive 2nd generation modular power units (MPU-GEN2).

DIMENSION TOLERANCE ± 1/4"
 1" = 2.54cm 2.2 lb. = 1kg

DCR-880-H-HP-DC Standard features

Capacity = 880 lb.	Minimum inside width = 30 1/4"	Minimum overall width = 37 3/4"
Frame height = 72 1/8"	Maximum inside width = 61 7/16"	Maximum overall width = 68 15/16"
Maximum overall height = 81 7/16"	Lowered jaw height = 34 1/2"	Net weight = 302 lb.
Maximum overall length = 49 7/8"	Raised jaw height = 76 13/16"	Foot pump operated carriage
Minimum overall length = 43 9/16"	Casters = 8"x2" swiveling	

DC modular power unit exploded view and bill of materials

*Units built after Dec. 1, 2018, receive 2nd generation modular power units (MPU-GEN2).

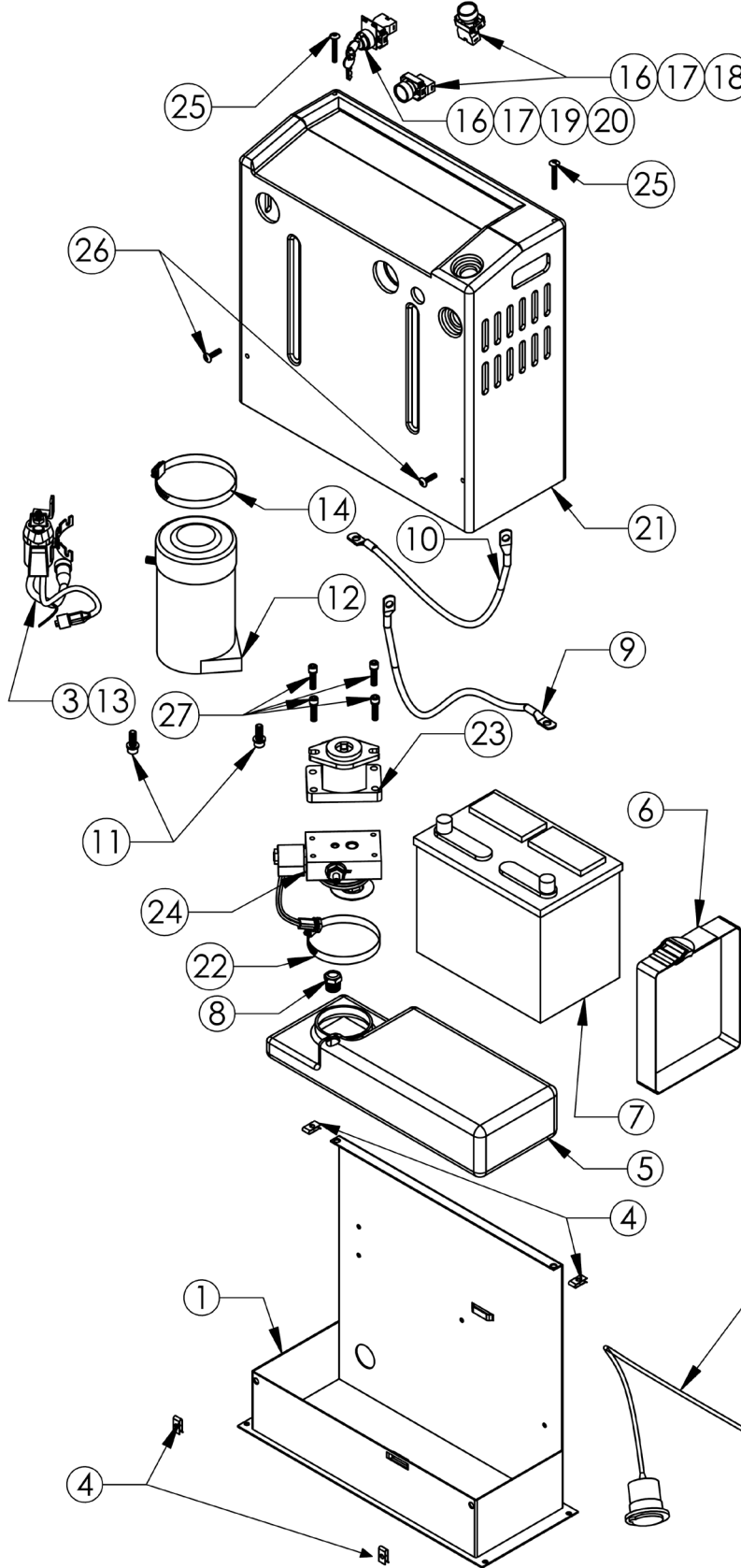

Item	Part no.	Description	Quantity
1	99-016-933	Base bracket	1
2	21-034-008	Charger (Soniel)	1
3	01-033-024	24", 18/3, 4-pin plug	1
4	37927	Tinnerman clip	4
5	99-023-001	Reservoir	1
6	99-034-013	Battery strap	1
7	24DC36	Battery	1
8	BV-48	Breather	1
9	15-533-013	Cable, battery, 23" black	1
10	15-533-014	Cable, battery, 23" red	1
11	23305 33688 33008	³ / ₈ " - 16 x 1" utility grade bolt ³ / ₈ " high collar lock washer ³ / ₈ " flat washer	2 2 2
12	99-135-011	4", 12VDC motor w/ tang dr.	1
13	15-022-004	12V start solenoid relay	1
14	HS64	Worm gear hose clamp	1
15	BG-12V	Battery gauge	1
16	ZB2BZ009	Base, contact block	3
17	ZB2BE101	Contact block N.O.	3
18	ZB2BA2C	Operator, black, non-illuminated	2
19	ZB2BG4C	Key switch, 2-position	1
20	01-134-007	Legend, ON - OFF	1
21	091802JY	Fiberglass cover	1
22	HS52	Clamp, worm gear	1
23	01-143-906	Pump	1
24	01-627-010	Manifold assembly (exploded view on p. 12)	1
25	29201	¹ / ₄ in. - 20 x ¹ / ₄ in. TPHMS zinc-plated	2
26	29185	¹ / ₄ in. - 20 x 1in. TPHMS zinc-plated	2
27	23255 33687	SHCS utility grade High collar lock washer	4 4
28	152400-03	Molded cord	1
29	150CCTM.OEM	Connector, charge	1
30	3MT ST3540	1in. hook and loop press	10"

Exploded view of DC manifold assembly (item no. 24 on p.14)

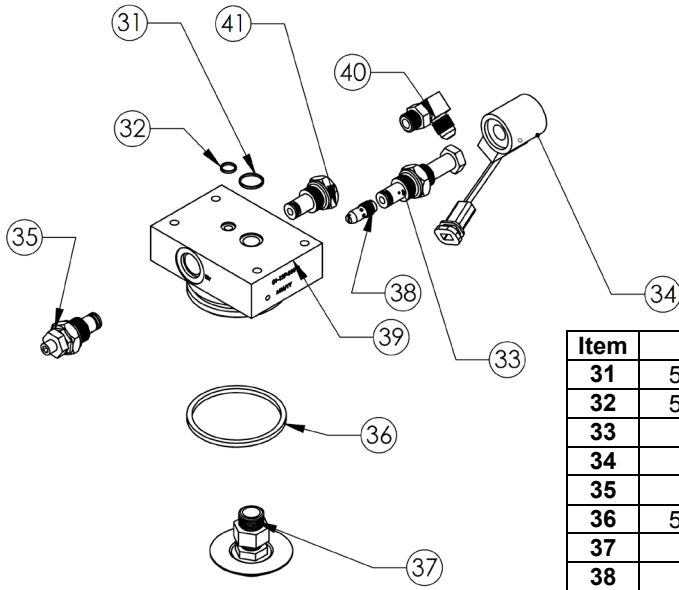

*Units built after Dec. 1, 2018, receive 2nd generation modular power units (MPU-GEN2).

Item	Part no.	Description	Qty.
31	568-015-BN70	O-ring	1
32	568-011-BN70	O-ring	1
33	99-153-058	Valve, cartridge, normally closed	1
34	99-034-010	Coil with weather-tite plug	1
35	99-153-006	Valve, pressure relief	1
36	568-334-BN70	O-ring	1
37	99-531-005	Filter	1
38	99-153-038	Flow control, 1.0GPM	1
39	01-127-010	Manifold	1
40	6801-06-06-NWO	MJ-MAORB 90 degree	1
41	99-153-011	Valve, check	1

12VDC modular power unit electrical circuit diagram

NOTES: Units built after Dec. 1, 2018, receive 2nd generation modular power units (MPU-GEN2).
Overcurrent & short-circuit protection and system disconnect must be provided.

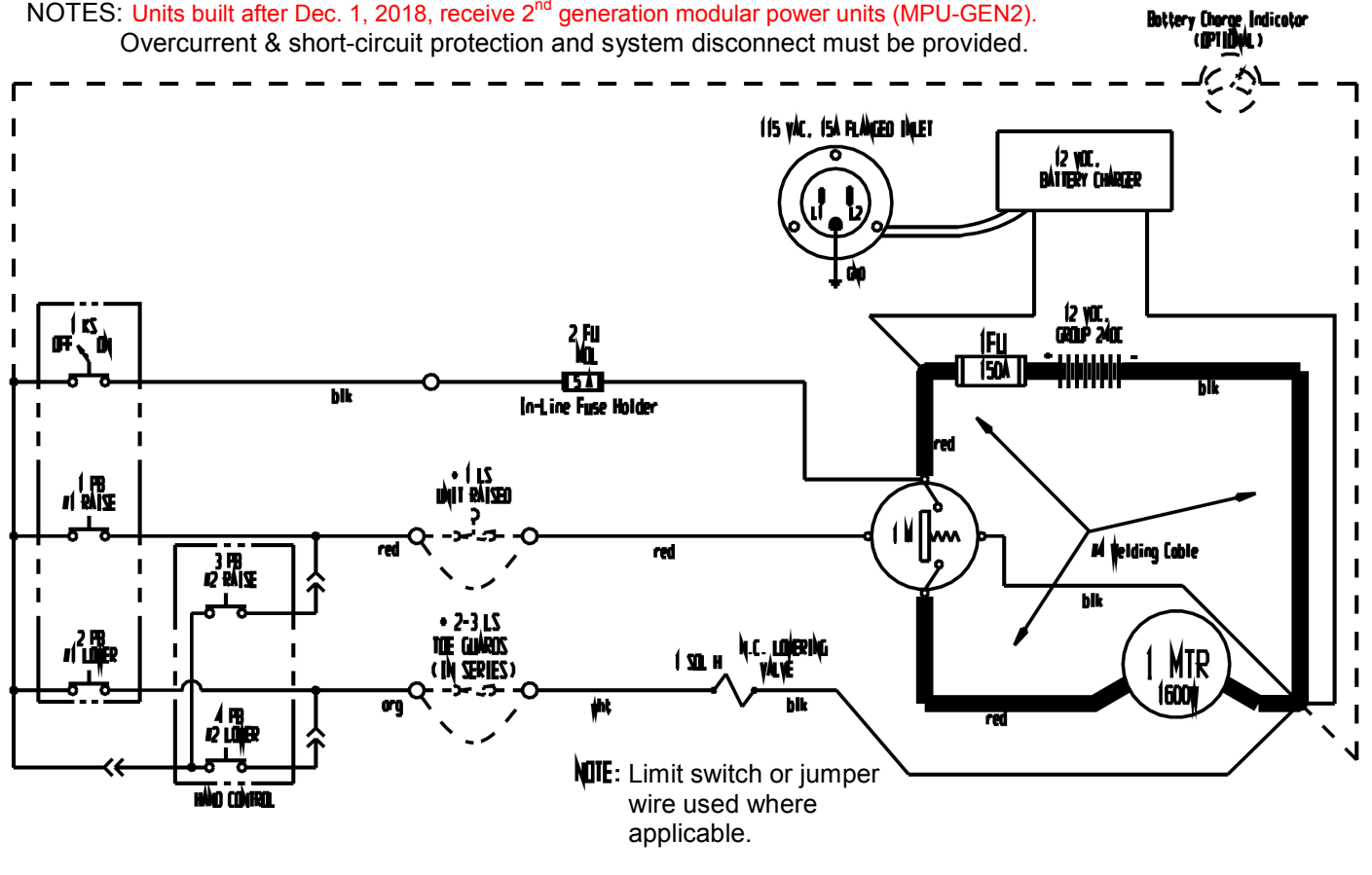

12VDC modular power unit layout (part 1 of 2)

NOTE: Units built after Dec. 1, 2018, receive 2nd generation modular power units (MPU-GEN2).

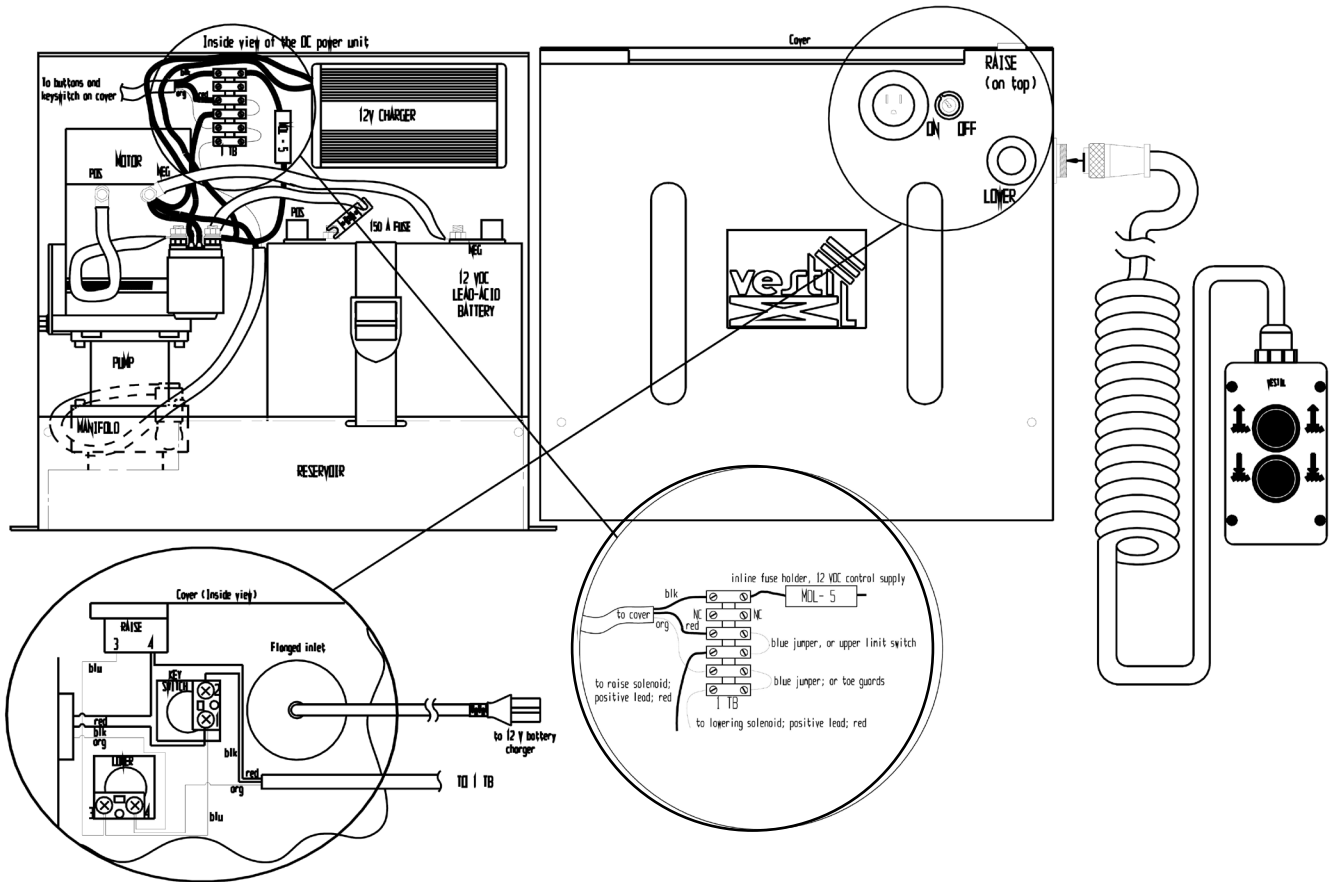

12VDC modular power unit layout (part 2 of 2)

NOTE: Units built after Dec. 1, 2018, receive 2nd generation modular power units (MPU-GEN2).

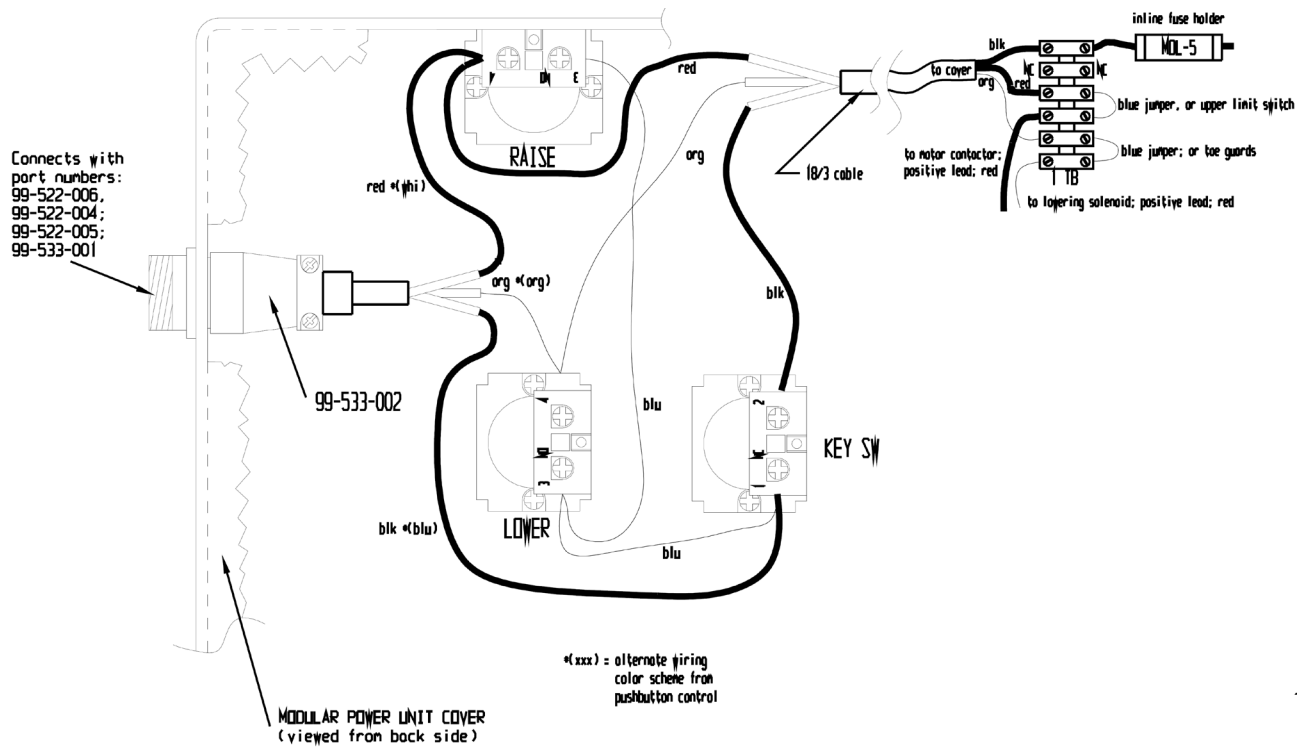

RECORD OF SATISFACTORY CONDITION (THE “RECORD”)

Thoroughly inspect the carrier before putting it into service. Record the condition and appearance of each of the frame members, fasteners, and casters/wheels. Thoroughly photograph the carrier from multiple angles. Include close range photographs of all labels, fasteners, and the drum gripping mechanism. Add the photographs to the record. Collate all photographs and writings into a single file. This file is a record of the carrier in satisfactory condition. Visually inspect all parts of the unit at least once per month. Compare your observations to the Record to determine whether the rack is in satisfactory condition. Do not use the carrier unless it is in satisfactory condition. Purely cosmetic changes, like damaged paint or powdercoat, are not changes from satisfactory condition. However, touchup paint should be applied as soon as damage occurs.

USING THE DRUM LIFTER (ALL MODELS)

DCR-series drum carriers are designed to handle 55-gallon steel, plastic, and fiber drums with lids. Three models, DCR-880-M, DCR-880-H, and DCR-880-H-HP, are manually operated. Model DCR-880-M uses a ratcheting jack that raises and lowers the carriage. The drum carriage of models DCR-880-H and DCR-880-H-HP is driven by a hydraulic cylinder extended and retracted by a foot pump.

DCR-880-M (Mechanical Ratcheting Jack)

NOTE: For the jack to operate optimally, move the handle all-the-way up and all-the-way down with each stroke. “Short jacking” occurs when the handle is not moved through its full range. Short jacking damages the teeth of the jack slide and can also damage the ratchet mechanism.

1. To raise the carriage: The direction selector must be in the “UP” position (see “Ratchet direction selector” below; selector shown in UP position). Raise the jack handle and press it down until you hear a click. Move the handle back-and-forth until the carriage rises to the necessary elevation.

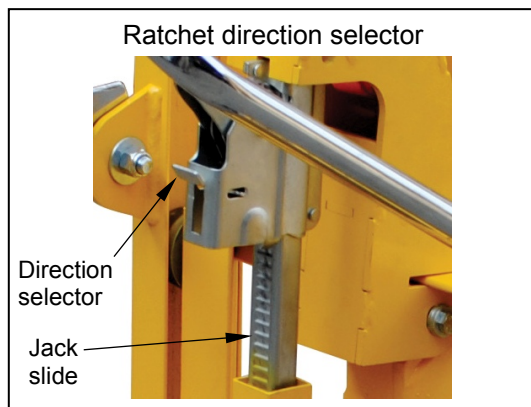

2. To lower the carriage: Press the direction selector down. Then, move the jack handle up and down until the carriage reaches the desired height.

DCR-880-H and DCR-880-H-HP (Hydraulic Foot Pump)

Press down on the treadle to extend the cylinder. When the treadle is released it returns to its starting position. Pump the treadle to raise the carriage and elevate the drum. To lower the carriage, step on the release lever on the side of the foot pump. Pressing the release lever opens a lowering valve. When the valve opens, the cylinder retracts and causes the carriage to lower. Descent can be stopped at any time simply by taking your foot off of the release lever. The carriage will maintain position until either the release lever or the treadle is pressed again.



LIFTING DRUMS

Only use the drum handler on level, even, improved surfaces (i.e. concrete or asphalt) capable of supporting the combined weight of the handler and a full capacity load. The capacity of your unit is the maximum load it can lift. Capacities for every model appear in the sections titled "Specifications" on pages 4, 6, 8, 10, and 12. Each unit is also labeled with its capacity. Refer to label 287 in the [Labeling diagram](#) on p. 24.

Adjust leg position: The legs are adjustable to be able to access drums on pallets. Each leg has 2 positions. To change leg position, pull the inner pin (see FIG. A below) out of the pin holes in the frame. Pivot the leg as necessary and reinsert the pin to secure the leg in its new position.



FIG. A: Leg positions

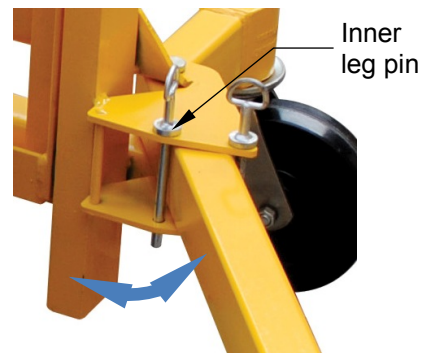

Engage the drum: Position the unit close to the drum so that the legs extend around it. Adjust the elevation of the carriage to bring the rim gripper into contact with the rim of the drum.

1. DCR-880-M: Use the jack to position the carriage. Be sure that the direction selector is in the UP position.
2. DCR-880-H & DCR-880-H-HP: Use the foot treadle and release lever to bring the gripper into proper position.
3. DCR-880-H-DC & DCR-880-H-HP-DC: Confirm that the battery has adequate charge; then use the control buttons to adjust the position of the gripper.

The support bracket should contact the bottom of the lid rim. Rotate the drum hook forward so that it rests on the top lid of the drum.

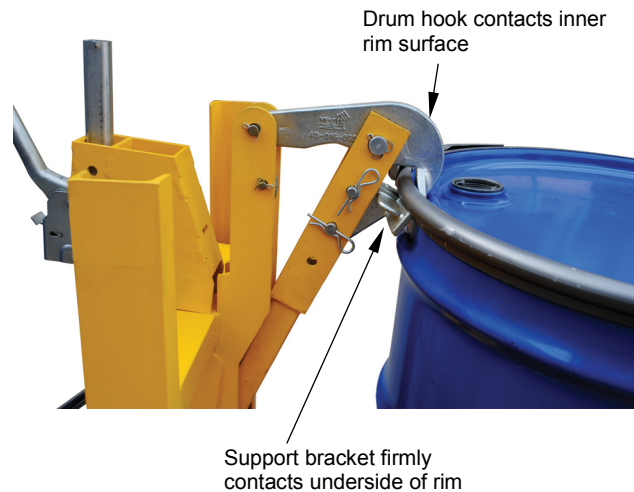

Strap the drum to the drum saddle: To press the drum firmly against the drum support. Wrap the ratchet strap around the drum and attach the hook at each end of the strap to the hook brackets on the drum saddle. Tighten the strap against the drum.



Drum saddle



Transport the drum: Elevate the drum only a few inches above the ground while transporting it.

Hydraulic Circuit Diagram – DCR-880-H and DCR-880-H-HP

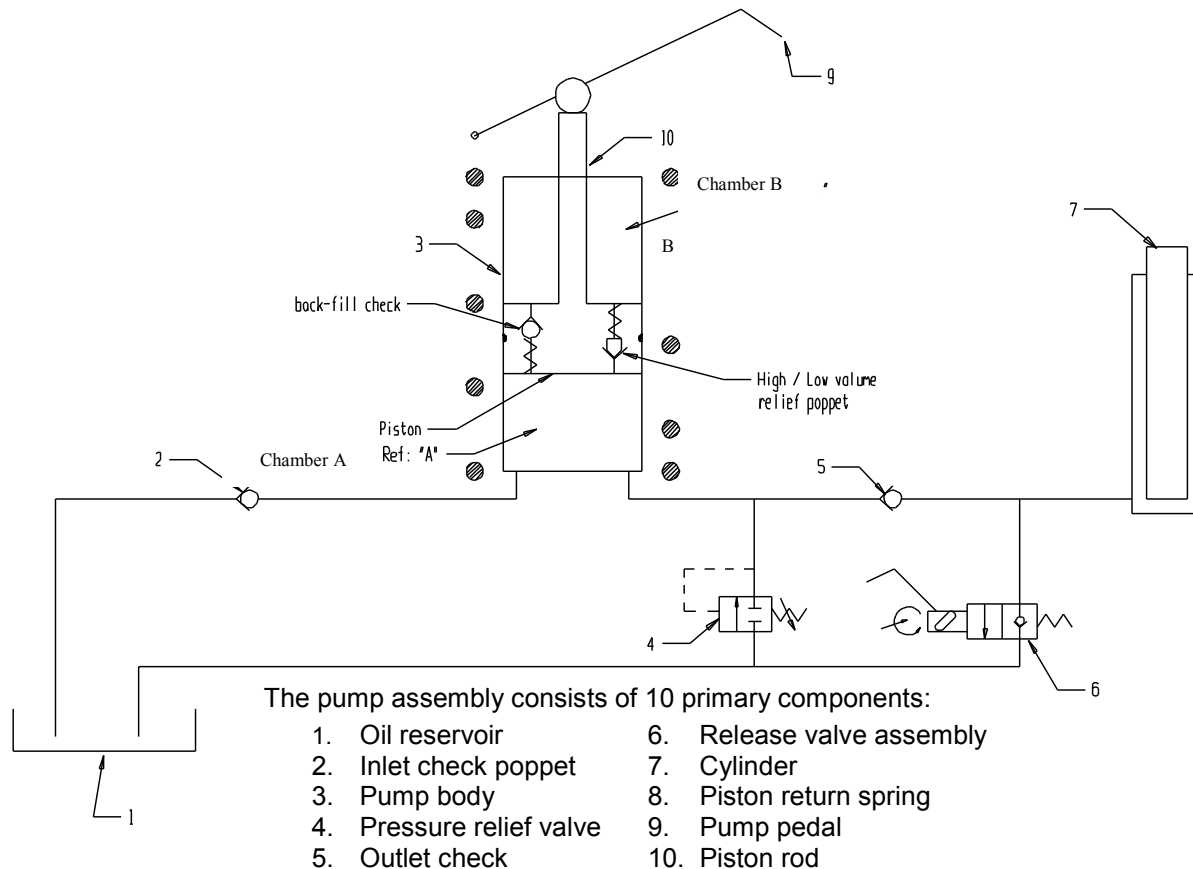

The pump assembly consists of 10 primary components:

- | | |
|--------------------------|---------------------------|
| 1. Oil reservoir | 6. Release valve assembly |
| 2. Inlet check poppet | 7. Cylinder |
| 3. Pump body | 8. Piston return spring |
| 4. Pressure relief valve | 9. Pump pedal |
| 5. Outlet check | 10. Piston rod |

The piston assembly incorporates a two-speed mechanism comprised of five main components:

- | | |
|----------------------------------|---|
| 1. Piston blind-side – Chamber A | 4. High-volume / low-volume relief poppet |
| 2. Rod-side – Chamber B | 5. Piston rod |
| 3. Back-fill check | |

MANUAL HYDRAULIC SYSTEM SEQUENCE OF OPERATION

Raising the carriage

The sequence begins with the foot pedal in the neutral (“home”) position. The operator activates the hydraulic system by pressing the foot pedal down. This is referred to as the “power-stroke”. After releasing the foot pedal, the piston return spring (B) exerts an upward force on the piston. Oil flows from the reservoir, through the inlet check valve, and into chamber A. At the same time, oil trapped in chamber B from a prior cycle flows across the back-fill check into chamber A. When another power stroke occurs, the inlet check valve closes and prevents oil from flowing back into the reservoir. The outlet check valve simultaneously opens and oil flows into the cylinder. The piston return spring forces the piston and the foot pedal back to the home position and chamber A again fills with oil as the piston rises.

The pump has two modes of operation: 1) Low-pressure, high-volume and 2) High-pressure, low-volume.

1. Low Pressure, High Volume.

When raising an unloaded or lightly loaded platform, the pump operates in low-pressure mode. As the operator presses the foot pedal (power stroke):

- Back-fill check remains closed;
- High / low volume relief poppet remains closed; AND
- All oil in chamber A flows into the cylinder.

2. High Pressure, Low Volume

When raising a partly loaded or heavily loaded platform, the pump operates in high-pressure mode. During a power stroke:

- Back-check remains closed;
- High / low volume relief poppet opens;
- A volume of oil equal to the annulus (piston diameter minus the rod diameter) flows from A to B;
- Oil equal to the cross-sectional area of the rod flows to the cylinder; AND
- The force required to open the high / low volume relief poppet adds to the cylinder load resistance.

Pressure relief system

If a load that exceeds the maximum rated load is placed on the deck, or a mechanical malfunction interferes with the movement of the deck, the pressure relief valve will open during a power-stroke. The pressure relief valve reduces the likelihood that excessive loads will damage the lifter frame or the hydraulic system. The pressure relief valve shunts oil directly from chamber A to the reservoir.

Release valve assembly

The foot-actuated release valve assembly is the mechanism that allows the deck to lower. When the release pedal is pressed down, the release valve opens, and oil flows from the cylinder to the reservoir. The lowering rate is adjustable; instructions appear under [Release pedal adjustment](#) on p. 22. Lowering rate is also variable: the farther down the release pedal is pressed, the more rapidly the deck descends. The weight of a load on the deck affects the flow rate, and therefore, a heavier load will lower more rapidly than a lighter load, regardless of the lowering rate selected. When the operator lets the pedal loose, the release pedal tensioning spring returns the release pedal to the home position, which automatically closes the valve.

Hydraulic circuit diagram (DC-powered units; 01-127-010 Rev. C)

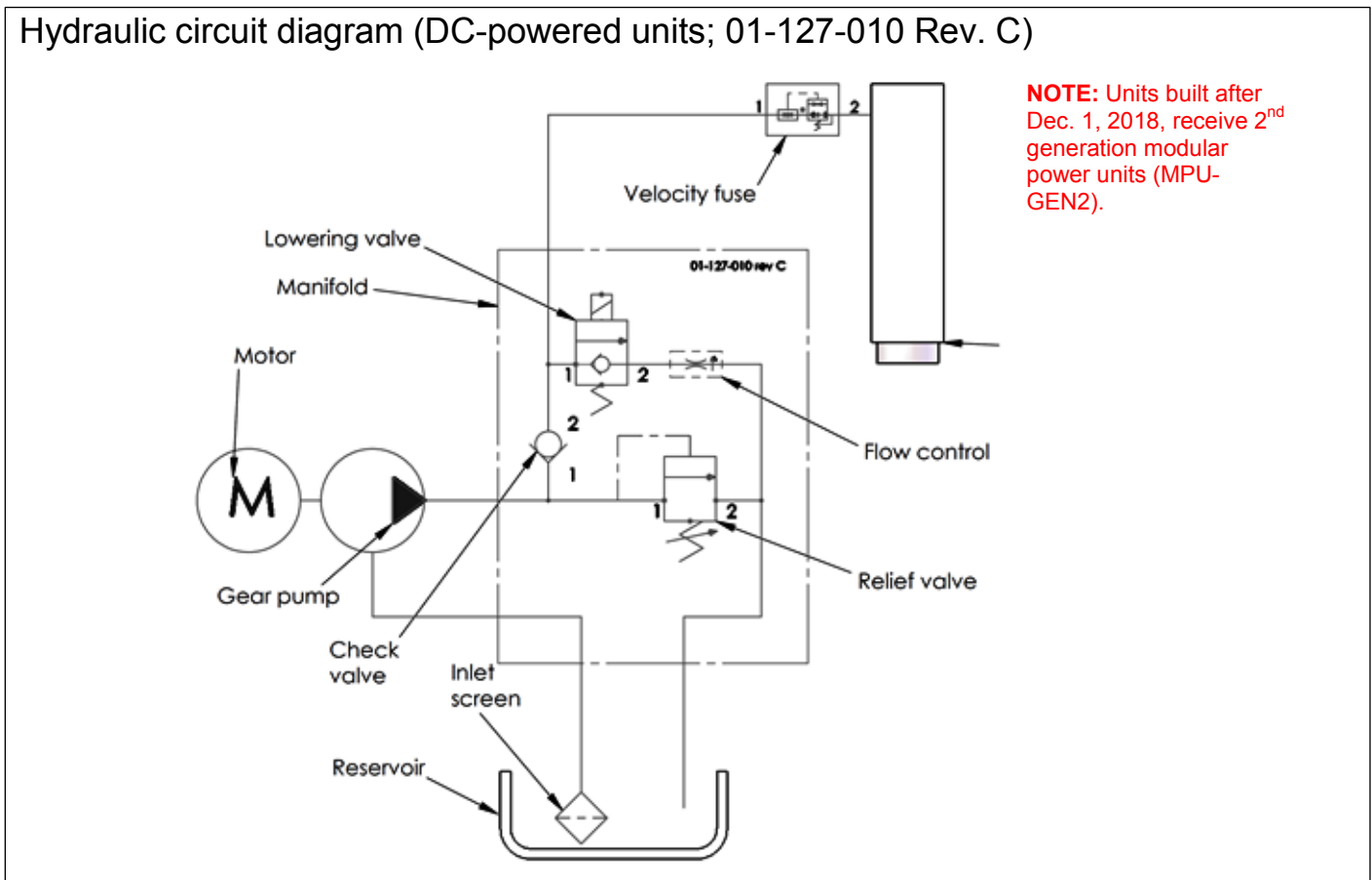

OPERATION INSTRUCTIONS FOR DC-POWERED UNITS (DCR-880-H-DC & DCR-880-H-HP-DC)

NOTE: Units built after Dec. 1, 2018, receive 2nd generation modular power units (MPU-GEN2). The MPU-GEN2 owner manual provides operation instructions.

The drum carriage of electrically powered units is controlled by a handheld controller as well as pushbuttons on the power unit housing. To raise or lower the carriage, press the appropriately marked button. When either button is released, the carriage will maintain position.

To raise the carriage, press the **UP** button on the pushbutton controller. This starts the electric motor which turns the hydraulic pump. Oil from the reservoir (inside the modular power unit) flows through a suction filter and into the pump. The pump delivers pressurized oil to the hydraulic cylinder through a check valve. The check valve allows oil to flow only in one direction, i.e. to the cylinders, and prevents oil from flowing back into the pump circuit when the pump stops. This traps oil in the cylinder causing the carriage to maintain elevation after the control button is released.

If a load exceeds the capacity of the lifter, pressure will build up in the circuit between the pump and the cylinders when the **UP** button is pressed. This pressure forces the relief valve to unseat which in turn allows oil to circulate back

to the reservoir rather than pushing it into the cylinder. This pressure relief mechanism prevents damage to the hydraulic system.

To lower the carriage, press the **DOWN** button. This energizes the lowering solenoid valve coil, which unseats the poppet valve and allows oil to return to the reservoir from the cylinder through the pressure-compensated flow control valve. Releasing the **DOWN** button de-energizes the solenoid and closes the valve poppet. The poppet valve and check valve together prevent oil from returning to the reservoir and cause the cylinders to stop retracting. The carriage will maintain its position until another command is received.

LOWERING SOLENOID VALVE

The lowering valve might occasionally need to be cleaned. See “Troubleshooting” on p. 23-24. Before working on any part of the hydraulic system, always lower the carriage.

1. Remove the cover from the power unit.
2. Identify the lowering valve (port LL in the manifold) and remove it.
3. Use a thin tool to press the poppet in (from the bottom of the valve) and open the valve.
4. Repeat several times while immersing the valve in kerosene or mineral spirits.
5. Blow compressed air through the valve while holding it open as described in step 3.
6. Inspect the O-rings and the PTFE washer (polytetrafluoroethylene). If either component is damaged, replace it.
7. Reinstall the valve. The valve should be tightened to approximately 20 ft.-lb. of torque.

VELOCITY FUSE

There is a brass velocity fuse with a stainless steel spring in the base of the cylinder. This safety feature reduces the possibility of personal injury and damage to the DCR (or load) if there is a sudden loss of hydraulic pressure. If a fitting leaks or a hose is punctured, the platform lowers more rapidly. If the rate of descent exceeds the preset speed of the velocity fuse, the fuse closes. While the fuse is shut oil cannot flow. The carriage remains stationary until pressure is reestablished.

The velocity fuse might activate although no failure occurs, if, for instance, air enters the hydraulic system. To be able to raise or lower the carriage requires resetting the velocity fuse. To reset the fuse, activate the pump by jogging the **UP** button. Immediately after resetting the velocity fuse, lower the carriage and remove the drum. Then, cycle the carriage by raising the carriage all the way up and back down. Do this several times to purge air from the system.

BLEEDING AIR FROM THE HYDRAULIC CIRCUIT

If the carriage descends very slowly or not at all, air probably is trapped in the hydraulic circuit and must be bled from the system. To bleed air from the hydraulic circuit, follow these directions.

- 1.) Lower the carriage. If applicable, also disengage the drum.
- 2.) A “bleeder” screw is located at the top of the cylinder. Loosen the bleeder screw by 1/4 to 1/2 turn to allow trapped air to escape. Jog the motor to push air out of the system.
- 3.) When the cylinder is free of air, only clear hydraulic fluid will flow from the bleeder screw opening. At that point, retighten the bleeder screw.

USING THE BATTERY CHARGER (DC UNITS ONLY)



WARNING Working on lead-acid batteries is dangerous. Batteries contain sulfuric acid and produce explosive gases. A battery explosion could result in loss of eyesight or serious burns.

- DO NOT smoke near the battery or expose the battery to a spark or flame.
- ONLY charge batteries in dry, well-ventilated locations.
- DO NOT lay metallic items, like tools, on top of a battery
- NEVER touch both terminals simultaneously! Remove personal jewelry items such as rings and watches.
- Always have plenty of fresh water and soap nearby in case contact with battery acid occurs.
- Operating the battery with low voltage can cause premature motor contact failure.
- The charger is equipped with an external ground wire (small green wire). During installation the charger must be grounded to the equipment. Be sure this wire is always connected to the chassis, frame, or other metallic surface considered to be ground.
- Remove accumulated deposits on the terminals and confirm that all battery connections are sound.
- Replace defective electrical cords and wires immediately.
- DO NOT use the charger if the flanged inlet is damaged.
- DO NOT connect the charger to a damaged extension cord.

Every DC powered drum carrier is equipped with an onboard battery charger with a flanged electrical inlet. The inlet is mounted through the cover/housing of the power unit. The user must provide a 3-prong charging cord appropriate for the line and motor voltages.

The charger is current limited and will not exceed its rated output even if loads are placed on the battery while it is charging. The charger fuse will blow if it is connected in reverse polarity. To charge the battery:

- 1.) Plug the charger into a 115V, 60 Hz receptacle by connecting the flanged inlet on the charger to an extension cord. Plug the other end of the cord into a wall socket. Use a short, thick extension cord to minimize voltage drop between the wall receptacle and the charger.
- 2.) When properly connected, the charge LED will indicate the status of charge current flowing to the battery.
 - If only the red LED is on, the charger is providing full output to the battery.
 - If both the red and green LED's are on, the charger is "topping off" the battery.
 - When only the green LED is on, the unit is providing a "float" (maintenance) charge.
 - DO NOT leave the charger on for long periods after the battery is fully charged.
- 3.) Unplug the charger before using the lifter to avoid damaging cords, receptacles, etc.

CHARGER TROUBLESHOOTING

If the charger does not work:

- 1) Make sure all battery connections sound.
- 2) Confirm that the AC power source (e.g. wall socket) is supplying power.
- 3) Examine the fuse (see p. 15). Replace only with a fuse having the same rating as the original fuse.
- 4) Determine battery condition. It may take some time before current begins to flow through a highly sulfated battery.

INSPECTIONS & MAINTENANCE

Regular maintenance is required to keep this product in nominal condition.

- Relieve hydraulic pressure whenever the unit is not in use by fully lowering the carriage.
- Keep the product clean & dry. Lubricate moving parts at least once per month.
- If repairs are necessary, only install manufacturer-approved replacement parts. Vestil is not responsible for issues or malfunctions that result from the use of unapproved replacement parts.
- ONLY use ISO AW-32 hydraulic fluid or its equal in the hydraulic system. Do not use brake fluid or jack oils in the hydraulic system. If oil is needed, use an anti-wear hydraulic oil with a viscosity grade of 150 SUS at 100°F, (ISO 32 cSt @ 40°C), or Dexron transmission fluid.

Before using the DCR for the first time, make a written record of its appearance. Include observations about each component, being particularly detailed about the carriage and rim-grasping parts. Raise and lower the carriage. Include observations about how the unit sounds as the carriage moves, how much effort is required to move the jack handle or foot treadle, or how the unit responds to pushbutton signals. This record establishes "normal condition". During future inspections, compare the appearance of the unit to the written record to determine if it is in normal condition. DO NOT use the FDT unless it is in normal condition.

(A) Before Each Use--Inspect the following:

1. Wiring: inspect the electrical wiring for cuts and frays.
2. Casters: examine the casters. Casters should be solidly fastened to the frame. Look for areas of severe wear and damage. Each caster should roll smoothly without wobbling.
3. Hydraulic hoses: check for pinches, punctures, or loose connections.
4. Structure: inspect the legs and frame for cracked welds, bends, etc.
5. Carriage and mast: observe the carriage as it cycles up and down the mast. Make note of unusual noise and motion (e.g. binding).
6. Pushbutton controller and modular power unit (MPU): inspect the controller and look for damage that exposes internal components.

(B) Monthly Inspections--at least once per month check the following:

1. Oil level. Oil should be 1" to 1-1/2" below the top of the tank with the lift in the fully lowered position. Add as necessary. Look for oil leaks, i.e. from hoses, the cylinder, or the reservoir.
2. MPU, hand control, and battery (DC models only): Remove the cover of the MPU and visually inspect the components. Check the water level in the battery. Check for worn or damaged hydraulic hoses, electrical wires, and cords. Repair as necessary.
3. Clevis pins and pivot points: inspect for excessive wear.
4. Cylinder: extend and retract the cylinder. It should not be bent, cracked, etc.
5. Carriage roller bearings (see [Exploded View](#) on p. 3; 5; 7; 9; and 11): check rollers and retaining hardware for normal condition.
6. Carriage and mast: cycle the lift function up (to the top) and back down while listening and watching for unusual noise, motion, or binding.
7. Labels (shown in [Labeling diagram](#); p. 24): confirm that all labels are in place and in good, readable condition.
8. Surfaces: wash the unit to remove dirt and debris.

(C) Yearly Inspection

Hydraulic oil should be changed at least once a year or sooner if the oil darkens or becomes gritty. Flush the reservoir

before refilling. Similarly, if the oil appears milky, water is present and the oil should be changed. If oil is needed, use HO150 hydraulic fluid. Any anti-wear hydraulic fluid with a viscosity grade of 150 SUS at 100° F (ISO 32 @ 40° C) such as AW 32 or Dexron transmission fluid is acceptable.

TROUBLESHOOTING: DCR-880-H & -HP

Lower and unload the carriage before beginning service work on the unit. Purge all hydraulic pressure from the foot pump by holding the release open for two seconds once the drum is lowered to the floor.

If the pump malfunctions in any of the following ways:

- Cylinder rod fails to extend while pumping the foot treadle;
- Cylinder rod rises and lowers with each stroke of the foot pump treadle; or
- Carriage descends on its own.

Try each of the following fixes until the pump works properly

1. Hydraulic fluid level adjustment:

- Fully lower the carriage by pressing the release lever and holding it down.
- Remove the fill/breather plug and insert a clean, flexible object, like a cable tie, wire, or twist tie, down inside the cylinder to determine the oil level. The oil surface should be approximately 2" below the fill hole. If oil is needed, use HO150 hydraulic fluid. Any anti-wear hydraulic fluid with a viscosity grade of 150 SUS at 100° F (ISO 32 @ 40° C) such as AW 32 or Dexron transmission fluid is acceptable.

2. Flush contamination from the check assemblies. Press the release pedal down as far as it will go while pumping the foot treadle rapidly. This will create turbulence inside the pump, which might dislodge contamination that might be preventing one of the check balls from seating properly.

3. Release pedal adjustment

- Loosen the release pedal screw retaining nut.
- Loosen the pedal screw $\frac{1}{2}$ to a full counterclockwise turn using either a hex key wrench (Allen wrench) or a flat blade screw driver.
- Grasp an empty drum with the drum gripping mechanism and pump the foot pedal until the drum rises several inches above the ground. Press the release pedal. If the drum lowers, turn the screw another $\frac{1}{2}$ counterclockwise turn. Raise the drum again. Continue this process until the drum maintains elevation. The drum should not lower when the release pedal is pressed.
- Turn the release pedal screw clockwise $\frac{1}{8}$ to $\frac{1}{4}$ turn. Press the release lever. The drum should lower now. If it does not, turn the screw clockwise by another $\frac{1}{8}$ turn and again press the release pedal. Continue this process until the desired lowering speed is achieved.
- Tighten the retaining nut. To prevent the screw from rotating at the same time, either hold the screw with your fingers or use the hex wrench or screwdriver into the fitting.

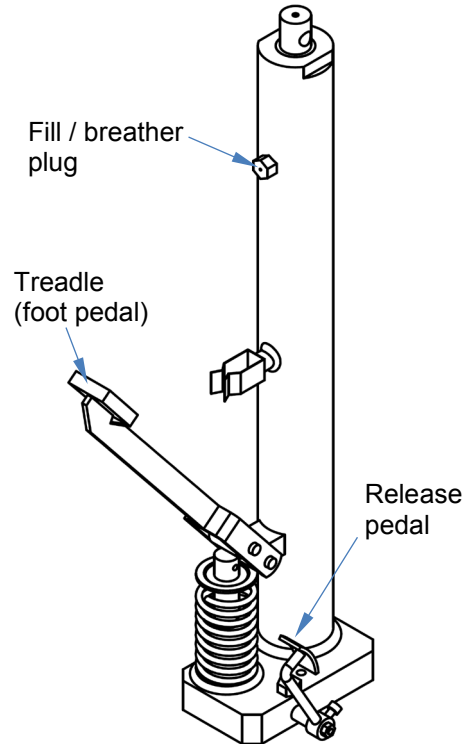
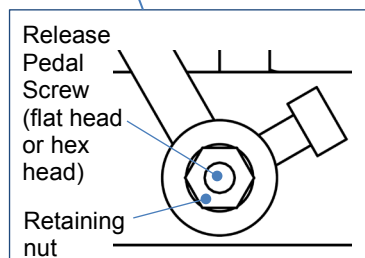
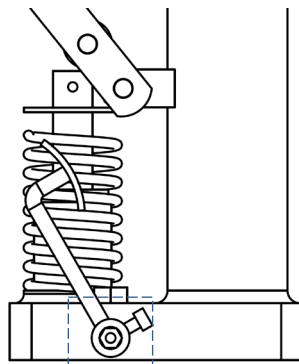

4. Clean the Inlet Check Valve Assembly

- Remove inlet check port plug with a crescent wrench and remove the valve.
- Clean the valve components.
- While the valve is disassembled, pump the foot pedal 5 or more times. Fluid will discharge from the port, which should dislodge debris clogging the valve.
- Reassemble the valve & reconnect the port plug.
- Add hydraulic fluid as necessary according to the "Hydraulic Fluid Level Adjustment" instructions above.

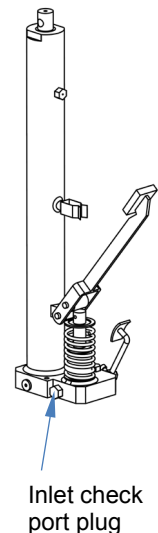

TROUBLESHOOTING: DCR-880-H-DC & DCR-880-H-HP-DC

Contact technical support for assistance resolving issues not addressed in the guide.

Issue	Possible Cause	Remedy
1. Carriage does not rise and motor does not run	a. Low battery voltage. (Check light) b. All chassis connections to negative post of battery not made well.	a. Recharge battery b. Check and tighten or clean connections if necessary.
2. Carriage does not rise but motor is running or humming.	c. Voltage at motor terminals might be too low to run pump at existing load. d. Fluid level in reservoir is low. e. Load exceeds capacity requirements. Relief valve is allowing hydraulic fluid to flow back into the reservoir. f. Suction filter is clogged, starving pump. g. Suction line fittings are loose allowing air to enter. h. Filter/Breather cap on tank is clogged. i. Lowering solenoid valve might be energized by faulty wiring or might be stuck open. j. Hydraulic pump not operating.	c. Measure voltage at motor terminals (as near as possible) while pump runs under load. Check for loose wiring connections. d. Add fluid. (See p. 16 for proper fluid level.) e. DO NOT CHANGE RELIEF VALVE SETTING. Instead, reduce the load to rated capacity. f. Remove filter and clean. g. Inspect all fittings for proper tightness. h. Remove cap and clean. i. Remove lowering solenoid valve. Check and clean. Refer to Lowering Solenoid Valves on p. 20. j. Disconnect hydraulic line from power unit. Put pressure line in a large container and operate the pump. If no output, check the pump motor coupling and correct as appropriate. If pump is worn, contact factory for replacement parts.
3. Carriage rises too slowly.	k. Foreign material stuck in lowering solenoid valve causing fluid to flow back into the reservoir. l. Foreign material clogging suction filter or breather cap, or a hose is pinched. m. Low motor voltage. n. Unit overloaded. o. Inoperative pump.	k. Lower the carriage. Remove the lowering solenoid valve and clean. Refer to p. 20. l. Correct as appropriate. (See also, 2(f), (h). m. See 1 (b) n. See 2 (e) o. See 2 (j)
4. Motor labors or is extremely hot.	p. Battery voltage too low. q. Oil starvation causing pump to bind & overheat. [NOTE: If this occurs, pump can be permanently damaged.] r. Binding cylinder.	p. See 1 (b) q. See 2 (d), (f), (g), (h), (j) r. Align cylinder correctly.
5. "Spongy" carriage rises in jerks or is spongy when elevated.	s. Fluid starvation. t. Air in system.	s. See 2 (d), (f), (g), (j) t. See air bleeding procedure (p. 17).
6. Carriage lowers too slowly when loaded.	u. Lowering solenoid valve filter screen clogged. v. Pinched tube or hose. w. Foreign material in flow control valve. x. Binding cylinders. y. Foreign material in velocity fuse.	u. Remove lowering solenoid valve and clean filter screen. v. Correct as appropriate. w. Remove and clean flow control valve. Refer to Hydraulic Circuit Diagram on p. 19. x. Align cylinders correctly. y. Remove and clean velocity fuse. Refer to Hydraulic Circuit Diagram on p. 19.
7. Carriage lowers too quickly.	z. Foreign material stuck in flow control valve. (In this case, carriage initially lowers at a normal rate but accelerates as the carriage descends).	z. Remove flow control valve from the valve block and clean. Refer to Hydraulic Circuit Diagram on p. 19.
8. Carriage rises then lowers slowly on its own.	aa. Lowering solenoid valve may be incorrectly wired or is stuck open bb. Check valve stuck open. cc. Leaking hoses, fittings, pipes. dd. Cylinder packing is worn or damaged.	aa. See 3 (k). bb. Remove and clean check valve. cc. See 2 (c). dd. Replace packing. Contact factory for replacement parts .
9. Carriage elevates but does not lower.	ee. Incorrect lowering solenoid valve wiring. ff. Lowering solenoid valve is stuck. gg. Faulty lowering solenoid coil.	ee. Correct per diagram (p. 19). ff. Lightly tap down the solenoid coil body to seat it properly. (DO NOT hit coil hard as it will permanently damage the internal system. DO NOT remove the solenoid valve from the block because the carriage will descend dangerously quickly.) gg. Remove and replace. DO NOT remove the

	<p>hh. Binding cylinders. ii. Air present in the hydraulic system causing the velocity fuse to activate</p>	<p>lowering solenoid valve from the block because the carriage will lower in an uncontrolled manner. hh. See 4 (r). ii. To unlock, pressurize the hydraulic system.</p>
--	---	---

LABELING DIAGRAM

Label content and location are subject to change so your product might not be labeled exactly as shown. Compare the diagram below to your *Record of Satisfactory Condition*. If there are any differences between actual labeling and this diagram, contact *Technical Service*.

Replace all labels that are damaged, missing, or not easily readable (e.g. faded). To order replacement labels or to inquire whether your unit is properly labeled, contact the technical service and parts department online at http://www.vestilmfg.com/parts_info.htm or by calling (260) 665-7586 and asking for the Parts Department.



A: Label 287

MODEL/MODÉLO/MODÈLE _____
STATIC CAPACITY (evenly distributed) _____ lbs.
LA CAPACIDAD CONSTANTE (distribuida uniformemente) _____ kgs.
CAPACITÉ STATIQUE (distribuée régulièrement) _____ kgs.
SERIAL/SERIE/SÉRIE _____

287 REV 0812

B: Label 643

⚠ WARNING	⚠ ADVERTENCIA	⚠ AVERTISSEMENT
KEEP CLEAR OF PINCH POINT	MANTENGASE ALEJADO DEL PUNTO DE CORTE	SE TENIR À DISTANCE DU POINT DE PINCEMENT
VESTIL MANUFACTURING CORPORATION • Phone (260) 665-7586 • Fax (260) 665-1339 • sales@vestil.com • www.vestil.com		

C: Label 206 (on base frame by foot pump or inside MPU on oil tank)

ISO 32 / 150 SUS
HYDRAULIC OIL OR NON-SYNTHETIC TRANSMISSION FLUID
ACEITE HIDRAULICO O LIQUIDOS DE TRANSMISION NO SINTETICOS
HUILE OU LIQUIDE HYDRAULIQUE NON-SYNTHÉTIQUE
206 Rev. 1003
VESTIL MANUFACTURING CORPORATION • Phone (260) 665-7586 • www.vestil.com

D: Label 820

⚠ WARNING	⚠ ADVERTENCIA
Material handling is inherently dangerous. Reduce the likelihood of causing serious personal injuries through misuse by applying the following: • Use proper lifting techniques • Keep feet and body clear when using • Drum needs to be in good working condition	La manipulación de materiales es inherentemente peligrosa. Reduzca la probabilidad de causar graves lesiones al personal por el mal uso mediante la aplicación de lo siguiente: • Use técnicas de elevación correctas • Mantenga los pies y el cuerpo alejado cuando en uso • El tambor tiene que estar en buenas condiciones de uso
820	

DCR-880-H-DC & DCR-880-H-HP-DC also have the following label 295 applied to the modular power unit

Label 295 (on MPU cover)

⚠ WARNING
Enclosed battery contains hazardous chemicals. DO NOT handle enclosed battery UNLESS wearing eye protection and other appropriate personal protective equipment. DO NOT directly contact skin with battery. DO NOT expose to sparks or extreme heat; battery contains explosive gases.
⚠ ADVERTENCIA
La batería incluida contiene materiales peligrosos. NO use la batería incluida A NO SER que lleve protección de ojos y otros equipos de protección apropiados para el personal. NO tenga contacto directo en la piel con la batería. NO exponga a destellos o a calor excesivo, la batería contiene gases explosivos.

295 rev 0111

LIMITED WARRANTY

Vestil Manufacturing Corporation (“Vestil”) warrants this product to be free of defects in material and workmanship during the warranty period. Our warranty obligation is to provide a replacement for a defective, original part covered by the warranty after we receive a proper request from the Warrantee (you) for warranty service.

Who may request service?

Only a warrantee may request service. You are a warrantee if you purchased the product from Vestil or from an authorized distributor AND Vestil has been fully paid.

Definition of “original part”?

An original part is a part used to make the product as shipped to the Warrantee.

What is a “proper request”?

A request for warranty service is proper if Vestil receives: 1) a photocopy of the Customer Invoice that displays the shipping date; AND 2) a written request for warranty service including your name and phone number. Send requests by one of the following methods:

<u>US Mail</u>	<u>Fax</u>	<u>Email</u>
Vestil Manufacturing Corporation 2999 North Wayne Street, PO Box 507 Angola, IN 46703	(260) 665-1339 <u>Phone</u> (260) 665-7586	info@vestil.com Enter “Warranty service request” in subject field.

In the written request, list the parts believed to be defective and include the address where replacements should be delivered. After Vestil receives your request for warranty service, an authorized representative will contact you to determine whether your claim is covered by the warranty. Before providing warranty service, Vestil will require you to send the entire product, or just the defective part (or parts), to its facility in Angola, IN.

What is covered under the warranty?

The warranty covers defects in the following original, dynamic parts: motors, hydraulic pumps, motor controllers, and cylinders. It also covers defects in original parts that wear under normal usage conditions (“wearing parts”), such as bearings, hoses, wheels, seals, brushes, and batteries.

How long is the warranty period?

The warranty period for original dynamic components is 90 days. For wearing parts, the warranty period is 90 days. Both warranty periods begin on the date Vestil ships the product to the Warrantee. If the product was purchased from an authorized distributor, the periods begin when the distributor ships the product. Vestil may, at its sole discretion, extend a warranty period for products shipped from authorized distributors by up to 30 days to account for shipping time.

If a defective part is covered by the warranty, what will Vestil do to correct the problem?

Vestil will provide an appropriate replacement for any *covered* part. An authorized representative of Vestil will contact you to discuss your claim.

What is not covered by the warranty?

The Warrantee (you) is responsible for paying labor costs and freight costs to return the product to Vestil for warranty service.

Events that automatically void this Limited Warranty.

- Misuse;
- Negligent assembly, installation, operation or repair;
- Installation/use in corrosive environments;
- Inadequate or improper maintenance;
- Damage sustained during shipping;
- Collisions or other accidents that damage the product;
- Unauthorized modifications: Do not modify the product IN ANY WAY without first receiving written authorization from Vestil.

Do any other warranties apply to the product?

Vestil Manufacturing Corp. makes no other express warranties. All implied warranties are disclaimed to the extent allowed by law. Any implied warranty not disclaimed is limited in scope to the terms of this Limited Warranty. Vestil makes no warranty or representation that this product complies with any state or local design, performance, or safety code or standard. Noncompliance with any such code or standard is not a defect in material or workmanship.

