

# FORK LIFT HITCH - FTTM-2

APPROX WEIGHT: 44.57 lbs.  
DOES NOT INCLUDE WEIGHT OF POWER OR PACKAGING!!!

\*\*\* ANY ADDITIONS, DELETIONS, OR OMISSIONS MUST BE CORRECTED ON THIS DRAWING AS THIS DRAWING WILL BE CONSIDERED ALL INCLUSIVE \*\*\*

ALL GRAPHICS PROVIDED ARE FOR REFERENCE ONLY. IF CERTAIN DIMENSIONS ARE CRITICAL PLEASE VERIFY THOSE DIMENSIONS WITH YOUR SALESPERSON

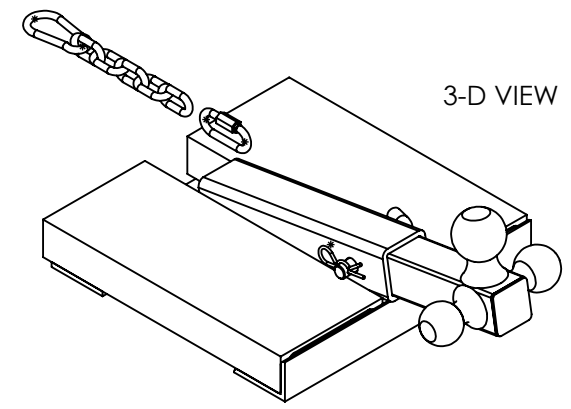
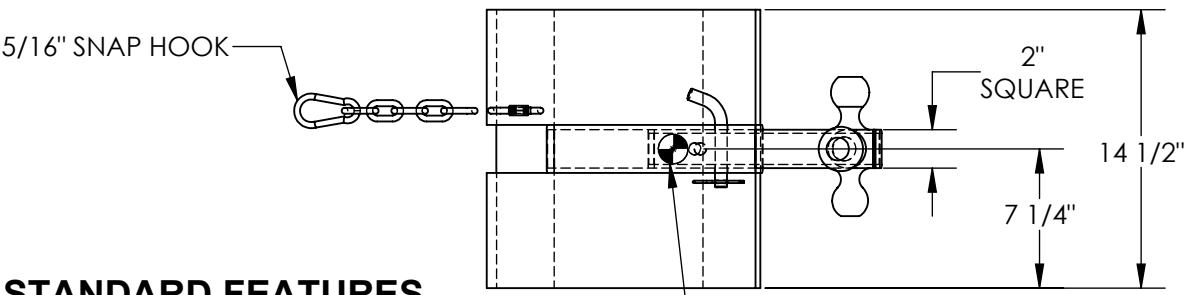
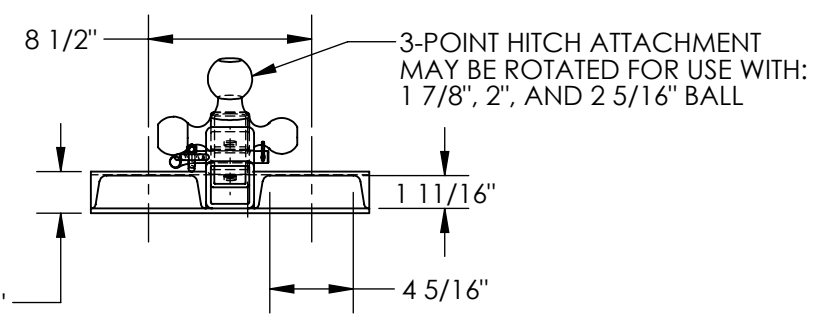
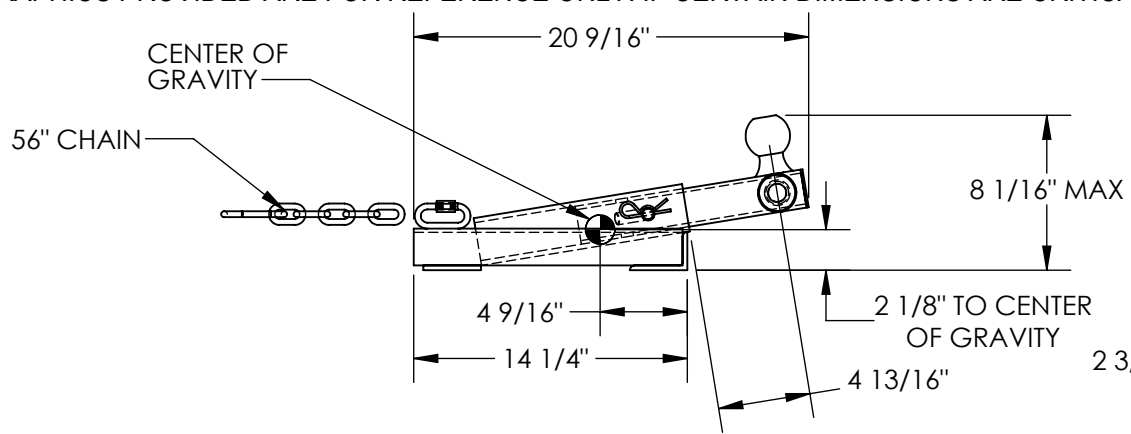

## STANDARD FEATURES

- MODEL NUMBER IS FTTM-2
- OVERALL WIDTH IS 14 1/2"
- OVERALL LENGTH IS 20 9/16"
- OVERALL HEIGHT IS 8 1/16" MAX
- LOST LOAD = 45 lbs.
- USABLE FORK POCKET = 4 5/16" x 1 11/16"
- 56" CHAIN INCLUDED
- 1,500 LB MAX TONGUE LOAD
- MAX PUSH CAPACITY FOR 1 7/8" BALL IS 2,000 LBS
- MAX PUSH CAPACITY FOR 2" BALL IS 3,500 LBS
- MAX PUSH CAPACITY FOR 2 5/16" BALL IS 7,500 LBS
- UNIT NOT INTENDED FOR PULLING (CHAIN LIMITS LOAD CAPACITY)

**SPECIAL FEATURES**  
NONE

NEVER EXCEED LOAD CENTER RATING PER FORK TRUCK MANUFACTURER'S GUIDELINES. DO NOT USE THIS FORK TRUCK ATTACHMENT IF LOAD WILL EXCEED FORK TRUCK MANUFACTURER'S LOAD CENTER RATING.  
\* OSHA REQUIRES ALL FORK LIFT ATTACHMENTS TO BE APPROVED BY THE FORK TRUCK MANUFACTURER. RELABELING OF FORK TRUCK MAY BE REQUIRED DUE TO CHANGES IN LOAD CENTERS. IT IS THE RESPONSIBILITY OF THE CUSTOMER TO GET PERMISSION FROM THE FORK TRUCK MANUFACTURER FOR USE ON THEIR SPECIFIC FORK TRUCKS.

DIMENSION TOLERANCE ± 1/4"

<b>APPROVAL</b>	I, THE UNDERSIGNED, AGREE THAT THE PRODUCT AS REPRESENTED SATISFIES DESIGN AND DIMENSION REQUIREMENTS. I ALSO ACKNOWLEDGE MY DUTY TO CONFIRM PRODUCT AND INSTALLATION COMPLIANCE WITH ALL APPLICABLE FEDERAL, STATE AND LOCAL REGULATIONS AND STANDARDS.	
	<b>ANY MODIFIED UNITS ARE NON-RETURNABLE</b>	
	[ ] As drawn      [ ] As marked	
	Signed: _____ Date: _____	
Printed Name: _____		
<b>LEAD TIME WILL START UPON RECEIPT OF SIGNED APPROVAL DRAWING</b>		

FOR INTERNAL USE ONLY PROJECT SIGN OFF	
SALES	
ENG.	
FAB.	
POWER	

DISTRIBUTOR'S NAME:		P.O.#
<b>VESTIL MANUFACTURING</b>		X
DRAWN BY: B. HORN		W.O.#
DATE: 04/03/15		X
REFERENCE: X	SCALE: 1:10	SALES: X
QUOTED LEAD TIME: X	QUOTE # X	FILE NAME:
		08-007-287