

PORTABLE GAS POWERED DRUM CRUSHER - HDC-900-GPT

ANY ADDITIONS, DELETIONS, OR OMISSIONS MUST BE CORRECTED ON THIS DRAWING AS THIS DRAWING WILL BE CONSIDERED ALL INCLUSIVE

APPROX WEIGHT: 2433.7076 lbs.

DOES NOT INCLUDE WEIGHT OF POWER OR PACKAGING!!!

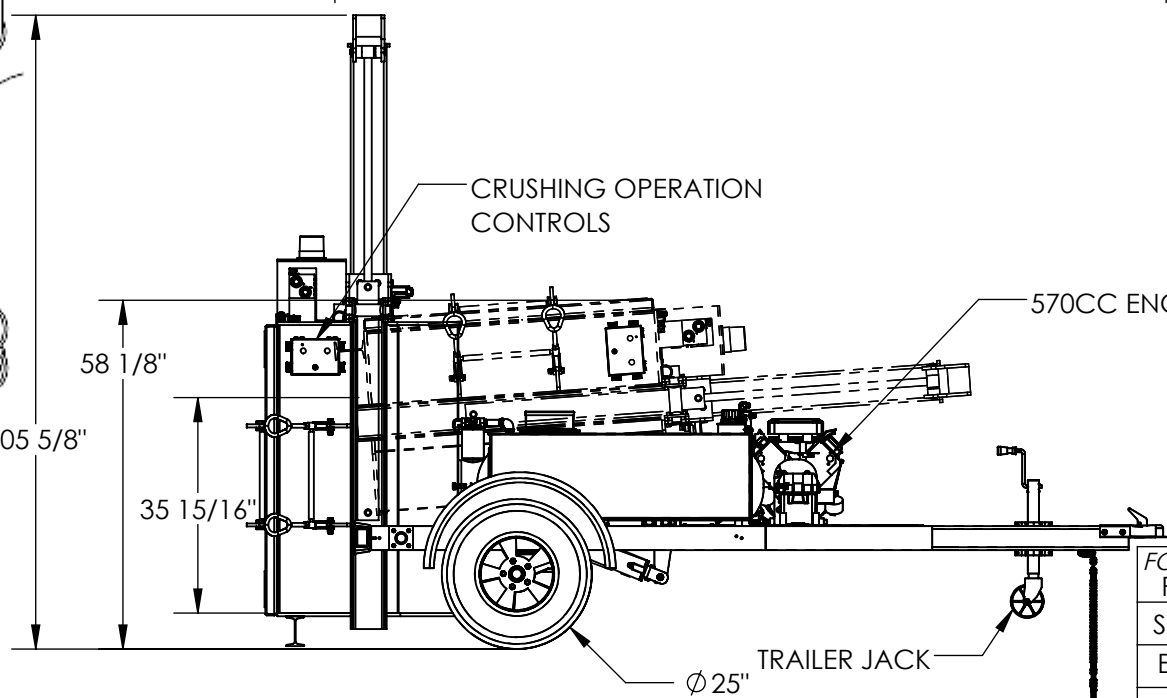
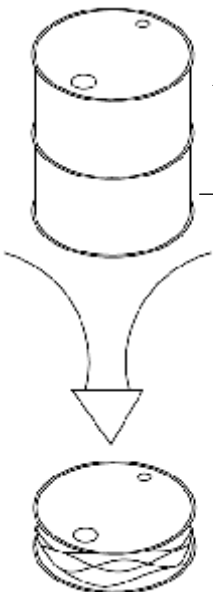
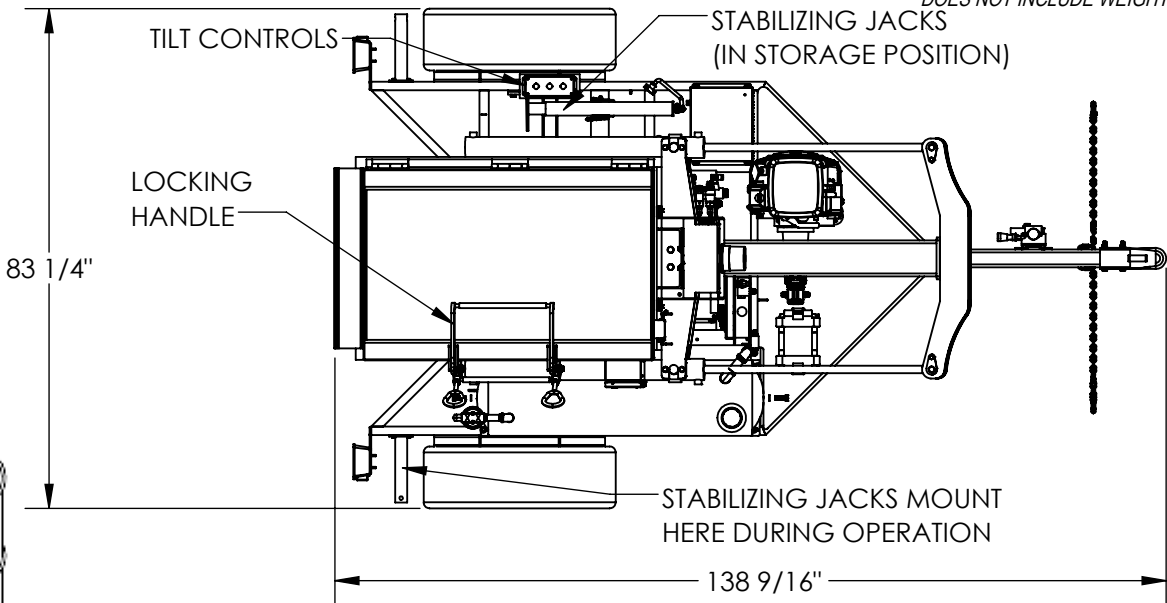

FOR INTERNAL USE ONLY PROJECT SIGN OFF	
SALES	
ENG.	
FAB.	
POWER	

ALL GRAPHICS PROVIDED ARE FOR REFERENCE ONLY. IF CERTAIN DIMENSIONS ARE CRITICAL PLEASE VERIFY THOSE DIMENSIONS WITH YOUR SALESPERSON

DIMENSION TOLERANCE ± 1/4"

STANDARD FEATURES

- MODEL NUMBER IS HDC-900-GPT
- CAPACITY IS (1) 55 GALLON DRUM
- OVERALL WIDTH IS 83 1/4"
- OVERALL LENGTH (TRANSPORT) IS 138 9/16"
- OVERALL HEIGHT IS 105 5/8"
- OVERALL HEIGHT (TRANSPORT) IS 58 1/8"
- USABLE HEIGHT IS 35 15/16"
- 570CC BRIGGS & STRATTON GASOLINE ENGINE
- DURABLE LIQUID PAINT BLUE FINISH

CUSTOMER IS RESPONSIBLE FOR TITLING, REGISTERING, AND PLATING THIS PRODUCT IF REQUIRED BY YOUR STATE MOTOR VEHICLE AUTHORITY.

SPECIAL FEATURES

NONE

APPROVAL

I, THE UNDERSIGNED, AGREE THAT THE PRODUCT AS REPRESENTED SATISFIES DESIGN AND DIMENSION REQUIREMENTS. I ALSO ACKNOWLEDGE MY DUTY TO CONFIRM PRODUCT AND INSTALLATION COMPLIANCE WITH ALL APPLICABLE FEDERAL, STATE AND LOCAL REGULATIONS AND STANDARDS.

UNITS REQUIRING APPROVAL DRAWINGS OR MODIFIED ARE NON-RETURNABLE

[] As drawn [] As marked

Signed: _____ Date: _____

Printed Name: _____

LEAD TIME WILL START UPON RECEIPT OF SIGNED APPROVAL DRAWING

DISTRIBUTOR'S NAME:		P.O.#
VESTIL MANUFACTURING		X
DRAWN BY: KGH		DATE: 10/19/2020
REFERENCE: X		SCALE: 1:32
QUOTED LEAD TIME: X		QUOTE # X
		W.O.# X
		SALES: X
		FILE NAME:
		22-007-014