

HEAVY DUTY DRUM LIFTER - HDDL-55

APPROX WEIGHT: 44.56 lbs.
 DOES NOT INCLUDE WEIGHT OF POWER OR PACKAGING!!!

*** ANY ADDITIONS, DELETIONS, OR OMISSIONS MUST BE CORRECTED ON THIS DRAWING AS THIS DRAWING WILL BE CONSIDERED ALL INCLUSIVE ***

ALL GRAPHICS PROVIDED ARE FOR REFERENCE ONLY. IF CERTAIN DIMENSIONS ARE CRITICAL PLEASE VERIFY THOSE DIMENSIONS WITH YOUR SALESPERSON

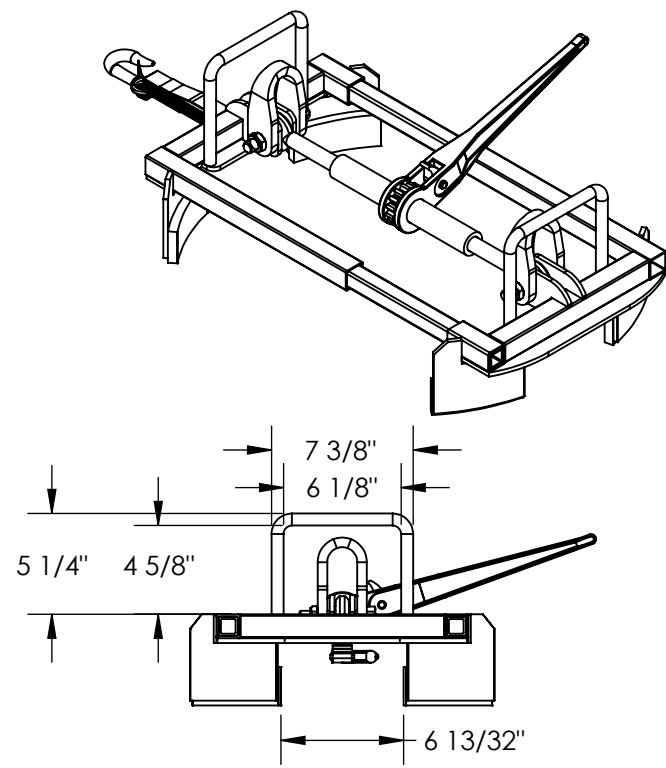
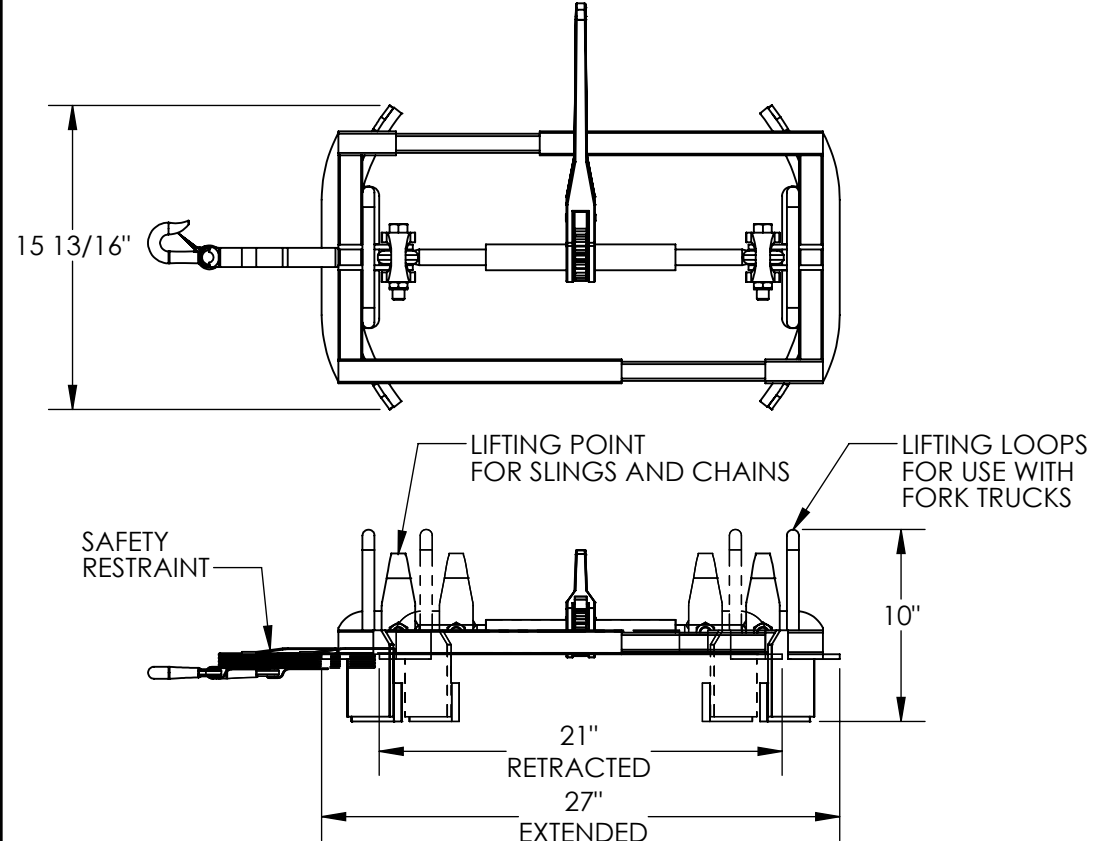

STANDARD FEATURES

- MODEL NUMBER IS HDDL-55
- OVERALL WIDTH IS 15 13/16"
- EXTENDED LENGTH IS 27"
- RETRACTED LENGTH IS 21"
- OVERALL HEIGHT IS 10"
- MAX CAPACITY IS 1500 LBS.
- DESIGNED FOR LIFTING 55 GAL. CLOSED-HEAD DRUMS IN THE VERTICAL POSITION
- INTEGRAL LOOPS INCLUDED FOR USE WITH FORK TRUCK FORKS/TINES
- USABLE FORK POCKET HEIGHT IS 4 5/8"
- USABLE FORK POCKET WIDTH IS 6 1/8"
- INCLUDES LIFTING POINTS FOR ATTACHING SLINGS OR CHAINS
- INCLUDES SAFETY RESTRAINT

SPECIAL FEATURES

NONE

DIMENSION TOLERANCE ± 1/4"

I, THE UNDERSIGNED, AGREE THAT THE PRODUCT AS REPRESENTED SATISFIES DESIGN AND DIMENSION REQUIREMENTS. I ALSO ACKNOWLEDGE MY DUTY TO CONFIRM PRODUCT AND INSTALLATION COMPLIANCE WITH ALL APPLICABLE FEDERAL, STATE AND LOCAL REGULATIONS AND STANDARDS.

ANY MODIFIED UNITS ARE NON-RETURNABLE

As drawn As marked

Signed: _____ Date: _____

Printed Name: _____

LEAD TIME WILL START UPON RECEIPT OF SIGNED APPROVAL DRAWING

DISTRIBUTOR'S NAME:		P.O.#
VESTIL MANUFACTURING		X
DRAWN BY: TJM		W.O.#
DATE: 06/10/11		X
REFERENCE: X	SCALE: 1:10	SALES: X
QUOTED LEAD TIME: X	QUOTE #	FILE NAME:
	X	09-007-143

FOR INTERNAL USE ONLY PROJECT SIGN OFF	
SALES	
ENG.	
FAB.	
POWER	