

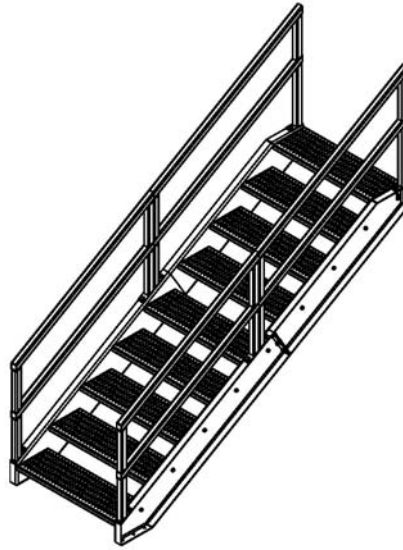

INSTRUCTION MANUAL
 MODEL "STAIR" MODULAR STYLE STAIRWAY



VESTIL MANUFACTURING CORP.

2999 NORTH WAYNE STREET, P.O. BOX 507, ANGOLA, IN 46703

TELEPHONE: (260) 665-7586 -OR- TOLL FREE (800) 348-0868

FAX: (260) 665-1339

URL: WWW.VESTILMFG.COM EMAIL: SALES@VESTIL.COM

TABLE OF CONTENTS

SAFETY PRINCIPLES.....	2
PRODUCT DESCRIPTION.....	2
EXPLODED PARTS DIAGRAM & PARTS LIST.....	3
HARDWARE (FASTENERS).....	4
ASSEMBLY INSTRUCTIONS.....	5-6
INSTALLATION INSTRUCTIONS.....	6-7
▪ MEASUREMENTS & WALL AND FLOOR MARKINGS.....	6
▪ PREPARE THE FLOOR.....	7
▪ PREPARE THE WALL.....	7
INSPECTIONS & MAINTENANCE.....	8

TABLE OF FIGURES

FIG. 1A	ASSEMBLY STEP 1.....	5
FIG. 1B	ASSEMBLY STEP 1 (ADDITIONAL CONNECTIONS REQUIRED FOR MULTI-SECTION MODELS).....	5
FIG. 2	ASSEMBLY STEP 2.....	5
FIG. 3	ASSEMBLY STEP 3.....	5
FIG. 4A	ASSEMBLY STEP 4.....	5
FIG. 4B	ASSEMBLY STEP 4 (CLOSE-UP VIEW OF HANDRAIL).....	6
FIG. 5	ASSEMBLY STEP 4 (MULTI-SECTION MODELS).....	6
FIG. 6	LABEL PLACEMENT DIAGRAM.....	9

SAFETY PRINCIPLES

Each stair system conforms to the generalized specifications disclosed in this manual and fulfills our demanding standards for quality, safety and durability.

Vestil Manufacturing Corp. recognizes the critical importance of workplace safety. Each person who **might** participate in the use or maintenance of the product must read this manual **and fully understand the directions BEFORE using or performing maintenance on the stairs. If you do not understand an instruction, contact Vestil for clarification. Failure to adhere to the directions in this manual might cause people, who assemble and/or use the stairs, to sustain serious personal injury or even to be killed.**

Vestil is **not liable** for any injury or property damage that occurs as a consequence of failing to apply either: 1) the instructions that appear in this manual; or 2) the information provided on labels affixed to the product. Furthermore, failure to exercise good judgment and common sense may result in property damage, serious personal injury or death. Such failure is solely the fault of the person(s) who acted without good judgment; it is **not another responsibility of Vestil**.

This manual uses SIGNAL WORDS to classify personal injury risks or situations that might lead to property damage, as well as to draw attention to safety message(s). The reader must understand that each signal word indicates the seriousness of the described hazard.

DANGER Identifies a hazardous situation which, if not avoided, WILL result in DEATH or SERIOUS INJURY. Use of this signal word is limited to the most extreme situations.

WARNING Identifies a hazardous situation which, if not avoided, COULD result in DEATH or SERIOUS INJURY.

CAUTION Indicates a hazardous situation which, if not avoided, COULD result in MINOR or MODERATE injury.

NOTICE Identifies practices likely to result in product/property damage, such as operation that might damage the stairs.

PRODUCT DESCRIPTION



Thank you for purchasing a Modular Stairway ("stairs") made by Vestil Manufacturing Corporation ("Vestil"). Our stairs are rigorously engineered to produce durable, high-quality products. Although stairs are common, simple products, all personnel must familiarize themselves with the installation and maintenance instructions provided in this manual.

Vestil stair systems are constructed from steel and are protected by a powder coat finish. We design stair systems for modularity to facilitate shipping and simple assembly. At least 2 persons should work together to assemble the stairs. A fork truck and/or crane might be required to raise and position the assembled stair system for connection to the upper level.

Specifications of each standard model appear in the tables below:

Model	Maximum Rated Load
STAIR-5 to -22	1000 lbs. (~454kg)

Options	
HKIT-1	3/4" Masonry Drill Bit
HKIT-4	Qty: 4, 3/4" x 4" Long Anchor Bolts

Model	Number of Steps	Landing Height in inches	Net Weight in Pounds	Model	Number of Steps	Landing Height in inches	Net Weight in Pounds
STAIR-5	5	35	227	STAIR-14	14	96	604
STAIR-6	6	42	302	STAIR-15	15	102	614
STAIR-7	7	49	312	STAIR-16	16	108	680
STAIR-8	8	56	377	STAIR-17	17	114	690
STAIR-9	9	63	387	STAIR-18	18	120	755
STAIR-10	10	70	453	STAIR-19	19	126	765
STAIR-11	11	77	463	STAIR-20	20	132	831
STAIR-12	12	84	529	STAIR-21	21	138	841
STAIR-13	13	90	539	STAIR-22	22	144	906

Vestil Manufacturing Corp. created this manual to acquaint owners and operators of our prefabricated stair systems with safe operation and maintenance procedures. **Employers are responsible for instructing employees to use the product properly (see OSHA standard 1910.24 accessible at http://www.osha.gov/pls/oshaweb/owadisp.show_document?p_table=STANDARDS&p_id=9716). Employees and any other person, who might assemble, use, or perform maintenance on the stairs, must read and understand every instruction BEFORE assembling, using, or performing maintenance on the stairs.** Contact Vestil for answers to any question that remain after reading the entire manual.

Although Vestil diligently strives to identify foreseeable, hazardous situations, this manual cannot address every conceivable danger. The end-user is ultimately responsible for exercising sound judgment at all times.

Exploded Parts Diagram & Parts List

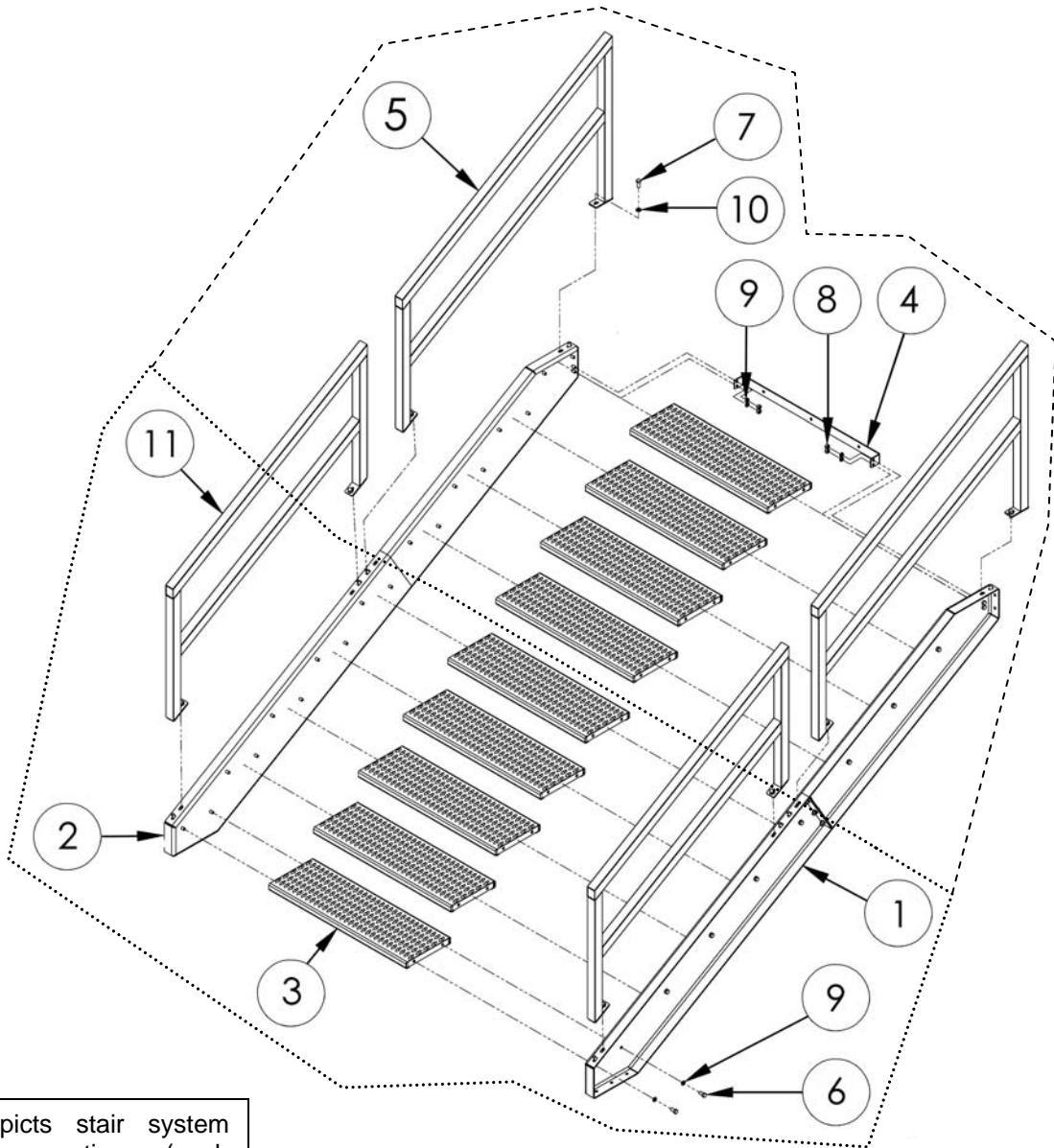

Drawing depicts stair system with 2 step sections (each section enclosed by dashed lines).

Parts List

ITEM NO.	DESCRIPTION	QTY.
1	ASSEMBLY, SIDERAIL, RIGHT	1
2	ASSEMBLY, SIDERAIL, LEFT	1
3	WELDMENT, STEP	5 to 21
4	BRACKET, WALL MOUNT	1
5	WELDMENT, HANDRAIL, TOP	2
6	1/2"-13 x 1"LG HHCS Z PLATED GRADE 5	20 to 84
7	1/2"-13 x 1 1/4"LG HHCS Z PLATED GRADE 5	8 to 24
8	1/2 - 13 UNC GR. 5 HEX NUT	8 to 16
9	LOCK WASHER, Ø 1/2	28 to 108
10	Ø1/2 USS FLAT WASHER PLAIN	12 to 36
STAIR-10 THRU 21 ONLY BELOW, IN ADDITION TO ABOVE		
11	WELDMENT, HANDRAIL, BOTTOM	2 or 4

HARDWARE

(ACTUAL SIZE)

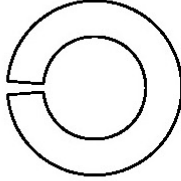
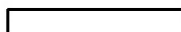
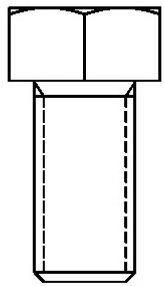
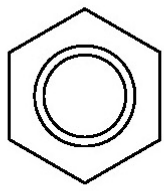
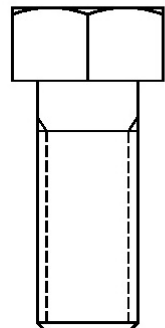
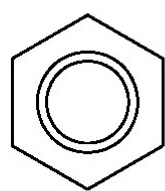
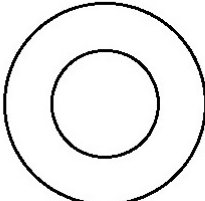
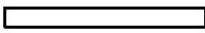
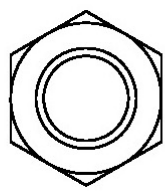
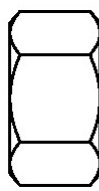
  <p>ITEM # 9 1/2" LOCK WASHER</p>	  <p>ITEM # 6 1/2-13 X 1"</p>	  <p>ITEM # 7 1/2-13 X 1 1/4"</p>
  <p>ITEM # 10 1/2" FLAT WASHER</p>	  <p>ITEM # 8 1/2-13 UNC GR. 5 HEX NUT</p>	

WARNING Improper assembly or installation may result in serious personal injuries. **Read the entire manual before assembling and installing the stair system.** If questions remain after you finish reading the manual, contact Vestil for answers.

- DO NOT use the stair system to store items, materials, etc.
- DO NOT place weight that exceeds the maximum rated load (capacity) of a step on one or more steps.

ASSEMBLY INSTRUCTIONS

Tools required: combination of 3/4" socket wrench and/or 3/4" crescent wrench

NOTE: The numbers in parentheses correspond to item numbers from the "Parts List" on p. 3. Stair system components are heavy; at least 2 people should work together to assemble the stairs.

STEP 1 — Place step assembly on ground with handrail slots facing up as shown below in Fig. 1. Notice that each siderail has an inside (flat) and outside (concave) surface. The flanges on the side rails must face away from one another.

Multi-section units (refer to Figures 1B & 6): fasten siderails together using fasteners (7, 8 & 9). Orient siderails correctly (see Fig. 6 on p. 6) before bolting them together.

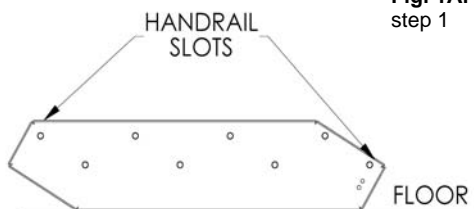

Fig. 1A: Assembly step 1

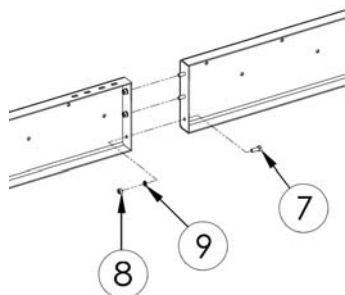

Fig. 1B: Assembly step 1 [additional connections required for multi-section models]

STEP 3 As shown in Fig. 4, connect the wall mount bracket (#4) to the side rails with bolts (#6), lock washers.

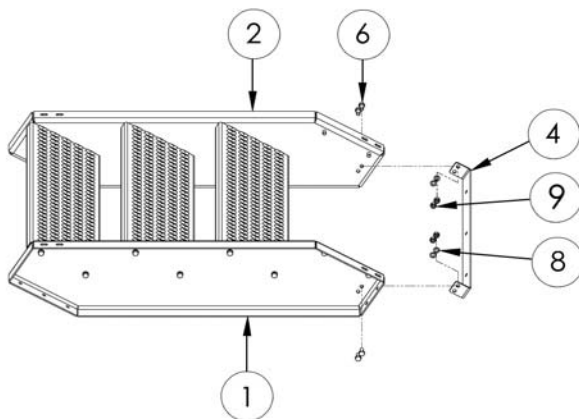

Fig. 3: Assembly step 3
[NOTE: Top step not shown]

STEP 2 As shown in Fig. 3, fasten the steps (#3) to the side rails (#1 & 2) with bolts and washers (#6 & 9). To simplify assembly, loosely fasten the top and bottom steps to the siderails, followed by the middle steps. Orient steps with the grip struts on top. After loosely fastening each step, fully tighten the connections.

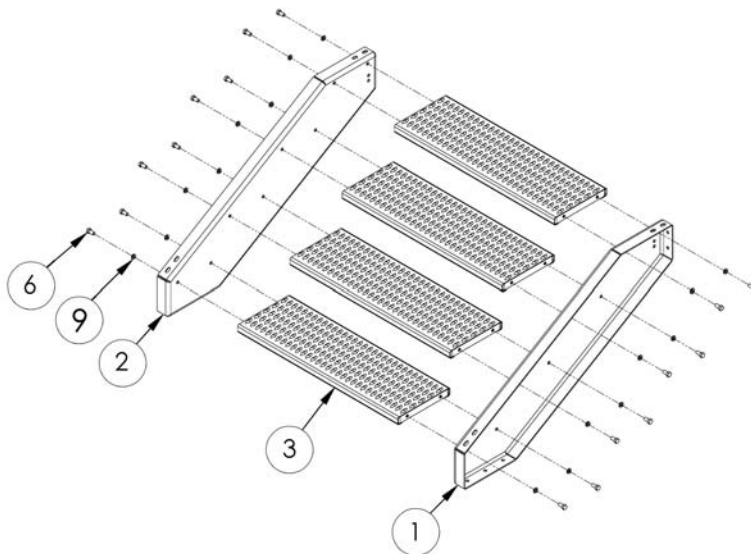

Fig. 2: Assembly Step 2

STEP 4 Attach handrails. As shown in Fig. 5, each handrail fastens to a siderail at 4 points.

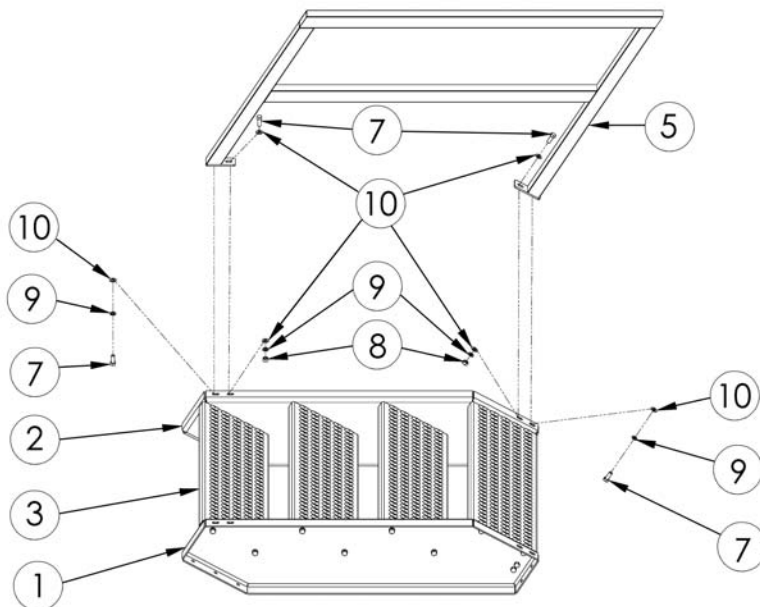

Fig. 4A: Assembly step 4

Step 4 (continued from p. 5): Attach handrails according to the diagram below.

Inner connections: put a washer (10) on a bolt (7), insert the bolt through the handrail bracket, then secure the connection with another washer (10) followed by a lock washer (9) and a hex nut (8).

Outer connections: put a lock washer (9), then a washer (10) on a bolt; then insert the bolt up through the outer handrail slot into the base of the handrail.

Complete all 4 connections for each handrail; then tighten all fasteners.

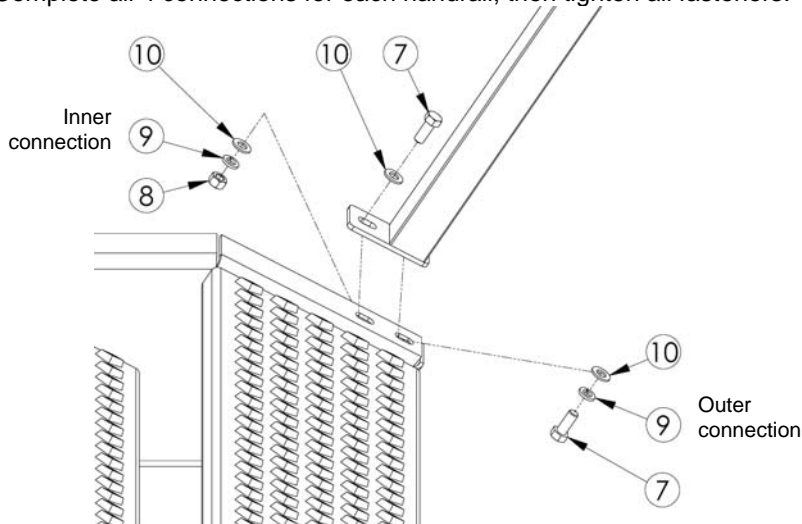
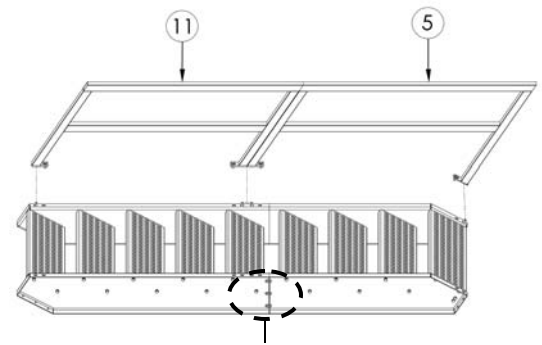

Fig. 4B: Close-up view of handrail fasteners

Step 5: Assembly [multi-section units]

Two types of handrails will be used (Fig. 6). One type mounts to the top of the unit (Item #5), and the other mounts to the bottom (Item #11). Make sure handrails are butted tight together before tightening down all of the fasteners.



Close-up of junction shown in Fig. 1B

Fig. 5: Assembly step 4 [multi-section units]

INSTALLATION INSTRUCTIONS

Installation requires a lifting device (fork truck or crane). Not using a lifting device may result in serious personal injury or damage to the unit causing it to be defective. When mounting the unit to the wall, the anchor locations must be in a structurally sustainable location.

Measurements & Wall and Floor Markings:

1. Find the center of the doorframe and mark the wall with a vertical line from base of the doorframe to the floor. In the diagram below, A identifies the point where the line intersects the floor. Measure up the line from point A a distance equal to "Top step height" on your approval drawing and mark that point on the line. This point is shown as D in the diagram below.
2. Measure a distance you select (for instance, 4 feet) on both sides of point A along the base of the wall. Mark those points (B and C in diagram below).
3. Mark the floor with a line from A to E. The distance from A to E must equal the "OVERALL LENGTH" on your approval drawing. The lengths of lines BD and CD should be equal. Similarly, BE and CE must be equal.

NOTE: Measurements assume square angles between wall and floor, and do not account for likely variations in the surfaces of the wall and floor.

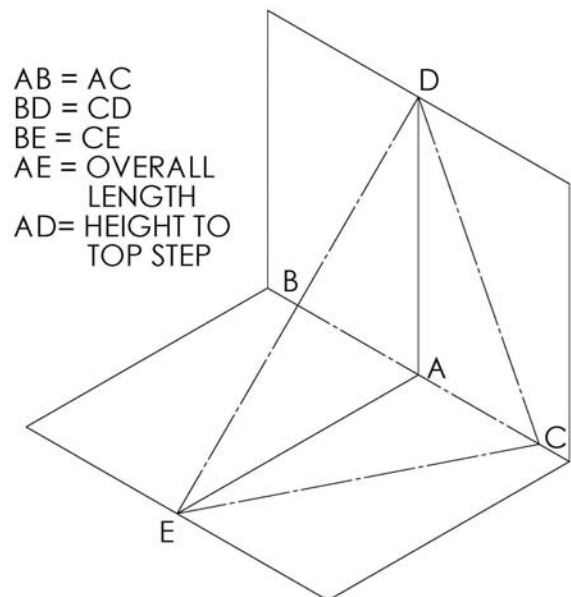
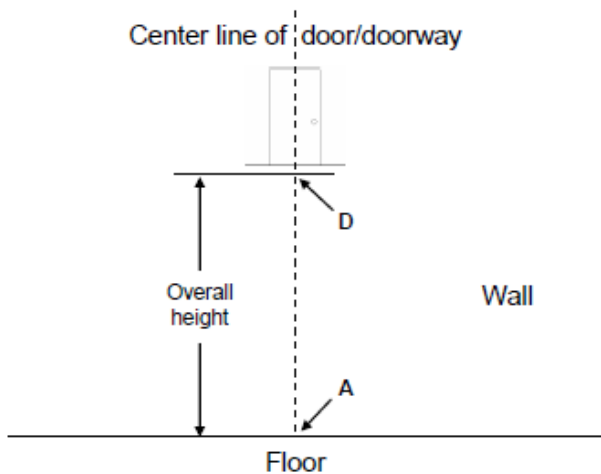

Prepare floor:

1. Mark the floor 19-1/4 inches from, and parallel to, line AE on each side of line AE. The parallel lines are depicted below as dashed lines.
2. Mark the points on the parallel lines an "OVERALL LENGTH" distance from the wall (---line in diagram below).
3. Mark the points on both parallel lines 2", 6" and 10" from the Overall Length line (intersections of ---- and).
4. Drill six holes sized appropriately for 3/4" concrete anchor bolts

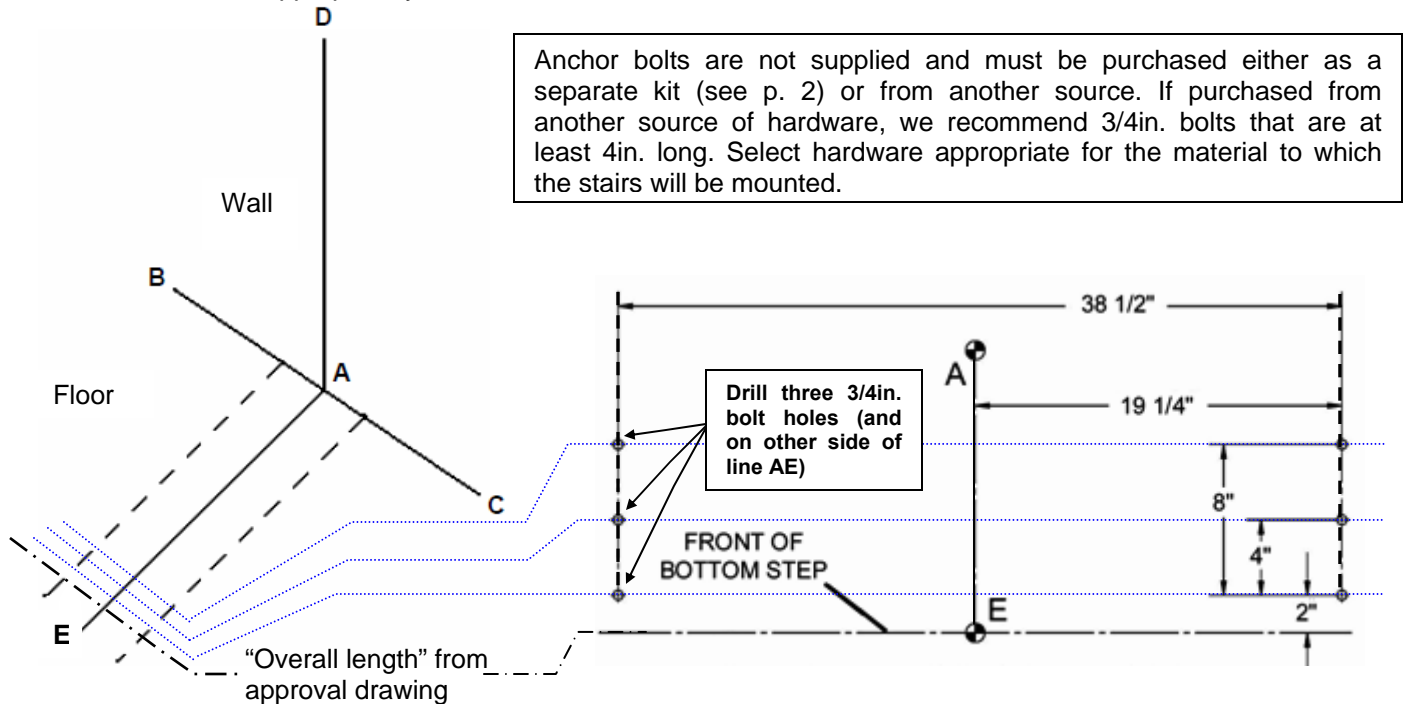

Prepare wall:

1. Mark a level line (shown as ---) that extends 20in. on both sides of point D.
2. Mark the points 19 1/2 in. from D on the level line on both sides; then draw lines parallel to AD. Parallel lines only need to be ~7 – 8 inches long. Mark the points on both parallel lines (intersections of --- and) 2in. and 5in. below the level line. These points correspond to bolt hole locations.
3. Mark the point 4 in. below the level line on line AD (point is intersection of A—D and ---). Mark the point on each 12 1/2 in. parallel line 4 in. below the level line (intersections of --- and).
4. Drill the seven holes for 3/4" anchor bolts

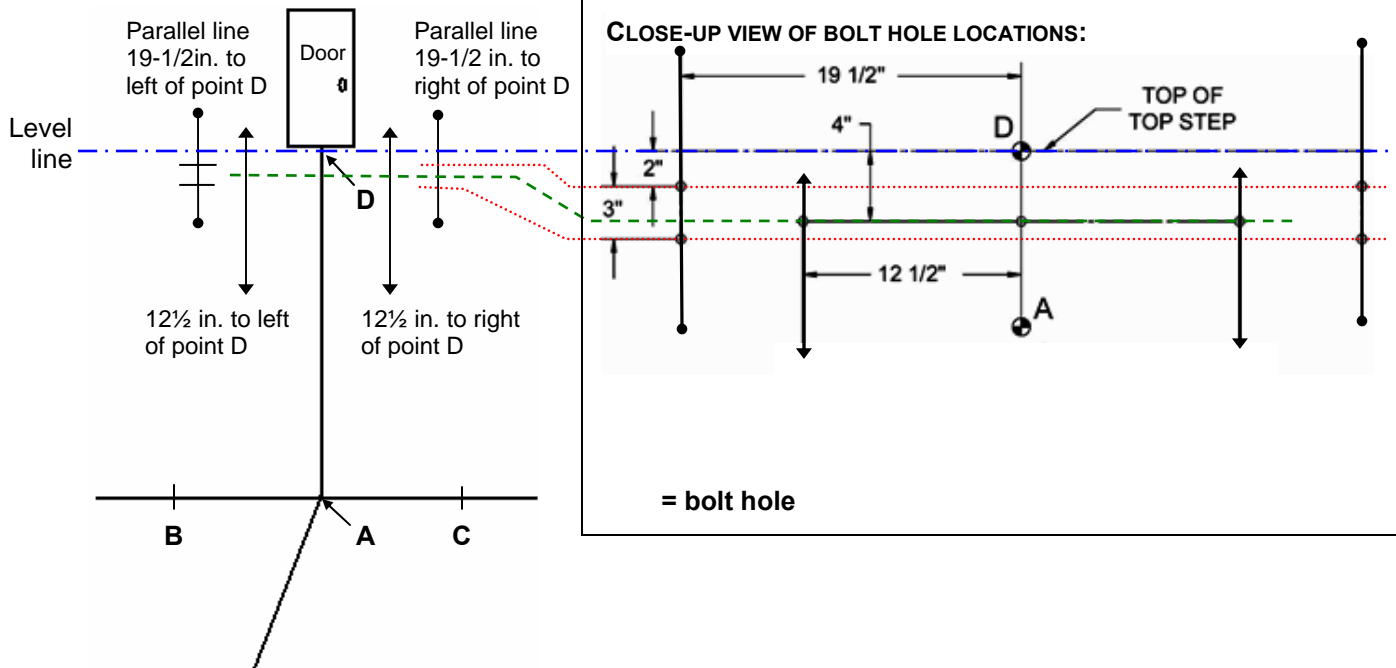

MAINTENANCE AND INSPECTIONS

The purchaser of this stair system bears all responsibility for compliance with regulation(s), code(s) including local building code(s), and standard(s) that constitute requirements by law in the location where the device is *used*.

Inspections:

⚠WARNING DO NOT use the unit if an inspection reveals any structural damage. Structural damage might include, but is not limited to, cracked welds, warping or other deformation of the steps, handrails, or siderails.

Regular/Frequent: The person(s) designated to conduct inspections **by your employer/the owner** must do so **before the unit is used for the first time**. If the unit is infrequently used, inspect the stairs *at least* once every 4 weeks for:

1. Loose steps and handrails.
2. Loose fasteners.
3. Debris on steps and handrails that might make the steps slippery, cause corrosion, lead to rust formation.

Periodic: inspect the following at least once every 6 months for damage due to corrosion or rusting, excessive wear, cracking, or warping:

1. Siderails
2. Handrails
3. Concrete around the stair system mounting hardware
4. Fasteners (bolts, nuts, etc.)

Maintenance:

⚠WARNING The owner/your employer must implement a maintenance program to ensure the proper function and safety of the unit, and is responsible for training employees to work on the unit. "Work on" refers to operating, loading, cleaning, servicing, maintaining, or repairing the unit. **ONLY** trained, competent maintenance personnel or contractors should perform inspection, maintenance, or repair work.

The reader should understand the significant difference between performing necessary adjustments and repairs, and work that modifies the stairs:

➤ "Adjustment" refers to a simple correction that restores the unit to normal operating condition. Examples of adjustments include tightening loose fasteners and removing dirt or other debris from the surface; "repair" refers to replacing worn parts with new replacement parts. Neither adjustment or repair alters the stairs from its original condition.

DO NOT use the stairs if adjustments or repairs are incomplete! Return the unit to service ONLY after finishing all necessary repairs and adjustments.

➤ A modification is a permanent alteration of the stair system from its original condition. Examples of modifications include bending the siderails or handrails and removing part(s). **NEVER modify the stairs without first receiving express, written approval from Vestil. Modifications may render the stairs unsafe to use.** If Vestil approves a modification in writing, you are responsible for labeling the equipment with the following information:

1. Name of the person(s) and or company who performed the modifications;
2. Date modification(s) performed;
3. Description of modification(s).

Step 1 Tag the unit, "Out of Service."

Step 2 Conduct "Regular/Frequent" and "Periodic" inspections.

Step 3 If deformity, corrosion, rusting, or excessive wear of structural members is present, DO NOT use the stairway. Contact Vestil for instructions.

Step 4 Perform necessary adjustments and/or repairs.

Step 5 Contact Vestil for directions if a condition(s) is discovered during an inspection that is/are not addressed in this manual.

Step 6 Make a dated record of the repairs, adjustments and/or replacements made.

Markings

Contact Vestil for replacement labels.

Fig. 6: Label placement diagram

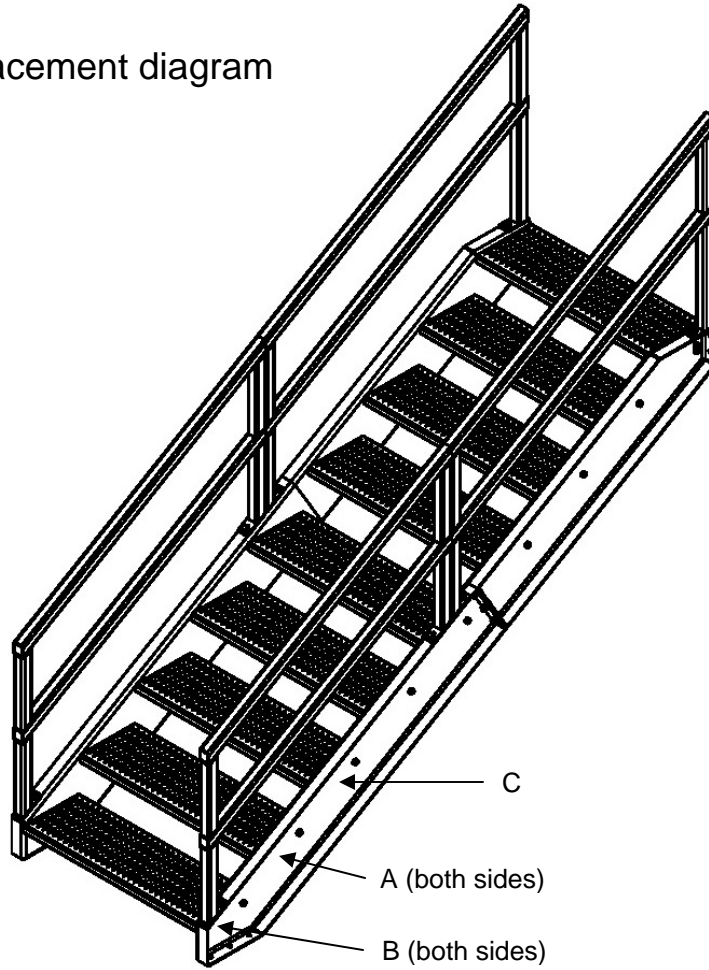

A: Vestil Logo



B: Label #203-2



C: Label #287

MODEL/MODÉLO/MODÈLE _____
CAPACITY _____ lbs.
CAPACIDAD/CAPACITÉ _____ kgs.
SERIAL/SERIE/SÉRIE _____
VESTIL MANUFACTURING CORPORATION
sales@vestil.com * www.vestil.com
2017 REV 02/03